



U.S. Diving  
**Safety  
Training  
Manual**

Second Edition



UNITED STATES DIVING, INC.

# U.S. DIVING SAFETY TRAINING MANUAL Second Edition

*Safety Training for Competitive Diving Coaches:  
Risk Management, Injury Control, Emergency Response  
and Care of Competitive Diving Injuries*



**JANET L. GABRIEL, M.A.**

**Senior Editor and Project Director**

*U.S. Diving Director of Education, Safety and Development*

U.S. Diving, Inc.

Pan American Plaza

201 S. Capitol Ave., Suite 430

Indianapolis, Indiana 46225

**DONALD E. LEAS, M.S.**

**Associate Editor, Project Consultant**

*Co-Chairman, U.S. Diving Safety Committee*

Associate Professor Emeritus

Clarion University of Pennsylvania

Clarion, PA

**GERALD S. GEORGE, Ph.D.**

**Associate Editor, Project Consultant**

*Co-Chairman, U.S. Diving Safety Committee*

Professor of Health and Physical Education

University of Southwestern Louisiana

Lafayette, Louisiana

U.S. Diving Publications

Indianapolis, Indiana



United States Diving, Inc.  
Pan American Plaza  
201 South Capitol Avenue, Suite 430  
Indianapolis, Indiana 46225

**Executive Director:**

**Todd B. Smith**

**Executive Board of Directors:**

William Walker ..... President,  
Camila McLean ..... Vice President, Administration  
Dave Burgering ..... Vice President, Senior Diving  
Joe Chirico ..... Vice President, Junior Olympic  
Jim Stillson ..... Vice President, Olympic International  
Cokey Smith-Huffman ..... Treasurer  
Jim Hocking ..... Diving Rules Chairman  
Thomas Gompf ..... FINA-TDC Representative  
Chuck Knesel ..... Law and Legislation Chairwoman  
JohnDeininger ..... Masters Chairman  
Russ Bertram ..... At-Large Member  
Michele Mitchell-Rocha ..... At-Large Member  
Keith Russell ..... At-Large Member  
Rick Schavone ..... At-Large Member  
Tracy Bonner ..... Athlete Representative  
Kevin McMahan ..... Athlete Representative  
Becky Ruehl ..... Athlete Representative  
Abel Sanchez ..... Athlete Representative  
Steve McFarland ..... Immediate Past President  
Clyde Truttman ..... Allied Representative, YMCA  
Dave Ardrey ..... PDCA Representative

2nd Edition printing, December 1999  
Copyright © 1999-U.S. Diving Publications  
All Rights Reserved  
Printed in the United States of America

*Matthew Leone, Colgate University*  
*Seth Pederson, U.S. Diving Director of Communications*

**Copy Editors**

*David J. Shatkowski*

**Book Layout Design Consultant**

*Irene Johnston, Business Manager*

**Publication Distribution**

**Cover Design:**

*Seth Pederson*

**Cover photo of Mark Ruiz:**

*Ken Redmond*

**Illustrator:**

*James H. Stephenson*  
Stephenson Art and Design  
3885 Yellowstone LN. N  
Plymouth, MN 55446

## ACKNOWLEDGMENTS

Much deserved appreciation for the efforts of the many who contributed to the development of this text. Special thanks to those whose input provided shape and direction:

**Kenneth S. Clarke, Ph.D.** for developing and maintaining the U.S. Diving Injury Surveillance database since its inception in 1990. The injury profile from the database provided a starting point for this text.

**U.S. Diving coaches and athletes** who have supported U.S. Diving's injury data collection effort and taken the time to report athletes' injuries, regardless of whether or not insurance claims have been filed.

**Gerald E. DeMers, Ph.D.** for developing Section III: Emergency Response and Care of Competitive Diving Injuries in its entirety and for all his expertise and effort that went into the development of the *Safety Training for Competitive Diving Coaches* instructor and course materials.

**Mike Saltzstein**, U.S. Swimming Western Zone Director, and **Tracy Bonner**, U.S. Diving Athlete Representative, for attending the U.S. Diving Board of Governors session at the 1998 USAS Convention and reminding diving coaches that our athletes need, expect and deserve our emergency preparedness to respond appropriately in an aquatic environment.

**William A. Sands, Ph.D.** for his unique blend of insights on physical readiness that come from the integration of the coach's and sport scientist's point of view and for his willingness to share his technical expertise to advance the sport.

**Cindy Slater**, USOC library resources, for providing sources and information all along the way.

**Preston Levi**, Research Services and **Rita Levi**, Information Services, The Henning Library and FINA Archive, International Swimming Hall of Fame, Fort Lauderdale, FL for their assistance in providing updates on research and accessing information sources and to **Laurie Marchwinski**, ISHOF Art Director, for designing the cover of the *Safety Training for Competitive Diving Coaches* Instructor's Manual.

**David Mair**, USOC Associate Director, Risk Insurance Management, for developing the USOC Risk Management Workshops that advocate safety training for coaches as a risk management tool.

**Tom Crawford**, USOC Coaching Director, **Audrius Barzdukas**, Associate Director, and **Jan Schnittger**, Manager, for their leadership in coach education administration.

**Ron O'Brien, Ph.D.**, U.S. Diving National Technical Director, for contributing his time, expertise and guidance in support of the development of this text.

**Robert M. Malina, Ph.D.**, Professor and Director, Institute for the Study of Youth Sports, Michigan State University, for his dedication and service to children and athletes worldwide and for extending his leadership and resources in support of our NGB's safety effort.

**Gerald S. George, Ph.D.** for developing an NGB safety certification model in 1985, spearheading U.S. Diving's safety certification program in 1989, and providing the guidance, continuity and support necessary to sustain this ten-year effort.

**Don Leas, M.S.** for his persistence in applying his considerable expertise to work through all the difficult technical problems related to the development of this text.

# U.S. DIVING SAFETY MANUAL

## Second Edition

### CONTRIBUTING AUTHORS

#### **Hobie Billingsley, M.S.**

U.S. Olympic Coach 1968, 1972  
Coached: 3 Olympic Gold medal winners  
3 Olympic Bronze medal winners  
4 Pan American Gold Medalists  
FINA World Cup champion on 1-m, 1989  
115 National Diving Champions  
23 Big Ten Champions  
U.S. Olympic Judge- Olympic Games, 1996  
Read the Olympic Oath at Opening Ceremonies-1996  
Organized: World Diving Coaches Association, 1967  
American Diving Coaches Association, 1970  
National Women's Chairman 1970-1973  
American Swim Coaches Assoc. Coach of the Year 1964-1970  
First Recipient of the NCAA Coach of the Year Award  
International Swimming Hall of Fame  
Mike Malone Award 1973; Fred Cady Award 1974  
National Collegiate & Scholastic Swimming Trophy  
Head Diving Coach, Indiana University 1959-1989  
P.O. Box 482  
Bloomington, IN 47402

#### **Michael S. Brown, M.S.**

A.B. Dartmouth College; M.S. Indiana University  
1971 U.S. National A.A.U. Champion, 1-m  
Coached: four U.S. Olympians; 18 International Olympians  
12 NCAA Championship Teams, 2 AIAW Championship Teams  
U.S. National Team Coach: Olympic Games, World Championships,  
World University Games, Goodwill Games and FINA World Cup  
4969 Cordova Bay Road, Victoria, B.C. V8Y 2K1

#### **Dan Copeland**

Former National Sales Manager, AMF-American  
Former Regional Sales Manager  
AAI- American Athletic, Inc.  
Jefferson, Iowa 50129

#### **Gerald E. DeMers, Ph.D.**

Aquatic Safety and Risk Management Specialist  
Former Diving Coach, University of Oregon  
University of Utah, 1973-1980  
Member: YMCA of the USA  
Progressive Swimming Revisions Committee, 1999  
Lifeguard Training Revisions Committee, 1995  
American Red Cross  
Lifeguard Training Revisions Committee, 1995  
Progressive Swimming Revisions Committee, 1992  
Department Chair, Professor  
Physical Education and Kinesiology Department  
California Polytechnic State University  
San Luis Obispo, CA 93407

#### **Herb Flewwelling**

Inventor of the Bubble Machine  
Industrial research scientist, Domtar Ltd., 1966 - 1976  
Canadian Team Coach: 1988 Olympic Games  
Coached Finalist in:  
1987 Pan American Games, 1987 World University Games  
1988 Olympic Games, 1989 World Cup  
1990 Commonwealth Games, 1991 World Championships  
Coached  
12 Canadian Open National Championship Titles  
7 River Heights Drive N.W.  
Edmonton, Alberta T6M 2R1

#### **Janet L. Gabriel, M.A.**

B.S. Indiana University Physical Education specializing in Elementary PE  
M.A. University of Texas-Physical Education  
Physical Educ. teacher 1-12, The Hockaday School, Dallas, TX 1974-76  
Head Age Group Diving Coach, 1977-1986  
Texas Swimming Center, Austin, TX  
Texas Age Group Diving Coach of the Year-1986  
Fort Lauderdale Dive Team Dive Safe coach 1995-1998  
Senior Editor, *U.S. Diving Safety Manual* 1990  
Editor, *Diving Safety, A Position Paper*-1988, 1992  
Senior Editor, *Dive Safe*-1995  
Assoc. Editor, U.S. Diving Sport Science Seminar Proceedings 1993, 1995  
U.S. Diving Director of Education, Safety and Development  
International Swimming Hall of Fame  
One Hall of Fame Dr., Fort Lauderdale, FL 33316

#### **Frank W. Gruber, M.D.**

Former Chief of Emergency Medicine  
Chesapeake General Hospital; Chesapeake, Virginia  
Former Medical Director  
Now-Care Medical Center, Chesapeake, Virginia  
Worked with elite divers 1982-1991 to help them develop correct body  
alignment techniques  
Worked with U.S. Diving 1991- present in the Advanced Behavioral  
Modeling project to assist elite divers in developing competition  
strategies for better meet performances

#### **D. Joe Hunsaker, B.S.**

B.S. City Planning University of Illinois  
Chairman, Counsilman/Hunsaker & Associates  
Natatorium Planners and Design Consultants  
Design Engineers for the 1996 Olympic Games swimming pools  
Projects include over:  
27 international class competition and training centers  
42 colleges, 60 highs schools, 78 municipal, county, military sites  
27 leisure and water park pools, 27 fitness and wellness centers  
22 corporation and institution facilities

#### **Robert Ketrick, M.S.**

B.S. Electrical Engineering; M.S. Computer Engineering  
Head Diving Coach-Northern Virginia Dive Club  
Reston, VA 20191-2950

**Dick Kimball, M.A.**

Former two-time NCAA Diving Champion, 1957  
World Professional Diving Champion, 1963  
U.S. Olympic Diving Team Coach, 1964, 1980, 1984, 1988, 1992  
Olympic Diving Team Coach (foreign team) 1996  
Coached: 4 Olympic Gold Medalists  
Pan American Games U.S. Diving Team Coach, 1983  
U.S. World Championships Diving Team Coach, 1973, 1978, 1986  
World University Games U.S. Diving Team Coach, 1985  
1987-88 NCAA Women's coach of the year  
Three-time Big Ten Coach of the Year  
Fred Cady Memorial Award recipient, 1974  
International Swimming Hall of Fame  
Michigan Hall of Honor  
Rochester, Minnesota Hall of Fame  
National Collegiate & Scholastic Swimming Trophy  
Diving Coach, The University of Michigan  
1000 South State Street  
Ann Arbor, Michigan 48109

**Micki King, Colonel, US Air Force (Ret)**

1972 Olympic Springboard Gold Medalist  
1968 Olympic Diving Team member, 4th place 3-m  
10 U.S. National Championship titles  
1988 Olympic Diving Team Leader  
1996 Olympic Team Leader  
Commissioner, President Ford's Commission to Study Olympic Sports  
which resulted in Amateur Athletic Act of 1978  
Charter Chairperson, USOC's Athlete Advisory Council  
International Swimming Hall of Fame  
Women's Sports Foundation Hall of Fame  
U.S. Olympic Hall of Fame  
First— (and only woman to date) to coach an NCAA champion  
in ANY sport  
U.S. Air Force Academy Assistant Athletic Director (1983-1989)  
U.S. Air Force Academy Men's and Women's Diving Coach  
1973-1977; 1983-1989  
NCAA Coach of the Year, 1987, 1988, 1989  
University of Kentucky Assistant Athletic Director  
Memorial Coliseum  
Lexington, Kentucky 40506-0019

**Gregory M. Lederer, Esq.**

Simmons, Perrine, Albright & Ellwood, P. L. C.  
115 3rd Street S.E., Suite 1200  
Cedar Rapids, Iowa 52401

**Greg Louganis**

1976 Olympic silver medalist, 10 m  
1984, 1988 Olympic double gold medalist  
Five-time World Champion  
Pan American Games double gold medalist, 1979, 1983, 1987  
Winner of 47 U.S. national diving championship titles  
National Sports Festival double gold medalist 1982-1987  
Three-time NCAA Champion  
1987 FINA World Cup gold medalist, 3 m  
Winner: James E. Sullivan Award, '84; Jesse Owens Award, '87  
International Hall of Fame, 1985  
Olympic Hall of Fame, 1985

**Ron O'Brien, Ph.D.**

Former Ohio State NCAA 1m Champion; AAU 3m Champion  
U.S. Olympic Diving Team Coach, 1972, 1976, 1980, 1984, 1988,  
1992, 1996  
U.S. Olympic Diving Team Assistant Coach and Manager, 1968  
Pan Am Games U.S. Diving Coach, 1967, '75, '87, '91; manager, 1983  
U.S. World Championship Diving Team Coach, 1975, 1978, 1982, 1986,  
1991, 1994  
FINA World Cup U.S. Diving Team Coach, 1981, 1983, 1985, 1987,  
1989, 1993, 1995  
Coached: 5 Olympic gold medalists, 3 silver, 4 bronze  
8 World Champions  
14 Pan American Gold Medalists  
5 FINA World Cup gold medalists  
87 U.S. National Team Champions  
134 U.S. Individual National Champions  
14-time recipient of the Mike Peppe Award  
International Swimming Hall of Fame  
Ohio State University Sports Hall of Fame  
Pennsylvania sports Hall of Fame  
National Technical Director, United States Diving

**Benjamin D. Rubin, M.D.**

Co-Chairman, U.S. Diving Sports Medicine Committee  
Assistant Clinical Professor  
Department of Orthopedic Surgery  
University of California, Irvine  
Team Physician: U.S. Diving; Mission Viejo Nadadores  
Member: American Academy of Orthopaedic Surgeons  
American Orthopaedic Society for Sports Medicine  
International Society of Arthroscopy, Knee Surgery, and  
Orthopaedic Sports Medicine  
Orthopaedics and Sports Medicine of Orange County  
302 W. LaVeta Ave., Suite 202  
Orange, CA 92866

**Ray Rude**

Employed by Lockheed Aircraft Co., 1936-1946  
tooling engineer; tooling for aircraft production  
President, Productioneering, 1947-65; specialized tooling on  
machine aircraft parts for major U.S. aircraft manufacturers  
including tooling for aircraft wing panels, structural fittings  
President, Arcadia Air Products, 1950-1980; produced aircraft  
tooling until 1965 and Duraflex diving boards  
President, Duraflex International Corp.  
Tracy Clark Station  
Sparks, Nevada 89434

**John Salvo, M.S.**

A.B., M.S., Physical Education, Syracuse University  
Former Head Coach, Men's Gymnastics, Princeton  
Former National Sales Manager  
Speith-Anderson U.S.A. Inc.  
Milltown, New Jersey 08850

**William H. Walker, Esq.**

Attorney at Law  
Member: The Florida Bar, St. Petersburg Bar Assn.  
U.S. Diving: Life Member  
President, 1998 -  
Vice President, Junior Olympics, 1982-1986  
Vice President, Senior Diving, 1986-1990  
Vice President, Administration, 1994-1998  
Member and chair, U.S. Diving Foundation  
U.S. Nationally Certified Diving Judge, 1983  
FINA Judge, U. S. Diving National Team Leader  
Law Office of William H. Walker, Chartered  
501 First Avenue North, Suite 403  
St. Petersburg, Florida 33701

## U.S. DIVING SAFETY MANUAL REVIEW PANEL

**Steven J. Anderson, M.D.**

*Co-Chairman, U.S. Diving Sports Medicine Committee*  
*Clinical Professor*  
Department of Pediatrics  
University of Washington  
*Chairman, Committee on Sports Medicine & Fitness*  
American Academy of Pediatrics  
3216 NE 45th Place, Suite 304  
Seattle, WA 98105

**Hobie Billingsley, M.S.**

*U.S. Olympic Coach 1968, 1972*  
*Head Diving Coach, Indiana University 1959-1989*  
P.O. Box 482  
Bloomington, IN 47402

**Michael A. Clark, Ph.D.**

*Assistant Professor, Institute for the Study of Youth Sports*  
Dept of Kinesiology  
213 I.M. Sports Circle  
Michigan State University  
East Lansing, MI 48824-1049

**Kenneth S. Clarke, Ph.D.**

*Senior VP-Risk Analysis*  
*SLE Worldwide, Inc.*  
27751 Calle Rabano  
Sun City, CA 92585

**Randall W. Dick**

*Senior Director of Sports Sciences*  
*National Collegiate Athletic Association*  
*Committee on Competitive Safeguards &*  
*Medical Aspects of Sports*  
6201 College Boulevard  
Overland Park, KS 66211-2422

**William L. Farrar, Jr., P.C.**

*Attorney at Law*  
8409 Dorsey Circle, Suite 201  
Manassas, Virginia 20110-8305

**Tim Flannery**

*Assistant Director*  
*National Federation of State High School Associations*  
11724 NW Plaza Circle  
Kansas City, MO 64153-1158

**Samuel James Freas, Ed.D.**

*President/CEO, International Swimming Hall of Fame*  
One Hall of Fame Dr.  
Ft. Lauderdale, FL 33316

**Rita Glassman**

*Associate Executive Director*  
*National Youth Sports Safety Foundation, Inc.*  
333 Longwood Avenue, Suite 202  
Boston, MA 02115

**Gerald S. George, Ph.D.**

*Co-Chairman, U.S. Diving Safety Committee*  
Professor of Health and Physical Education  
University of Southwestern Louisiana  
Lafayette, Louisiana 70504

**Ralph L. Johnson, Ph.D.**

*Chairman, Sport Management Department*  
North Greenville College  
Senior Consultant, P.A.C.I.  
6 Grove Park Court  
Taylors, South Carolina 29687

**Irene Johnston**

*Business Manager*  
U.S. Diving  
Pan American Plaza  
201 South Capitol Ave., Suite 430  
Indianapolis, IN 46225

**Richard Kimball, M.A.**

*U.S. Diving, Chair-Education Committee*  
Diving Coach  
University of Michigan  
1000 South State St.  
Ann Arbor, MI 48109

**Donald E. Leas, M.S.**

*Co-Chairman, U.S. Diving Safety Committee*  
12200 E. St. Rt 69, #377  
Dewey, AZ 86327

**Matthew Leone**

*Diving Coach/Director, First Year and Summer Programs*  
Colgate University  
Hamilton, NY 13346

**Robert M. Malina, Ph.D.**

*Professor and Director, Institute for the Study of Youth Sports  
Editor-in-Chief, American Journal of Human Biology*  
Department of Kinesiology  
213 IM Sports Circle  
Michigan State University  
East Lansing, MI 48824-1049

**Stu Marvin**

*Facility Manager, Hall of Fame Aquatic Complex*  
501 Seabreeze Blvd.  
Fort Lauderdale, FL 33316

**Camila C. McLean, Architect, AIA**

*Vice President, Administration-U.S. Diving*  
PO Box 2041  
Moultrie, GA 31776

**Megan Neyer, Ph.D., LPC**

*Total Performance Systems*  
2944 Lavista Way  
Decatur, GA 30033

**Ron O'Brien, Ph.D.**

*National Technical Director, U.S. Diving*  
P.O. Box 784  
Islamorada, FL 33036

**Seth Pederson**

*Director of Communications*  
U.S. Diving  
Pan American Plaza  
201 S. Capitol Ave., Suite 430  
Indianapolis, IN 46225

**Cynthia A. Potter, M.A.**

*Diving Coach*  
The Westminster Schools  
Box 1043443  
Ashford Dunwoody Rd.  
Atlanta, GA 30319

**Benjamin D. Rubin, M.D.**

*Co-Chairman, U.S. Diving Sports Medicine Committee*  
Sports Medicine, Arthroscopic Surgery, Orthopaedic Surgery  
302 W. La Veta Ave., Ste. 202  
Orange, CA 92866

**William A. Sands, Ph.D.**

*Associate Professor, Dept of Exercise & Sport Science*  
300 S. 1850 E  
University of Utah  
Salt Lake City, UT 84112-0920

**Laura J. Slane**

*Associate Director-Aquatics  
Membership and Program Development*  
YMCA of the USA  
101 North Wacker Dr.  
Chicago, IL 60606-7386

**Kim W. Tyson, M.S.**

*Aquatic Coordinator*  
Department of Kinesiology and Health Education  
College of Education  
The University of Texas at Austin  
Austin, TX 78712

**William H. Walker, Esq.**

*President, U.S. Diving*  
Law Office of William H. Walker, Chartered  
501 First Avenue N., Suite 403  
St. Petersburg, FL 33701

**John Wingfield**

*Coach, U.S. Diving Regional Training Center*  
IUPUI Natatorium  
901 W. New York St.  
Indianapolis, IN 46202

## FOREWORD

The purpose of this safety manual is to: (1) enhance the safety awareness of coaches, participants, and others associated with the sport; and (2) reduce the risk of injury by providing advice from knowledgeable and experienced professionals related to the responsibilities of diving coaches. The scope of this text is risk management, injury control, emergency response and care of competitive diving injuries. The material in this manual may be adapted to meet the individual needs of each diving facility. The section standards and chapter competencies listed are minimum expectations. Coaches must strive to be proficient. Coaches must use their special role with athletes, parents and others responsibly.

The U.S. Diving Safety Manual (Second Edition) serves as the text for the *Safety Training for Competitive Diving Coaches Course*. This course is not intended to be a lifeguard training course. Requirements to pass this course include:

- 1) pass a written exam (*80% or higher*) on the responsibilities of coaches and
- 2) pass practical care skills.

Two care options are available to participants:

**Option A-(in water)** demonstrate deep water rescue and spinal injury management

**Option B-(on deck)** deck assist rescue and spinal injury management (within their physical limitations).

Coaches are advised that state, and in some cases county and even city regulations may determine rescue and spinal injury management procedures within their governance. Coaches should discuss these procedures with their employers, facility managers and/or EMS providers to determine the emergency action plan followed locally.

U.S. Diving is the national governing body for competitive diving in the United States. Coaches must be current in Safety Training for Competitive Diving Coaches, first aid and CPR before applying for U.S. Diving coach membership. Although this manual targets the U.S. Diving club coach, it is also meant to be accessed by the entire diving community. From the facility manager to meet officials, summer instructors, high school and college coaches to national team coaches, there is information appropriate for your level of expertise. Safety awareness can only be achieved when individuals with different responsibilities--be they coaches, administrators, lifeguards, doctors, parents or athletes- come together in a concerted effort.

## DEFINITIONS

**Safety awareness** is an attitude or condition that promotes reasonable and prudent actions and behaviors relative to safety measures in diving.

**Coach** is a teacher/instructor trained in diving pedagogy who teaches/supervises a competitive diving program. In this manual the coach is considered a trained sports professional regardless of whether coaching is his/her primary occupation.

**Diver** is a participant/athlete/performer in a competitive diving program.

**Competitive diving** is a sport involving head- and feet-first entries from 1 and 3 meter springboards or 5, 7.5 and 10 meter platforms, whereby a diver performs a list of dives according to the rules and regulations of a national and/or international governing body.

# Contents

<b>PREFACE: A PHILOSOPHY OF SAFETY AWARENESS .....</b>	<b>xiii</b>
by Hobie Billingsley, M.S.	
<b>SECTION I: RISK MANAGEMENT FOR DIVING COACHES .....</b>	<b>1</b>
<b>Chapter I. Legal Responsibilities .....</b>	<b>3</b>
1. Legal Responsibilities of the Diving Coach .....	3
by Gregory M. Lederer, Esq.	
2. Responsibilities of Officials .....	11
by William H. Walker, Esq.	
<b>Chapter II. Documentation Responsibilities.....</b>	<b>15</b>
by William H. Walker, Esq.	
<b>SECTION II: INJURY CONTROL FOR DIVING COACHES .....</b>	<b>35</b>
<b>Chapter III. Planning Responsibilities .....</b>	<b>37</b>
1. Emergency Plans .....	38
by Frank W. Gruber, M.D. and Gerald E. DeMers, Ph.D.	
2. Practice Plans .....	45
by Janet L. Gabriel, M.A.	
<b>Chapter IV. Competitive Diving Facilities .....</b>	<b>53</b>
by D. Joe Hunsaker, B.S.	
<b>Chapter V. Competitive Diving Equipment.....</b>	<b>61</b>
1. Competitive Springboards: Duraflex .....	62
by Ray Rude	
2. In Ground Sparging Systems .....	67
by Herb Flewwelling	
3. Above Ground Sparging Systems .....	70
by Robert Ketrick, M.S.	
4. Spas and Hot Tubs .....	72
by Gerald E. DeMers, Ph.D.	
5. Gymnastics Mats in Diving Programs .....	75
by Dan Copeland	
6. Use of Portable Landing Pits for Dryland Diving Training .....	79
by John F. Salvo, M.S.	
7. Diving Training Stations and Spotting Rigs for Trampoline, Dry board, Dry Platform and Wet board .....	81
by Dick Kimball, M.A.	
8. Spotting Belts .....	89
by Dick Kimball, M.A.	

<b>Chapter VI. Supervision Responsibilities .....</b>	<b>91</b>
by Janet L. Gabriel, M.A.	
<b>Chapter VII. Proper Instruction .....</b>	<b>99</b>
1. Using Skill Progressions in Diving .....	100
by Ron O'Brien, Ph.D.	
2. Safety Spotting .....	103
by Dick Kimball, M.A.	
3. Overhead Mounted Belt Spotting Techniques .....	108
by Dick Kimball, M.A.	
4. Landing and Entry .....	111
by Greg Louganis	
5. Body Awareness and Spatial Orientation .....	118
by Micki King	
<b>Chapter VIII. Know Diver's Skills and Limitations .....</b>	<b>123</b>
1. Orthopedic Care .....	124
by Benjamin D. Rubin, M.D.	
2. Physical Readiness .....	127
by Michael S. Brown, M.S.	
3. Injury Management .....	137
by Gerald E. DeMers, Ph.D.	
<b>SECTION III. EMERGENCY RESPONSE AND CARE OF COMPETITIVE DIVING INJURIES .....</b>	<b>141</b>
<b>Chapter IX. Emergency Response .....</b>	<b>143</b>
by Gerald E. DeMers, Ph.D.	
1. Responding to Diving Related Emergencies .....	144
2. Rescue Techniques for Injured Divers .....	147
3. Spinal Injury Management .....	160
<b>Chapter X. First Aid Care for Injuries Specific to Competitive Diving .....</b>	<b>177</b>
by Gerald E. DeMers, Ph.D.	
1. Life Threatening Emergencies .....	178
2. Non-LifeThreatening Emergencies .....	185
3. Health and Disease Transmission .....	192
<b>INDEX .....</b>	<b>203</b>

## **PREFACE: A PHILOSOPHY OF SAFETY AWARENESS**

by Hobie Billingsley, M.S.

### **Competitive diving in the United States has an excellent safety record**

The sport of competitive diving was introduced into the United States from England in 1900. U.S. Diving, the National Collegiate Athletic Association (NCAA) and the National Federation of State High School Associations (NFSHA) report no record of fatalities or catastrophic injuries in competitive diving.

### **FINA dimension influence on safety**

U.S. Diving, the national governing body of competitive diving, recommends adherence to the competitive diving facility dimensions of the Federation International de Natation Amateur (FINA). These dimensions, cited for their influence on safety in a study conducted for the U.S. Consumer Product Safety Commission in 1977, were revised in 1991 and have continued to provide competitive divers with adequate room to maneuver above and below the water surface.

FINA rules state that all World Championships (except Masters World Championships) and Olympic Games must be held in a pool which complies to specified FINA rules. It is not unusual that a facility built prior to the publication of the facility dimension guidelines should not meet all of the presently published guidelines. What makes any conforming or nonconforming facility safe is how it is used. If a facility's deficiency does not materially interfere with a competition, or if practice, conducted in a controlled environment, is monitored so that the use of the facility does not increase the possibility of a collision in flight or in the water, facilities may be used by competitive divers provided appropriate risk management strategies are followed.

### **The coach's safety philosophy is focused on creating positive motivational climates for divers**

Coaching objectives of the safety-conscious coach should include creating a positive, supportive and safe motivational climate for divers by:

- respecting their rights,
- involving them in the decision-making process and
- providing them a rationale for why a dive worked.

The role of the coach is to teach and challenge, enforce and advocate. Coaches should fully appreciate the diver's talents, abilities and limitations. No amount of training will ever reach beyond the diver's talent or capabilities. In order to fully realize the diver's potential, the coach should reinforce effort and persistence. Coaches should avoid behaviors that take away the diver's dignity. No diver should be forced by the coach to perform a dive. A diver who has "bounced" on the entry, experiencing great pain, should not be forced to get back up and immediately repeat the dive. Instead, the coach should allow for recovery, retrace the skill progression and put the diver back in the safety belts, if available. Coaches should realize that not all divers can or will perform every dive. The challenge for the coach and diver is to work together to find the "window of opportunity" in which the diver is comfortable to attempt a new dive or repeat a dive that resulted in an improper, painful entry or injury.

### **The will to win determines the will to prepare**

Divers should take responsibility for their preparation by maintaining constant vigilance with respect to conditioning and rehabilitation efforts, by following proper progression during skill acquisition and by following the rules. Divers should not attempt to execute new or difficult dives without proper instruction and preparation or against the advice of the coach. Divers should maintain control of their bounce or jump height when performing multiple bounce drills. Due to the nature of the risks and fears involved in diving, it is the coach, not the diver, who ultimately must have the authority to make the final decision regarding performer readiness for diving skills. Coaches and divers should establish in advance that intent to perform, once readiness is achieved, is a responsibility of the diver. Nothing can be learned or accomplished without the willingness of the diver to try. The desire to win will determine what price the diver will offer in terms of preparing physically and mentally for the competition.



# SECTION I: RISK MANAGEMENT FOR DIVING COACHES

## SECTION STANDARDS

### Upon completion of this section, coaches should know:

•*The scope of legal responsibilities that comes with assuming a coaching position, i.e. warning of inherent risks, proper planning, providing a safe physical environment, providing proper equipment, supervision, proper instruction, knowing your divers' skills and limitations, maintaining current competencies, keeping records and providing proper first aid and emergency care.*

•*To provide coaching assistants, divers and parents/guardians with education about injury control, injury reporting and sources of medical care.*

•*To properly inform coaching assistants, parent/guardians and athletes of the inherent risks associated with diving so that decisions about participation can be made with informed consent.*

•*To convey the need for and availability of appropriate medical insurance.*

•*To facilitate injury control by recognizing and insisting on safe playing conditions.*

•*To understand and enforce the rules and regulations of appropriate bodies that govern sport and education.*

•*To participate in continuing education regarding rules' changes, improvements in equipment, philosophical changes, and technical developments in order to enhance the safety and success of the diver.*

•*To demonstrate organizational and administrative efficiency in implementing diving programs, e.g. facility maintenance.*

•*To facilitate a unified medical program of injury control, care and management of injuries by coordinating the roles and actions of the coach and a NATA certified athletic trainer, if available, with those of the physician.*

•*To demonstrate skill in injury control, recognition and evaluation of injuries and the ability to assist divers with the recovery/rehabilitation from injuries that are generally associated with participation in athletics in accordance with guidelines provided by qualified medical personnel.*

•*To subscribe to a philosophy that acknowledges the role of athletics in developing the complete person (see Preface).*

**PLEASE NOTE:** *The standards and competencies marked by a bullet (•) at the beginning of each chapter are adapted for competitive diving from the National Standards for Athletic Coaches published by the National Association for Sport and Physical Education (1995). Competencies marked by an asterisk (\*) are covered by U.S. Diving in addition to the NASPE guidelines.*





# CHAPTER I LEGAL RESPONSIBILITIES

## Part 1. Legal Responsibilities of the Diving Coach

by Gregory M. Lederer, Esq.

### CHAPTER COMPETENCIES

**Upon completion of this chapter, coaches should be able to:**

#### Part 1

- *Know the legal responsibilities of the coach in transportation and communication and how to meet them.*
- *Know the specific risks to divers and how to reduce these risks.*
- *Inform those involved about the risks of diving by instructing divers and others concerned about the purpose of agreements to participate and the need for informed consent.*
- *Prior to participation, require the completion of all necessary agreements and medical forms by athletes and guardians.*
- *Discuss the importance of adequate health and accident insurance coverage with divers and parents/guardians prior to participation and at other times as needed.*
- *Organize and maintain appropriate records as evidence, in accordance with established administrative procedures and based upon relevant requirements, in the event of legal challenges.*

#### Part 2

- *Know and apply the rules and policies related to the safety and welfare of divers during all practices and competition.*
- *Know the rules and regulations of relevant governing bodies concerning participation in diving.*
- *Strictly enforce the rules of the governing body especially as they relate to the diver's eligibility to participate.*
- *Inspect facilities and equipment for potential safety hazards prior to each use.*
- *Manage key elements of contests, including inspecting and approving facilities.*
- *Enlist qualified individuals to be present to referee and judge all competitions.*
- *Attend rules meetings offered by appropriate sanctioning groups in order to be informed of rules changes and interpretations.*

Competitive diving, like any other athletic endeavor, routinely subjects the body to traumatic forces. It involves, therefore, a risk of bodily injury.

Although competitive diving carries a low risk of catastrophic injury compared to other competitive sports, the risk is always present. Injuries less serious, but still significant in terms of disability, pain and expense, occur in competitive diving with roughly the same regularity as in other “non-contact” sports. Recreational swimmers who dive, whether in pools or in natural bodies of water, experience a higher risk of catastrophic injury than competitive divers, principally from diving in shallow water.

If you instruct or coach diving, you must accept the responsibility to protect the diver from an unreasonable risk of injury. The key word in that sentence is “unreasonable.” The law recognizes that no amount of care and precaution will eliminate all risk of injury from diving or any other athletic activity. The training requirements, the frequency of error in the learning process, and the difficulty of providing a “dry” learning environment while the diver masters a new skill, make it impossible to immunize every diver from all risk of injury. Further, presuming that a coach can prevent all injury may be an invitation to disaster, since such an attitude relieves the diver of his/her own sense of responsibility for safety, which is so essential to minimizing the risks associated with diving. Safe diving, like good diving, is a product of hard work, skill, training and dedication on the part of the coach, the diver and all others who contribute to the sport.

When a diving accident occurs, the most immediate concerns are seen in terms of the diver’s pain, disability and medical care. After the initial shock, however, the diver, parents and others often start to think in terms of assessing fault and seeking reimbursement of expenses and compensation for injury. These issues become particularly acute when the diver does not have adequate health insurance to pay his/her medical bills. Often, in the face of mounting medical bills, or for a number of other reasons, the diver or his/her family will seek legal assistance. This becomes the first step to a lawsuit.

One may choose to engage in a philosophical or political debate about the American judicial system, its inequities, and its defects. While such conversations may be interesting, they are, in this context, not particularly relevant to the resolution of a particular claim. No matter what the initial motivation may be for bringing a claim, such claims are the reality of our system of resolving disputes. American justice seeks to provide fair compensation to those who are injured by the unreasonable conduct of others.

Coaches understandably are concerned. Those who dedicate their working or free hours (or both) to teaching or coaching, or to supervising youth and adults, are often unable to afford the price of litigation, either in the potential consequence of paying a court-ordered judgment or settlement, or the emotional turmoil, or the legal costs of defending a lawsuit, regardless of merit.

Adequate insurance, if available, can do much to lessen the consequences to a coach of a claim or lawsuit. Insurance

is no substitute, however, for a vigorous program of safety awareness that reduces the risk of injury as well as the exposure of the sports professional to civil liability.

It is understandable and appropriate that coaches want to know not only how to make diving safer for the diver, but also how to protect themselves from the adverse consequences of litigation. The primary purpose of this manual is to reduce the risk of injury. This introductory chapter also will provide the coach with an understanding of the legal aspects of diving safety.

## TORTS

The American judicial system provides a civil-damage remedy for those injured due to the fault of another. Civil damages usually take the form of money as compensation for injury.

Courts define fault by reference to the legal concept of negligence. **Negligence is conduct that falls below the standard of care that society expects of a reasonably prudent person acting under similar circumstances.** If a person does something that we would expect the normal, rational and prudent individual, acting under similar circumstances with appropriate regard for the safety of others, *not* to do, that person has acted in a negligent manner. Conversely, if we would expect that same reasonable person *to do* something under those circumstances, the failure to act in that fashion constitutes negligence.

If a person is injured and if he/she believes the injury was caused by the unreasonable conduct of another, he/she can make a claim against the person or entity that he/she believes to be at fault. Statistics establish that the vast majority of claims are resolved at this early stage, by negotiated settlement. If settlement does not occur, the injured person may file a lawsuit. Once a person files a lawsuit and serves the defendant with notice of the suit, the defendant must appear and defend.

## ELEMENTS OF PLAINTIFF’S TORT CASE

It is the plaintiff’s burden to prove his/her allegations. In virtually all jurisdictions, the plaintiff must prove those allegations by a “preponderance” of the evidence. Preponderance means the greater weight of the evidence or the more convincing evidence.

Most jurisdictions require proof of four elements in a tort case: (1) duty, (2) breach of duty, (3) proximate cause, and (4) damages.

### Duty

**The plaintiff must establish that the defendant owed the plaintiff a duty of care. Duty is a legal obligation to act in accord with a standard of conduct designed to protect persons like the plaintiff from an unreasonable risk of harm.** For example, a motorist owes a duty to another

motorist to obey the rules of the road. Those rules were created to eliminate unreasonable risks of injury to the traveling public.

The court, rather than the jury, determines the existence and extent of a duty. The judge determines whether the defendant owed a duty of care to the plaintiff and defines the standard of conduct imposed by the duty. The court requires the jury to accept that duty and to apply it to the evidence submitted at trial.

## **Breach of duty**

**The plaintiff must prove that the defendant breached the duty.** In other words, the plaintiff must prove that the defendant did something a reasonable person owing the duty would not do, or did something that same reasonable person would not do. In a lawsuit arising out of a motor vehicle accident, this issue can be relatively straightforward. The court will determine that the defendant owed another motorist a legal duty to stop at a stop sign, and to proceed only when the intersection is clear. The jury will determine from the evidence whether a reasonable driver would have proceeded forward when the plaintiff was approaching the intersection. If the jury decides that a reasonable driver would have waited until the plaintiff passed, then the defendant breached the duty by failing to yield to the plaintiff.

In a lawsuit arising out of a diving accident, the court likely will provide the jury with only a very general description of the standard of care owed by the coach or instructor to the diver. The jury will have considerable latitude in evaluating the coach's conduct.

## **Proximate Cause**

**The plaintiff next must prove that the coach's negligence must be, in legal terms, "a proximate cause" of the injury and damages.** The meaning of the term "proximate cause" varies from state to state. Some courts use a "but for" test: The defendant's negligence is a proximate cause if the accident would not have occurred "but for" the negligence. Other courts also use a "substantial factor" test: The negligence is a proximate cause if it was a "substantial factor" in bringing about the accident. Most courts use both tests in combination to assure a real and significant connection between the negligence and the accident, and to eliminate as a cause an event that is remote or coincidental.

## **Damages**

**If a plaintiff has established a duty and has proved breach of duty and proximate cause, the plaintiff must then prove that he/she has suffered damages.** In the typical personal-injury cases, courts permit the plaintiff to recover damages for the medical bills, for lost earnings, and other consequential, out-of-pocket expenses. The court also usually permits the plaintiff to recover damages for any disability and pain and suffering. Most of these items of damage have two components: the damages incurred through the trial, and those that will be incurred in the future. The plaintiff must

prove that he/she actually incurred (or will incur) the particular item of damage and the amount, in order for the jury to award the damages. Some items of damage – pain and suffering is a good example – are not susceptible to any exact mathematical calculation. In those circumstances, the judicial system affords the jury great latitude in agreeing on an appropriate amount.

## **TORT DEFENSES**

A defendant has several defenses that can be asserted in a tort action, and most of them can have some application to a diving case. Again, these defenses vary from state to state.

The principal defense available to a defendant is simply the denial of the plaintiff's allegations. Remember, it is the plaintiff who has the burden to prove the allegations of duty, negligence, proximate cause and damages. A coach can defend simply by denying that he/she was negligent and by contesting the evidence and testimony on that issue. The defendant also can deny the allegations of proximate cause and damage and argue that any alleged negligence was not a cause of the accident. Denying the allegation is not a passive act. The defendant can offer evidence and testimony to support the denial. In general, this contest between the plaintiff's allegations and the defendant's denial is the focus of much of the trial of any tort action.

The law also recognizes several "affirmative defenses" that would be available to a diving professional. An affirmative defense is a special defense that, because it involves an affirmative allegation by the defendant, requires the defendant to assume the burden of proof on that defense. Just like the plaintiff, a defendant who asserts an affirmative defense has the burden to prove the defense's allegations. These affirmative defenses and their elements vary from state to state.

## **Contributory negligence**

Common sense tells us that there may be many causes of an accident, that more than one person or entity may be at fault. The law recognizes this reality, and permits the defendant to prove that the injured plaintiff caused or at least contributed to his or her own calamity. Historically, the law has referred to this concept as "contributory negligence." As with negligence, the defendant must prove that the plaintiff did not behave as would a reasonable person under similar circumstances. The defendant also must prove that the plaintiff's negligence was a "proximate cause" of the accident.

Of course, the defendant first must establish the existence of a duty. When the plaintiff is an adult, the law readily imposes a duty to act with regard to one's own safety. When the plaintiff is not an adult, application of the duty is not automatic. Some states refuse to impose the duty on young children. Other states apply it gradually or in stages, depending on the age of the plaintiff. Most states now impose the duty but instruct the jury to measure the minor's conduct by a reasonable person of the plaintiff's age, education and experience.

For many years, American law provided that contributory negligence was an absolute defense to a tort action. If the plaintiff was at all negligent in a manner that was a proximate cause of the accident, he or she could not recover at all. Courts and legal commentators criticized this rule as overly punitive, unfair and illogical. Judicial observers also concluded that, in practice, juries usually overlooked the lesser mistakes of an injured plaintiff and found liability against a negligent defendant, especially when the injury was serious. Although some states retain contributory negligence, most have abandoned it in favor of comparative negligence.

### **Comparative negligence**

Most states now provide that a negligent plaintiff's recovery is reduced in proportion to his/her negligence as compared with all the causal negligence. In other words, the jury first determines who was negligent and then allocates the fault – in percentages totaling 100% – against each such party. The court then reduces the damage award proportionately. For example, a plaintiff against whom the jury allocates 25 percent of the fault will recover only 75 percent of his/her damages.

In theory at least, a plaintiff who receives 99% of the fault will still recover 1% of the damages. Courts term this “pure comparative fault.” Many “comparative fault” states have adopted a 50% cut off; a plaintiff who is found to be 51 percent negligent or more cannot recover at all. Courts term this “modified comparative fault.”

Comparative fault may be more equitable, but these calculations and the resulting strategies can become fairly complex, especially in cases involving multiple defendants. An example may be helpful. Suppose that an injured diver sued his coach, the owner of the pool where the accident occurred, and the manufacturer of the diving board. Suppose the manufacturer added the local installer of the board as a defendant. Each of the defendants blamed each other and the plaintiff for the accident. After trial, the jury found that each party was at fault and allocated the fault as follows:

plaintiff	20
coach	40
pool owner	05
manufacturer	25
installer	10

Suppose that the jury then determined the damages to be \$100,000. The court would reduce plaintiff's recovery to \$80,000. Who would pay, and how much? The answers to those questions vary greatly, from state to state. In some states, the plaintiff can pick from whom he or she recovers. In other words, the installer, who was less at fault than the plaintiff, could be faced with paying the entire judgment. This right to pick any defendant whom the jury finds at fault becomes critical when a defendant has no or insufficient insurance and assets. While law permits the installer to seek contribution from the other defendants for their proportionate share of the damages, the installer (and eventually other solvent defendants)

will pay for any defendant who cannot pay its share. This is called the principle of joint and several liability. It is a doctrine of long-standing in American jurisprudence, but it has been eroding in conjunction with the adoption of comparative negligence. Especially when the jury finds the plaintiff at fault, some states would require each defendant to pay only its percentage of the gross damages.

### **Assumption of risk**

**A sports professional frequently will defend against a tort action by claiming that the athlete “assumed the risk” of the injury that occurred.** In most states, this is not an affirmative defense in a strict legal sense. The professional has no obligation to prove fault on the part of the athlete. Instead, the professional submits that the accident was just that, an accident. Inherent in any athletic activity is the risk that bodily movement will result in trauma, simply because of the imperfections of human endeavor, the effects of gravity, and the fragility of the human body. Whether you leap to catch a pass or batted ball, slide into second, attempt a wrestling escape, hit a blistering serve, run by or around a 250-pound linebacker, or attempt a triple twisting somersault, you take the risk that you will perform the maneuver imperfectly and suffer injury. By voluntarily engaging in the activity, you assume the risk of the injury.

While most states do not classify assumption-of-risk as an affirmative defense, the diving coach must accept, as a practical matter, the obligation of persuading the jury of the following facts: (1) the accident was not the result of unreasonable behavior, (2) the accident was caused by the imperfections of human performance and the traumas imposed by athletic activity, and (3) the diver knew the unavoidable risks associated with the activity, and proceeded voluntarily to attempt the maneuver. An example may be helpful.

A competitive diver at the collegiate level wishes to incorporate a new dive, which is more difficult than the dive she is performing, into her routine. She discusses it with her coach, who approves the progression. In fact, the new dive is the next logical dive for this diver to learn, practice, master and perform in competition. The coach instructs properly, and the diver learns and practices the new skill just as the coach has instructed. Part of the coach's instruction was a discussion of – and a warning about – the particular risks associated with the new dive. The diver progresses to the point where both diver and coach are considering whether to incorporate the dive in the routine for the next competition. One day, after several successful executions of the dive, the diver missteps on the approach, takes off from the board at too vertical an angle, and strikes the board on the way down. She suffers an injury. The coach was not negligent. The diver made a mistake, but she was not negligent. This is assumption of risk.

It frequently is the challenge of the defense lawyer and the athletic professional in sports-injury litigation to convince the jury that an accident is just that, an accident, and not the result of negligent coaching. A young diver who has been seriously injured presents a very compelling picture to the jury, particularly if the diver and parents have not been warned of

the possible risks. Average citizens on juries are just like your non-diving friends. They know little about diving. And, like you, they are naturally sympathetic and want to do the right thing. It is perfectly natural to be motivated to compensate the injured. The juries may assume that the coach has the means, through insurance or otherwise, to pay. Juries are more inclined to find negligence and liability on the part of the defendant when the injury is serious and catastrophic.

## RISK MANAGEMENT FOR DIVING COACHES

The diving coach facilitates injury control by reducing the risk of accidents. You reduce the risk of accidents by exercising care throughout your diving program. You expend money to hire, supervise and retain competent personnel and to purchase and maintain quality equipment. You warn participants (and parents of minors) of the risk of injury. You teach and coach in a professional and structured manner, so that your divers encounter only those risks for which they and you have prepared.

One of the very first steps in developing a good injury control program is to continue reading this manual. What follows in this chapter is a list of the components of a good injury control – risk management – program for the diving coach or instructor (see Figure 1).

### Warning of inherent risks

The diving professional cannot rest with quality instruction and equipment. One may still be liable because the diver has not been warned of the dangers inherent in an activity unknown to the diver. Failure-to-warn has been the source of many athletic-injury lawsuits, and it is a troublesome issue for coaches and instructors. All sports involve an element of risk to the participant, and diving is no exception. It is important, however, for the professional to make the athlete (and the parent of a minor athlete) aware of this risk. In virtually every athletic-injury lawsuit, one of the plaintiff's claims is "failure to warn." In many cases it is the most important issue, and in some cases it eventually becomes the only issue. Courts initially saw this legal theory as part of the product-liability claims that plaintiffs asserted against manufacturers of equipment. More recently, plaintiffs have used "failure-to-warn" against athletic professionals as well.

What does "failure-to-warn" mean in competitive diving? The term stands for the allegation by the plaintiff that the coach (or manufacturer) failed to warn the diver of the risk of injury that existed in diving, either generally or with respect to a particular maneuver or skill. The typical scenario runs like this. The injured diver testifies, "I knew that diving was dangerous, and that I could get hurt. But I didn't know that I could break my neck and be paralyzed. I never thought about what would happen to me if I hit the board with my head while attempting that dive." Or, "I thought the water would protect me from serious injury." In either (or any other) version, the diver concludes by saying, "If I had known what

could happen to me, I never would have done that skill," or, "I would have been more careful," or, "I would have practiced in the belt longer."

Without regard to whether or not such testimony is truthful, the coach must be able to refute such testimony. One method is to demonstrate to the jury that the diver did, in fact, know the risk of injury. Another method is to prove that the coach warned the diver repeatedly of the risk of injury in language calculated to reach this particular diver, and in a manner calculated to affect the diver's behavior in terms of safety.

The first method is a matter for the defense lawyer and/or the expert witness, and it is a difficult task. Most experts recommend using both methods. Warn your athletes, and take steps to enable you to prove that you did so. **Use the warning in the U.S. Diving Waiver and Release of Liability Form (see Figure 1.2) which warns that the participant will be engaging in activities that involve risk of serious injury, including permanent disability and death.** Post the warning in the appropriate places in the pool area, locker room and coach's office.

Many conscientious coaches have expressed the need for caution, appropriate timing and sensitivity in communicating apocalyptic warnings to young athletes. These professionals appreciate the critical role that confidence plays in athletic execution. The coach has the right – indeed, the duty – to determine when and how such warnings should be given so that negative thought processes do not interfere with the development of the confidence necessary for learning and performing skills. The law must permit the professional to balance the duty to disclose the risk against the duty to instill confidence. The law also defers to the coach as the expert for determining time, place, format and content. The law also defers to the coach for customizing the message for the age and comprehension level of the athlete.

Nevertheless, you should follow these basic rules. You must communicate the warning message in clear and unequivocal terms. You must warn a diver of the risk of injury **before** the diver is exposed to that risk. You must communicate the warning to the parent as well as to the minor diver. You must explain the nature of the risk, the frequency of the risk and the extent of the risk. In diving, you should use language similar to the following:

*Diving, like all sports, carries a risk of physical injury. No matter how careful the diver and coach are, no matter how many spotters are used, no matter what height is used or what landing surface (including water) exists, the risk cannot be eliminated. Reduced, yes, but never eliminated. The risk of injury includes minor injuries such as bruises, and more serious injuries such as broken bones, dislocations and muscle pulls. But the risk also includes catastrophic injuries such as permanent paralysis or even death from landings or falls on the back, neck or head.*

# **RISK MANAGEMENT FOR DIVING COACHES**

## **LEGAL DUTIES**

- Warn of Inherent Risks**
- Keep Records**
- Plan Properly**
- Provide a Safe Physical Environment**
- Provide Proper Equipment**
- Provide Adequate Supervision**
- Provide Proper Instruction**
- Know Diver's Skills and Limitations**
- Provide Proper First Aid & Emergency Care**
- Maintain Current Competencies**

*Figure 1.1 Adapted from Risk Management For Coaches-Mair (1997) USOC Risk Management Workshop*

**U.S. Diving Amateur Athletic Waiver  
and Release of Liability**

In consideration of being allowed to participate in any way in United States Diving, Inc. athletics/sports programs, and related events and activities, the undersigned:

1. Agree that prior to participating, or in the case of a minor participant, the parent(s) or legal guardian(s) will instruct the minor participant that prior to participating, he or she should inspect the facilities and equipment to be used, and if the participant believes anything is unsafe, he or she should immediately advise his or her coach or supervisor of such condition(s) and refuse to participate.
2. Acknowledge and fully understand that each participant will be engaging in activities that involve risk of serious injury, including permanent disability and death, and severe social and economic losses that might result not only from their own actions, inactions or negligence but the actions, inactions or negligence of others, the rules of play, or the condition of the premises or of any equipment used. Further, that there may be other risks not known to us or not reasonably foreseeable at this time.
3. Assume all the foregoing risks and accept personal responsibility for the damages following such injury, permanent disability or death.
4. Release, waive, discharge and covenant not to sue United States Diving, Inc., its affiliated clubs, their respective administrators, directors, agents, coaches, and other employees of the organization, other participants, sponsoring agencies, sponsors, advertisers, and, if applicable, owners and lessors of premises used to conduct the event, all of which are hereinafter referred to as "releases," from any and all liability to each of the undersigned, his or her heirs and next of kin for any and all claims, demands, losses or damages on account of injury, including death or damage to property, caused or alleged to be caused in whole or in part by the negligence of the releasee or otherwise.

**I/WE HAVE READ THE ABOVE WAIVER AND RELEASE, UNDERSTAND THAT I/WE GIVE UP SUBSTANTIAL RIGHTS BY SIGNING IT AND SIGN IT VOLUNTARILY.**

\_\_\_\_\_/\_\_\_\_\_/\_\_\_\_\_  
ATHLETE (Signature) DATE

If athlete is less than 21 years of age and a resident of Colorado, Mississippi or Pennsylvania, or less than 19 years of age and a resident of Alabama, Nebraska or Wyoming, or less than 18 years of age and a resident of any other state, then the parent or legal guardian must also sign below.

\_\_\_\_\_/\_\_\_\_\_/\_\_\_\_\_  
PARENT OR LEGAL GUARDIAN (Signature/Relationship) DATE

\_\_\_\_\_  
PARENT OR LEGAL GUARDIAN (Printed Name)

*Figure 1.2 U.S. Diving Amateur Athletic Waiver and Release of Liability*

## Keep Records

Maintaining good files on your divers, your coaching, and your systems will make you a better coach and will help you prove that you are a good coach. Document your communication of warnings so that you can refute any claim that you did not warn. Document the progressions through which you have coached your diver so that you can demonstrate how careful you were in guiding your diver through the mastery of a difficult or risky maneuver.

## Plan Properly

Good teaching follows from thorough preparation. Be organized in your approach to coaching each of your divers. By planning the route you take the diver to the next progression, you reduce the role that chance, fatigue and emotion play in future decisions.

## Provide a Safe Physical Environment

Examine your facility. Is it safe? What can be done to make it safer? A safe environment has appropriate fire exits as well as enough water beneath the boards. It has an appropriate platform take-off surface that reduces the risk of slipping as well as good water quality. Don't permit your focus on the pool to obscure your view of the rest of the divers' environment.

## Provide Proper Equipment

Purchase quality equipment and maintain it properly.

## Provide Adequate Supervision

Regardless of the skill level, many divers are children or young adults. Many athletic injuries occur when children and young adults act immaturity. Without the discipline that quality adult supervision instills, young divers may resort to horseplay, daredevil stunts and sloppy performance. While a jury should find a diver injured during such behavior to be negligent, the same jury may also find the coach negligent, and perhaps more so, for creating an environment that permitted such behavior.

Make sure that your teacher-student ratio is appropriate for the skill level of the divers *and* of the coaches. Make sure that responsibilities being delegated to assistants are commensurate with their training and experience. Impose, announce and repeat all necessary safety rules, and then enforce them. The only thing worse than having no rules is imposing a rule and not enforcing it. Teach your students to take diving safety seriously.

## Provide Proper Instruction

Be organized in your approach to classes or practice sessions. Provide divers with individual instruction so you can account for their differences. Keep records of your activities and your divers' performances.

## Know your Diver's Skills and Limitations

Require that divers follow the appropriate (in *your* opinion, not the diver's) progressions in learning new dives. Do not push performance at the expense of safety or health.

## Provide Proper First Aid and Emergency Care

Know the emergency procedures for rescue, spinal injury management, first aid and CPR.

## Maintain Current Competencies

As a professional, you must acquire the knowledge necessary to coach, instruct or supervise at the level you intend to serve. Once you acquire that knowledge, you should maintain it through continuing education (formal or informal), so that you can keep pace with new developments in the sport. Make sure that your refresher courses include safety, not just the newest thoughts on compulsory dives.

## SUMMARY

No manual can be so detailed or inclusive that it can substitute for the exercise of common sense and professional judgment by a competent and conscientious coach who demonstrates a vigilant concern for safety in a particular diving environment. Use this chapter and its guidelines as a framework for fashioning and customizing your own safety program that meets the safety needs of your situation.

## REFERENCES

- Appenzeller H (1985) Legal responsibilities in gymnastics: An overview of legal responsibility. In George GS (ed.): USGF Gymnastics Safety Manual, Indianapolis, IN: The USGF Publications Department, pp. 7-13.
- Lederer G (1990) An overview of legal responsibilities. In Gabriel JL, George GS (eds.): U.S. Diving Safety Manual. Indianapolis, IN: U.S. Diving Publications, pp. 7-11.
- Mair D (1997) Risk Management for Coaches. In United States Olympic Committee Risk Management Workshop, Colorado Springs, CO: USOC

## Part 2. Responsibilities of Officials

by William H. Walker, Esq.

*(Note: The author gratefully acknowledges David A. Feigley and Neil J. Dougherty for their input into this chapter.)*

The preceding section identified the four elements of a lawsuit based on a claim of negligence – a duty owed the plaintiff by the defendant, a breach of that duty, an injury which results from the breach and damages to compensate the plaintiff for the loss, and considered those elements in the context of a coach's potential liability for injuries suffered by a diver. The same legal analysis applies to meet officials, but the unique nature of a meet official's relationship with the diver makes the analysis of his/her duty (and breach of that duty) significantly different than in the case of the coach.

### DUTY

Generally, meet officials owe participating divers an obligation to conduct the competition in a reasonably safe manner. If an individual agrees to be a meet official, he/she implicitly agrees to perform the requirements of the position with due regard for the safety of the divers. Likewise, most officials have certain authority, even discretionary authority, given to them by rules or tradition. With this authority comes the obligation to exercise the authority in a manner consistent with safety to the extent reasonably possible.

### BREACH OF DUTY

The question of whether an official has breached his/her duty to a diver by failing to act as a reasonable person would under the same or similar circumstances is judged, not simply by the standard of the person of ordinary prudence, but rather by the standard of a reasonably prudent official, i.e. a person who must, by the nature of his/her position, act in a specialized and skillful manner.

The technical rules of a sport are a primary source for determining the standard of care which an official must exercise. Accordingly, officials must be fully versed in the technical rules of diving which govern participation in meets.

Typically, the responsibility for officiating a diving competition is divided among a meet director, a meet or event referee and a number of judges. Often, an individual may act in one or more of these roles. In these instances, responsibilities may overlap. An official's duties may be delegated to others to perform. In delegation, however, the official must select competent people. While the actual assignments of specific duties may differ over time, or change from one type of meet to another, certain general duties of meet officials which may have safety implications merit consideration.

### DUTIES OF THE MEET DIRECTOR

The responsibilities of the meet director generally include: (1) securing an adequate facility for the competition; (2) determining the suitability of the equipment; (3) supervising the placement of equipment in regard to both safety and competition; (4) obtaining qualified officials to referee and judge the contests; (5) arranging for access to medical care in case of accident and injury; and, where applicable, (6) arranging for traffic flow control of stacked platform facilities. In most platform facilities in the United States, the 1 meter, 5 meter and 10 meter are stacked, as are the 3 meter and 7.5 meter. In many cases a diver on the 5 meter (or 1 meter) can safely dive simultaneously with a diver on the 7.5 meter (or 3 meter). Generally, divers on the lower platforms should cease diving when a diver on the 10 meter is cleared for take-off. However, not all stacked platforms allow for simultaneous diving. Traffic flow management should be utilized for the diver's safety in a given facility.

### DUTIES OF THE EVENT REFEREE

The referee may be responsible for: (1) enforcing the rules and regulations of the sanctioning body, including safety related rules such as halting the contest because of adverse weather conditions or allowing divers a restart without a penalty in the case of strong wind; (2) deciding on matters not covered directly by the rules; and (3) checking that all equipment continues to comply with applicable regulations as the competition progresses.

### DUTIES OF THE JUDGES

The acting judge is free of most administrative responsibilities, but should be alert to any obvious safety hazards and report them immediately to the referee. It is the practice in the United States for coaches to be assigned as event judges. Often a judging assignment is such that a judge/coach may also have a diver in the contest. In this case, and (especially at the junior level), the diver should be allowed access to his/her coach for consultation between the judging of dives.

### AREAS OF CONCERN

There are, in general, two major factors in diving accidents that may fall within the reasonable supervisory control of diving officials: (1) participant readiness; and (2) unsafe facilities/equipment.

### PARTICIPANT READINESS

The diver's coach (or in the absence of the coach the responsible team official) has the primary responsibility for

evaluating the appropriateness of the individual dives attempted during competition. Event officials may share this responsibility at least as to those matters which come to their attention during an event. **If an official has reason to believe that a diver is facing an unreasonable risk due to skill deficiency, fatigue, trauma or some other reason, he/she should notify the diver's coach or team manager and the event referee of his/her concern. In the case of junior competition, "The Meet Director or Meet Referee has the authority to eliminate any dive if, in his opinion, circumstances exist which might place the diver in any danger" (Rule 120.2.g).** The rules likewise provide methods for implementing this authority in ways which will not prejudice the diver's ability to remain in the contest (**Rules 107.5.b and 120.2.f**) – (see 1998 & 1999 United States Diving Rules and Regulations).

**Since decisions regarding the appropriateness of a particular dive or the readiness of a given diver are subjective judgments, it is recommended that those involved in making the decision take the time to consult with each other.** While such consultation may momentarily delay the meet, the increased likelihood of an accurate decision and the reduced effectiveness of subsequent complaints regarding alleged bias in the decision-making process will far outweigh the small amount of time lost. An overly conservative decision will almost certainly draw the wrath of coaches, divers and parents, while a judgmental error in the opposite direction may result in serious injury. Although meet officials have express authority over junior competitors, they defer to the individual opinions of the coaches and divers at the senior/masters and international levels.

## FACILITIES AND EQUIPMENT

**The meet director is usually the person primarily responsible for determining that the facility complies with the sanctioning requirements.** These duties can be performed personally or delegated to knowledgeable officials. The facility and equipment should be inspected before the first day of scheduled warm up periods; i.e., before competitors begin to use the facility and equipment.

Once it has been determined that the facility meets sanctioning requirements and the equipment is in good condition, **all officials and participants should be encouraged to immediately report any equipment failures.** Deficiencies should be corrected without delay, and any unsafe equipment should be closed until repaired. Any questionable equipment should be rechecked periodically.

Vigilance and thoroughness are key factors in equipment safety checks, since an official may be charged with notice of any deficiency he/she knew or should have known existed. If an equipment problem would have been discovered by a reasonable inspection, the meet director or the delegate may be deemed to have known about it, whether or not he/she actually discovers it. This is referred to as **constructive notice** of a defect, and it can be just as binding as **actual (direct) notice**. Therefore, since a meet director is responsible for defects discoverable by a reasonable inspection of the facility and

equipment, it is certainly preferable for a full inspection actually to be done, documented and defects corrected.

Equipment failures during a competition pose particular problems. A referee may have instantly to choose between stopping a diver doing an approach and take-off or letting the diver perform, depending on which course of action poses the least apparent danger to the diver. A referee or meet director may also have to decide if broken equipment can be replaced or repaired for use in sufficient time. If not, the contest should not be unduly delayed and the contest would have to proceed with the use of available safe equipment or cancelled.

## STATUTORY PROTECTION FOR VOLUNTEER OFFICIALS

In considering the potential liability of competition officials, it is worth noting that many states have adopted legislation which offers statutory protection against civil liability for competition officials in certain circumstances. Although these statutes differ in significant ways from state to state, most provide at least that volunteers working for non-profit/amateur athletic organizations shall not be liable to any person for civil damages resulting from the volunteer's conduct as an official, unless such conduct involves gross negligence or willful conduct. In 1989, for example, at least ten states either considered or passed legislation of this type. Individuals serving in a voluntary capacity as meet officials are encouraged to consult the applicable state law with regard to the availability and limits of some sort of statutory protection.

## SUMMARY

Because the competition rules play such a major part in determining the standard of care to which a meet official will be held, a distinction should be made between rule enforcement and rule enactment. Acting in the capacity of an official provides an opportunity to directly observe the specific influence rules have or fail to have over the safety of the divers. Officials should attend rules meetings and be ready to make recommendations to the appropriate rule-making bodies regarding the enactment of rules which minimize the risks to which the divers are exposed.

Perhaps the most important point to make with regard to the responsibility of the officials is that the health and safety of the diver must remain paramount. If the likelihood of an injury is considered remote, and its potential severity is regarded as being very minor, then other factors such as the diver's desire to participate, the potential for future advancement or contribution to team standing may be given weight in the decision-making process. As the likelihood of injury or the potential severity of such an injury increases, however, the issues of safety must be given absolute priority. Viewed in this context, the decision-making process is seen as being reasonable although by no means easy. When choosing between an irate coach whose diver's participation has been limited and a seriously injured diver, there is really no question of choice. While the former can result in a certain degree of consternation, the latter can result in an injury and major litigation as well.

## REFERENCES

- Davis VJ (1981) Sports liability: blowing the whistle on the referees. *Pacific Law Journal*. 12: 938-964.
- Feigley D, Dougherty NJ (1985) Legal responsibilities in gymnastics: potential areas of liability for gymnastics officials. In George, GS (ed.): *USGF Gymnastics Safety Manual*. Indianapolis, IN: The USGF Publications Department, pp. 13-16.
- Feigley DA, Heinzmann G (1988) Protection for coaches extended to municipal volunteers. *New Jersey Municipalities*, Nov. pp. 14, 38, 40.
- Heinzmann GS, Feigley DA (1987) Protecting volunteer coaches from lawsuits. *New Jersey Municipalities*, Oct. pp. 8, 36, 38, 40.
- Narol MS, Dedopoulos S (1989) Potential liability—a guide to referees' rights, *Trial*, Mar. pp. 18-21.
- Nygaard G, Boone TH (1981) *Law for Physical Educators and Coaches*. Salt Lake City, Utah: Brighton Publishing, pp. 119-120.
- State civil immunity legislation summaries and interpretations (1989) Rutgers Youth Sports Research Council.
- Walker WH (1990) Responsibilities of officials. In Gabriel JL, George GS (eds.): *U.S. Diving Safety Manual*. Indianapolis, IN: U.S. Diving Publications, pp. 12-17.
- Wilbur J (1983) Officials and liability. In *USGF Gymnastics*, Indianapolis, IN: United States Gymnastics Federation, November/December. 12 (6): 11-12.



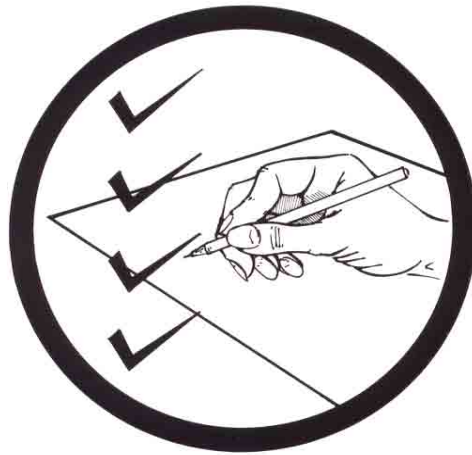

## CHAPTER II

# DOCUMENTATION RESPONSIBILITIES

by William H. Walker, Esq.

### CHAPTER COMPETENCIES

**Upon completion of this chapter, coaches and officials should be able to:**

- *Organize and maintain appropriate records as evidence, in accordance with established administrative procedures and based upon relevant legal requirements, in the event of legal challenges. Records should include assignments of personnel, practice plans, special safety measures, attendance of divers, emergency plans, safety rules/procedures, reports of injuries, copies of records of all oral and written communications concerning an injury or other unusual event.*
- *Inform those involved about the risks of diving by instructing divers and others concerned about the purpose of agreements to participate and the need for informed consent, medical information, medical release and medical emergency forms.*
- *Discuss the importance of adequate health and accident insurance coverage with divers and parents/guardians prior to participation and as needed at other times.*
- *Distribute participant accident insurance information to divers and parent/guardians and obtain liability insurance information for assistant coaches.*
- *Comply with existing requirements regarding insurance for diver participation and record evidence that all participants have such coverage.*
- *Require the completion of all necessary agreements and medical forms by divers and parents/guardians prior to participation.*
- *Use appropriate administrative forms related to physical examination for divers, emergency procedures, injury reports, program evaluation, etc.*
- *Keep a record of communications with health-care providers concerning the treatment of injured divers.*
- *Recognize the need for preparing and maintaining administrative records; maintain such records; store them for the required period of time.*
- *Complete and file an injury report for each medical emergency.*
- *Organize and conduct effective meetings before, during and after the season as needed to provide a group forum to communicate with divers, staff, parents/guardians about injury control and risk management problems.*
- *Conduct and document meetings regarding procedures for safety and emergency plans and guidelines for risk management.*
- *Cooperate with administrators and medical providers in developing and regularly reviewing a formal risk management plan.*
- *Properly complete all forms validating the eligibility of divers.*
- *Document formal and informal education as evidence of accumulated competence.*
- *Know sources of information that can be shared with assistant coaches and parent/guardians concerning the care and treatment of injured athletes.*
- *Encourage assistant coaches and parent/guardians to participate in educational programs that emphasize injury control, reporting and care of injuries.*
- *Maintain informal, personal contacts designed to collect information and keep open lines communication among all parties.*

Coaches and officials should keep written records of actions related to risk management, injury control, emergency response and care of injuries that document fulfillment of safety related responsibilities. The memory of events fades with time. What were once clear impressions may become confused or forgotten completely. Even recent events may be recalled differently by witnesses, especially when they involve traumatic injuries. The written record, however, is not subject to these problems. Sample forms are provided in this chapter's addenda. Additional information related to the use of these forms is available in the respective chapters. Forms may be utilized or adapted as needed.

## WARN OF INHERENT RISK

U.S. Diving club members must complete the U.S. Diving Amateur Athletic Waiver and Release of Liability form (see Figure 1.2, page 9). This form warns that each diver will be engaging in activities that involve risk of serious injury, including permanent disability and death. In addition, clubs may want to have their own club waiver and release of liability form specific to their organization. However, this supplemental club form will not replace the U.S. Diving Amateur Athletic Waiver and Release of Liability form for insurance purposes.

The U.S. Diving Amateur Athletic Waiver and Release of Liability form is included on the diver registration form which is available from U.S. Diving Registration Chairpersons. It must be completed and submitted to the Registration Chairperson *prior to* a diver's participation in lessons, training sessions or competitions.

Many coaches use team orientation meetings at the beginning of the season to explain safety and emergency plans and guidelines for risk management to be followed by divers. Team meetings during and after the season also provide a forum for discussion as needed. Coaches should record the date of the meeting, retain its agenda and attendance as documentation that appropriate warnings have been made.

## KEEP RECORDS

### Filing system

Organize a filing system to house forms associated with safety responsibilities and maintain pertinent forms for your counsel for at least ten years in the event litigation does occur.

### Insurance documentation

There are two types of insurance available through U.S. Diving to eligible members: Participant Accident and Liability. **Participant Accident insurance** is designed to pay those out-of-pocket expenses not paid by primary health insurance plans. It is available for injuries and accidents that occur as a result of participation in competitive diving activities. **Liability insurance** assists U. S. Diving (USD) and its officials or coach members with indemnity and defense costs (*attorney fees and court costs*) if:

- USD, an official or coach member, acting on behalf of USD in a scheduled supervised practice or sanctioned competition, is named in the complaint
- a claim is made which is covered by the policy
- the claim is not settled prior to court action unless with the consent of the insurer.

### Who and what is covered and when the insurance applies.

U.S. Diving participant accident insurance is secondary insurance coverage. Primary medical insurance for divers is provided by parents. There is always the risk that it may be terminated as a result of loss of employment or ineligibility. In some cases there are waiting periods before it may be reinstated. U.S. Diving participant accident insurance provides benefits after the primary accident plans have been exhausted. A diver, through his/her diver registration fee, automatically receives accident insurance for all supervised practices and sanctioned events. The diver's registration form must be completed and submitted along with the registration fee *prior to* participation. The need to pay medical expenses may prove to be strong motivation for a parent or diver to file a lawsuit arising from an injury sustained while participating in a sport. It is advisable that coaches be meticulous in the details of registering divers before their actual participation. The registration chairperson sends a receipt of registration to the applicant or coach to verify that the diver's registration has been received and processed. Incomplete information may delay the processing of the registration. Each diver is issued a unique registration number and receives a registration card.

U.S. Diving coaches and officials are automatically covered by liability insurance with their membership. This policy covers bodily injury and property damage claims. Clubs receive commercial general liability insurance coverage through their U.S. Diving membership. Diving facilities used for practice sessions or competitions may be named as additional insureds to the U.S. Diving commercial general liability insurance policy at no charge. Diving clubs should be aware that the liability coverage provided through their club membership *does not automatically* extend to the above-mentioned facilities without a *written* request and endorsement to the policy. Accident claim forms and applications for Third Party Liability coverage are available from the local registration chair or the USD national office.

Trampoline coverage is included according to the current guidelines for use (see pages 86-87).

What is not covered. Minitramps are excluded from coverage by USD insurance.

### Attendance documentation

Attendance records verify the absence or presence of a diver during a training session. Coaches who work with minors should be aware that lawsuits may be filed years after an injury has been sustained. Attendance records should be retained as they may prove crucial in the defense of a coach.

## Transportation documentation

Club coaches should have parents or divers provide their own transportation to and from practice and competition sessions whenever possible. Coaches should:

–know that many automobile personal liability policies will not be in effect if the coach accepts financial compensation or other benefits for transporting divers in his/her personal auto.

–check with their automobile insurance agent to determine if one needs to have a chauffeur’s license and possibly additional insurance coverage if divers are transported in one’s own personal auto.

High school and university coaches should be aware of their school/athletic department’s transportation policies. In many instances, the educational institution is responsible for transporting teams to away meets. Licensed commercial carriers are available. Many collegiate athletic departments have their own vans for transportation. Coaches must be aware of local and state laws pertaining to drivers of these vehicles.

If the coach travels by air with team members to an away meet and must arrange a rental car, he/she should check with one’s insurance agent to ascertain personal coverage and whether one should accept or decline the various coverages offered by the rental agency.

## Planning Documentation

Planning properly enables the coach to effectively fulfil his/her interrelated responsibilities. Coaches should formulate emergency action plans as well as instructional plans.

An emergency action plan establishes guidelines for appropriate action in an emergency. Documentation that provides emergency contact information and a record that consent has been obtained for medical treatment to a minor in the absence of the parent/guardian(s) (see page 23) are components of an emergency plan.

Follow up in the event of an emergency is also a component of a well thought out emergency action plan. Each coach/official may find it prudent to fill out an accident and/or incident report form (see pages 24-25) to record his/her actions, the names of his/her delegates and their duties, the status of equipment and complaints received, as well as the particular facts and witnesses concerning any injury which may occur during practice or competition. The documentation should be prepared as close to the event as possible and accurately reflect one’s personal observations and the content of any significant conversations. Document “facts” and avoid making opinions, conclusions or value judgments. All conclusions concerning fault or negligence should be avoided. It is not uncommon for a period of years to elapse between an injury and the resulting trial. **A good set of notes can assist in a complete, truthful and well-documented presentation by the official.** These reports should not be shared with others except on advice of one’s lawyer.

Session /season plans (see page 26) are prepared by the coach to structure the performance objectives, sequence of skill progression and time allotment for the conduct of the activity. Lesson plans (see page 27) detail the teaching methodologies and equipment used at the various training stations available at a particular facility to provide effective instruction. Preparticipation screening forms enable coaches to identify prior medical conditions that may present additional risk for athletes participating in diving. The information provided on these forms enables coaches to take individual limitations into consideration in the formulation of plans.

Training plans are generally built around competition schedules. To keep the lines of communication open, coaches should attend association meetings and maintain personal contacts with the local diving committee’s officers. Request to be placed on mailing or email lists to receive competition, clinic and meeting schedules and information. Circumstances may arise that require a change in plans.

## Implementation documentation

Documents that facilitate implementation of emergency and instructional plans have also been included in the chapter addenda. Coaches have responsibilities to provide a safe physical environment and proper equipment. Using facility and equipment inspection checklists (see pp. 28-30) and a maintenance repair request form (see page 31) helps the coach to identify potential safety concerns and document that he/she has taken action to correct the situation. Knowing in advance that a particular piece of equipment is not operational also enables the coach to modify the lesson plan accordingly.

The coach has a responsibility to provide adequate supervision and proper instruction. Coaches interact on site with pool managers, lifeguards and assistant coaches to deliver the program’s instructional plan. Coaches and supervisors are expected to have skills commensurate with the task. Coaches need to know the supervision responsibilities of the job and how these responsibilities are to be distributed among the staff. Examples of general and specific supervision risk management of diving coaches are included on page 93. A sample job description for various staff members is included in the addenda on page 32. Coaches are expected to set and enforce the rules. The safety guidelines for divers (see page 33) are intended to be a teaching aid.

The coach should be prepared to activate the emergency action plan and, if needed, to provide emergency care until professionals arrive. A sample deep water spinal injury management event sequence is included on page 175.

Even though physical readiness of the diver is a responsibility shared by coach, diver, parents and physician, the coach has a responsibility to know the diver’s skills and limitations. An Injury Report/Attending Physician’s Report on page 22 is included to assist the coach in obtaining return to activity authorization from the diver’s physician along with information about the diver’s limitations related to participation in the activity. In addition, dive/skill assessment documentation has been included on page 34 to assist the coach in assessing performer readiness.

## Eligibility Documentation

A diver's rights to participate are based on his/her eligibility. Eligibility requirements for U.S. Diving events are listed in the U.S. Diving Rules and Regulations. Coaches should enter only eligible divers in competition. Divers are responsible for the accuracy of the information submitted on the entry form and dive sheets. Coaches should check that forms validating the eligibility of the diver are properly completed.

## Injury Surveillance documentation

U.S. Diving coach members should submit a current U.S. Diving Injury Surveillance questionnaire (available from U.S. Diving) whenever a diver is injured regardless of whether insurance claims are filed. The information in this database provides U.S. Diving with information on injuries and the severity of injuries sustained in competitive diving. Encourage assistant coaches and parents/guardians to participate in the injury surveillance program. This information helps our coaches better understand the risks involved in competitive diving and thus provides information to better explain risks to the divers.

## Safety Competencies Documentation

In order to be eligible to apply for coach membership, a coach must document that he/she is current in first aid, CPR (adult and child) and U.S. Diving Safety Training for Competitive Diving Coaches. The United States Olympic Committee and U.S. Diving recommend that coaches take the American Red Cross (ARC) Sport Safety Training to meet first aid and CPR requirements. The ARC course is available through local ARC chapters. Equivalent courses are also acceptable. An updated list of current equivalent courses may be downloaded from the U.S. Diving website at: [www.usdiving.org](http://www.usdiving.org). U.S. Diving Safety Training for Competitive Diving Coaches courses are also listed on the U.S. Diving website. Encourage all diving coaches, parents/guardians and officials to participate in these courses. Use the reference texts for these courses as sources of information to share with assistant coaches and parent/guardians concerning emergency response and care of injured divers.

## SUMMARY

Keeping records facilitates the execution of the emergency action plan and the coach's instructional or training plan. Completed records housed in an organized filing system enable coaches quick access to information. The information collected may help coaches function efficiently and effectively in the office and on the pool deck. Easy accessibility of information relevant to the coaching tasks enables coaches to respond from an informed point of view while making daily decisions. Evaluation of written records may also provide a basis upon which modifications in emergency and season/lesson plans may be made to facilitate achievement of the intended outcomes.

## REFERENCES

- Gabriel JL, George GS (1990) U.S. Diving Safety Manual. Indianapolis, IN: U.S. Diving Publications.
- Johnston I (1997) A brief explanation of USD's insurance coverage. Indianapolis, IN: U. S. Diving Publications.
- Mair D (1997) United States Olympic Committee Risk Management Workshop, Colorado Springs, CO.
- Nygaard G, Boone TH (1985) Coaches Guide to Sport Law. Champaign, IL: Human Kinetics Publishers, Inc., pp 89-95.
- Seefeldt V, Maloy BP (1992) Insurance for athletes and coaches. In Seefeldt V, Brown EW (eds.) Program for Athletic Coaches' Education. Dubuque, IA: Wm. C. Brown Communications, Inc. pp. 26-1- 26-2.

## DOCUMENTATION ADDENDA

*(Special acknowledgments to Ben Rubin, M.D., Frank Gruber, M.D., Gerald S. George, Ph.D., John Wingfield and Russ Bertram related to the development of these documents.)*

The following documents described in this chapter are included in the addenda that follows:

- 3Preparticipation Screening Evaluation (p. 19)
- 3Preparticipation Screening Medical History (pp. 19-20)
- 3Preparticipation Screening Examination (p. 21)
- 3Injury Report/Attending Physician's Report  
*(Return to Activity Authorization)* (p. 22)
- 3Authorization to Consent to Treatment of a Minor (p. 23)
- 3Emergency Information (p. 23)
- 3Accident Report (p. 24)
- 3Incident Report (p. 25)
- 3Session Planner (p. 26)
- 3Lesson Plan (p. 27)
- 3Facility Inspection Checklist (p. 28)
- 3Equipment Inspection Checklist (pp. 29-30)
- 3Repair/Maintenance Request (p. 31)
- 3Diving Coaching Staff Job Description (p. 32)
- 3Pool Safety Guidelines for Competitive Divers (p. 33)
- 3Dive/skill assessment Chart (p. 34)

## SAMPLE – MEDICAL FORMS

What follows are medical forms which may be used in the Pre-participation Screening Evaluation (see pages 19-21) and for communicating with a physician regarding an injury (see page 22). The medical history portion of the Pre-participation Screening Evaluation should be completed by the diver as well as by his/her parents or guardians. Past medical history is extremely important in directing the physician in the physical examination. The examination portion of the Pre-participation Screening Evaluation must be completed by a physician.

The final form is the Injury Report Form (see page 22), the top of which should be filled out by the coach, or if present, a trainer. The lower part of the form, beginning with “Clinical Findings,” should be completed by the attending physician. The diver should also sign this form. This should be done to facilitate appropriate communication between the diver, coach, trainer, parent(s) or guardian(s), and physician related to return to activity.

### PREPARTICIPATION SCREENING EVALUATION

DATE OF EXAM \_\_\_/\_\_\_/\_\_\_

REFERRAL EXAM WITH \_\_\_\_\_

DIVER'S NAME \_\_\_\_\_  
(last) (first) (m.i.)

AGE \_\_\_\_\_ BIRTHDATE \_\_\_/\_\_\_/\_\_\_ ENTERING GRADE \_\_\_\_\_

DIVING CLUB/SCHOOL \_\_\_\_\_

BILLING ADDRESS \_\_\_\_\_

(city) (st) (zip)  
FAMILY DOCTOR \_\_\_\_\_ PHONE (\_\_\_\_) \_\_\_\_\_

ADDRESS \_\_\_\_\_

(city) (st) (zip)

INSURANCE CO. \_\_\_\_\_ GROUP # \_\_\_\_\_

NAME OF INSURED \_\_\_\_\_

EMPLOYER \_\_\_\_\_

If you are **presently under a doctor's care** for any reason (specialist's care for a specific ailment or for a chronic ailment) you will need to check with that physician and **obtain a release from that physician**, if needed, to participate in diving.

## PREPARTICIPATION SCREENING EVALUATION MEDICAL HISTORY

To be completed by diver and parent(s) or guardian(s)

DIVER'S NAME \_\_\_\_\_

**INSTRUCTIONS:** Please sit down with your parent(s) or guardian(s) and complete all questions. **CIRCLE** the appropriate answer. When a reply is **YES**, please give a complete explanation (give date of injury or treatment, indicate as near as possible the anatomical location of the injury i.e. Rt. shoulder, and the diagnosis) in the lines provided, or use the back of the page (be sure to list the question number) if more space is needed. All **YES** answers are to be fully explained!

After completing all the questions, both the diver and the parent(s) or guardian(s) are to sign the form on their appropriate lines. **THE PHYSICAL EXAM WILL ONLY BE GIVEN IF BOTH SIGNATURES ARE PRESENT!** Bring this signed, completed form with you on the day of the exam.

### DISEASE & ILLNESS

YES NO 1. Have you ever experienced an epileptic seizure or been informed that you might have epilepsy?

YES NO 2. Have you had hepatitis during the past three years?

YES NO 3. Have you been treated for infectious mononucleosis, viral pneumonia or another infectious disease during the past twelve months?

YES NO 4. Have you ever been treated for diabetes?

YES NO 5. Have you ever been treated or informed by a medical doctor that you have had rheumatic fever or scarlet fever?

YES NO 6. Have you ever been told that you have a heart murmur or high blood pressure?

YES NO 7. Have you had any illness requiring bed rest of one week or longer during the past year? If YES, give date and nature of illness. \_\_\_\_\_

YES NO 8. Have you ever been told you were anemic?

YES NO 9. Have you ever been told you had hemophilia, other bleeding disorders or currently have easy bruising or bleeding?

### EYES, DENTAL, EARS, NOSE, THROAT, SINUSES

YES NO 10. Do you wear eye glasses or contact lenses? If so, CIRCLE which. If contacts, CIRCLE soft or hard.

YES NO 11. If the answer to question 10 is yes, do you wear them during diving participation?

YES NO 12. Do you have poor vision in either eye? If YES, explain  
\_\_\_\_\_  
\_\_\_\_\_

YES NO 13. Do you wear any dental appliance? If answer is yes, underscore the appropriate appliance.  
Permanent bridge / permanent crown or jacket /  
removable partial / full plate

YES NO 14. Have you ever had ventilation tubes put in ears because of hearing loss and/or recurrent earaches as a child?

- YES NO 15. Do you have difficulty in clearing your ears during a plane trip, or at anytime there is a change in altitude?
- YES NO 16. Do you know how to keep water from rushing up into your nostrils so you do not have severe headaches on feet-first entries?
- YES NO 17. Do you get so called "swimmer's ears" frequently?

**GENERAL**

- YES NO 18. Have you ever been advised by a medical doctor not to participate in any athletic activity?
- YES NO 19. Have you ever been told that you have a hernia? If so, is it repaired? \_\_\_\_\_
- YES NO 20. Have you had any other operations during the past two years? If yes, indicate anatomical site of operation and date. \_\_\_\_\_
- YES NO 21. Have you had any additional illnesses or injuries during the past two years? If yes, indicate specific illnesses and dates. \_\_\_\_\_
- YES NO 22. Are you currently on prescribed medications or drugs on a permanent basis or semipermanent basis? If so, indicate name of drug and indicate how it was prescribed. \_\_\_\_\_
- YES NO 23. Are you allergic to any food or drug, or do you have any other allergies (nasal allergies)? \_\_\_\_\_
- YES NO 24. Do you have any missing body parts (eye, kidney, etc.)? \_\_\_\_\_
- YES NO 25. Do you smoke tobacco?
- YES NO 26. Do you use any drugs?
- YES NO 27. Do you use alcoholic beverages?
- YES NO 28. Have you had any problems with heat (stroke, exhaustion, etc.)? \_\_\_\_\_
29. Give the approximate date and name of the physician who gave you your last medical examination. \_\_\_\_\_

**IMMUNIZATIONS**

- YES NO 30. Have you completed oral polio immunization?
31. Date of:  
 (a) most recent tetanus immunization \_\_\_/\_\_\_/\_\_\_  
 (b) measles, mumps, rubella \_\_\_/\_\_\_/\_\_\_

**HEAD & NECK INJURIES**

- YES NO 32. Have you ever been "knocked out" or experienced a concussion during the past three years? If yes, give dates of all and if hospitalized. \_\_\_\_\_
- YES NO 33. Have you ever had any injury to the neck involving nerves, vertebrae (bones), or vertebral discs that has incapacitated you for a week or longer? If YES, give dates. \_\_\_\_\_

**BONE & JOINT**

- YES NO 34. Have you ever been treated for Osgood-Schlatter?
- YES NO 35. Have you ever been treated for osteomyelitis?
- YES NO 36. Have you had a fracture during the past two years? If yes, indicate the anatomical site of the fracture and date. \_\_\_\_\_
- YES NO 37. Have you had a shoulder dislocation, separation or other shoulder injury (bursitis, tendinitis) during the past two years that has incapacitated you for a week or longer?
- YES NO 38. Have you ever been advised to have surgery to correct a shoulder condition?
- YES NO 39. Have you ever experienced a severe sprain, dislocation or fracture to either elbow during the past two years? If yes, give the dates. \_\_\_\_\_
- YES NO 40. Have you ever had an injury to your back? If yes, did you seek the advice or care of a medical doctor? \_\_\_\_\_
- YES NO 41. Do you have spondylolysis (stress fracture of lower back) or spondylolisthesis? \_\_\_\_\_
- YES NO 42. Do you ever experience pain in your back? If yes, indicate frequency with which you experience pain by underscoring the answer: Very seldom / occasionally / frequently / only on vigorous exercise / heavy lifting
- YES NO 43. Do you think your back is weak?
- YES NO 44. Have you experienced a strain to either knee during the past two years with severe swelling accompanying the injury?
- YES NO 45. Have you ever been told that you had injured the ligaments of either knee joint?
- YES NO 46. Have you ever been told that you had injured the cartilage of either knee joint?
- YES NO 47. Have you ever been told that you have a 'trick' knee?
- YES NO 48. Have you ever been advised to have surgery to a knee to correct a condition?
- YES NO 49. Have you ever had any foot problems before such as pain in your feet while walking, running or standing?
- YES NO 50. Have you ever had shin splints or a stress fracture in your leg?
- YES NO 51. Have you had Achilles tendinitis?
- YES NO 52. Do you have weak ankles or have you ever sprained your ankles previous to this exam?

**PARENT(S) OR GUARDIAN(S)**

YES NO Is there any reason you feel your son or daughter should not participate in diving?

**PARENT(S) / GUARDIAN(S) / DIVER**

All of the above questions have been answered completely and truthfully to the best of our knowledge.

\_\_\_\_\_/\_\_\_\_\_/\_\_\_\_\_  
 (date) Parent(s) or Guardian(s) signature

\_\_\_\_\_/\_\_\_\_\_/\_\_\_\_\_  
 (date) Diver signature

## PREPARTICIPATION SCREENING EXAMINATION

DIVER'S NAME \_\_\_\_\_ HEIGHT \_\_\_\_ft. \_\_\_\_in. WEIGHT \_\_\_\_lbs.

BLOOD PRESSURE \_\_\_\_/\_\_\_\_ PULSE \_\_\_\_ TEMP \_\_\_\_ RESPIRATIONS \_\_\_\_

DIP URINE (if necessary as indicated by history): Sugar \_\_\_\_ Protein \_\_\_\_

GENERAL EXAM	SATIS	UNSATIS	MUSCULOSKELETAL	SATIS	UNSATIS
HEAD	_____	_____	ANKLES	_____	_____
EYES	_____	_____	KNEES	_____	_____
EARS	_____	_____	HIPS	_____	_____
HEARING	_____	_____	SHOULDERS	_____	_____
NOSE	_____	_____	HAND, WRIST	_____	_____
MOUTH	_____	_____	ELBOW	_____	_____
LYMPH NODES	_____	_____	NECK	_____	_____
CHEST/LUNGS	_____	_____	BACK	_____	_____
HEART	_____	_____	NEUROLOGICAL	_____	_____
ABDOMEN, LIVER, SPLEEN, KIDNEYS	_____	_____			
GENITALIA (no pelvic exam required)	_____	_____			
HERNIA	_____	_____			
SKIN	_____	_____			

**PHYSICIAN:** PLEASE COMMENT IN THE SPACE PROVIDED  
RE: ANY UNSATISFACTORY MARK.

FLEXIBILITY (N-Normal A-Adequate I-Inadequate)	RIGHT	LEFT
GROIN	_____	_____
QUADS	_____	_____
HAMSTRINGS	_____	_____
CALF	_____	_____
SHOULDERS	_____	_____
ELBOWS	_____	_____
BACK FLEXION	_____	_____
BACK EXTENSION	_____	_____

- CIRCLE ONE :**      **A   B   C   D**
- A** - Cleared for full diving participation
  - B**- Cleared pending re-exam of \_\_\_\_\_
  - C**- Cleared for restricted diving participation
  - D**- Denied clearance

I CERTIFY THAT THIS DIVER HAS BEEN EXAMINED BY \_\_\_\_\_

ON THIS DATE AND IS FOUND TO BE ABLE TO PARTICIPATE  
IN DIVING AS CLEARED ABOVE (A,B,C,D):

PHYSICIAN'S SIGNATURE \_\_\_\_\_ M.D.

DATE \_\_\_\_/\_\_\_\_/\_\_\_\_ PHONE (\_\_\_\_) \_\_\_\_\_

MEDICAL OFFICE \_\_\_\_\_  
\_\_\_\_\_  
\_\_\_\_\_  
(city) (st) (zip)

**INJURY REPORT**  
**ATTENDING PHYSICIAN'S REPORT**

Date \_\_\_\_/\_\_\_\_/\_\_\_\_

Diver's name \_\_\_\_\_

Age \_\_\_\_\_

Date of injury \_\_\_\_/\_\_\_\_/\_\_\_\_

**Completed by coach or trainer:**

Type of activity at time of injury \_\_\_\_\_

Describe injury \_\_\_\_\_

Initial treatment \_\_\_\_\_

**Completed by attending physician:**

Clinical findings \_\_\_\_\_

X-ray \_\_\_\_\_

Diagnosis \_\_\_\_\_

Treatment \_\_\_\_\_

**RECOMMENDATIONS**

No practice until seen by \_\_\_\_\_

No practice until \_\_\_\_\_

No contact until \_\_\_\_\_

Dry land only \_\_\_\_\_

Limited practice \_\_\_\_\_

No restrictions \_\_\_\_\_

**REHABILITATION**

Ice \_\_\_\_\_

Contrast \_\_\_\_\_

E.G.S. \_\_\_\_\_

Hot whirlpool \_\_\_\_\_

Hot pack \_\_\_\_\_

Ultra sound \_\_\_\_\_

Rehab program \_\_\_\_\_

Cold whirlpool \_\_\_\_\_

\_\_\_\_\_  
Physician's signature

\_\_\_\_\_/\_\_\_\_/\_\_\_\_  
date

\_\_\_\_\_  
Trainer's signature

\_\_\_\_\_/\_\_\_\_/\_\_\_\_  
date

\_\_\_\_\_  
Coach's signature

\_\_\_\_\_/\_\_\_\_/\_\_\_\_  
date

\_\_\_\_\_  
Diver's signature

\_\_\_\_\_/\_\_\_\_/\_\_\_\_  
date

**AUTHORIZATION TO CONSENT TO MEDICAL TREATMENT OF A MINOR CHILD**

We \_\_\_\_\_  
 and \_\_\_\_\_  
 do hereby state that we are the natural parents and/or have legal custody of \_\_\_\_\_,  
 age \_\_\_\_\_. We authorize \_\_\_\_\_  
 to consent to any examination, anesthetic, X-ray, medical or surgical diagnosis or treatment and/or hospital care to be rendered to the minor under the general or special supervision and on the advice of any physician or surgeon licensed to practice when efforts to contact us are unsuccessful.

This consent is granted for a period of one (1) year.

\_\_\_\_\_/\_\_\_\_\_/\_\_\_\_\_  
 (Parent or Guardian Signature) Date

\_\_\_\_\_  
 (Witness Signature)

\_\_\_\_\_/\_\_\_\_\_/\_\_\_\_\_  
 (Parent or Guardian signature) Date

\_\_\_\_\_  
 (Witness Signature)

**NOTARY**

City/County of \_\_\_\_\_

Commonwealth/State of \_\_\_\_\_

Acknowledged before me this \_\_\_\_day of \_\_\_\_\_ 19\_\_\_\_.

\_\_\_\_\_  
 (Notary Signature)

My commission expires \_\_\_\_\_ 19\_\_\_\_.

**EMERGENCY INFORMATION**

I, \_\_\_\_\_,  
 request that the following information be considered when medical treatment is rendered to \_\_\_\_\_,

Known allergies \_\_\_\_\_

Medication child is taking \_\_\_\_\_

Medical History \_\_\_\_\_

Choice of Hospital or Facility \_\_\_\_\_

Choice of Physicians (s) – include specialists \_\_\_\_\_

Child's Home Address \_\_\_\_\_

(City) (ST) (ZIP)

Phone (\_\_\_\_) \_\_\_\_\_

Parents or Guardians

Home Address \_\_\_\_\_

(City) (ST) (ZIP)

Child's Home Address \_\_\_\_\_

(City) (ST) (ZIP)

Phone (\_\_\_\_) \_\_\_\_\_

Possible location of parent(s) or guardian(s) (use pencil)

<u>Location</u>	<u>Phone</u>
Home _____	Phone (____) _____
Work _____	Phone (____) _____
Work _____	Phone (____) _____
Other _____	Phone (____) _____

Other Relative's Name	Relation	Phone
_____	_____	(____) _____
_____	_____	(____) _____

Signed \_\_\_\_\_/\_\_\_\_\_/\_\_\_\_\_  
 (Date)

# ACCIDENT REPORT

FACILITY \_\_\_\_\_

DATE/TIME OF ACCIDENT \_\_\_\_\_/\_\_\_\_\_/\_\_\_\_\_

## INJURED PERSON (S)

1. Name \_\_\_\_\_ Age \_\_\_\_\_  
Address \_\_\_\_\_

\_\_\_\_\_  
(city) (st) (zip)  
Phone (\_\_\_\_\_) \_\_\_\_\_

2. Name \_\_\_\_\_ Age \_\_\_\_\_  
Address \_\_\_\_\_

\_\_\_\_\_  
(city) (st) (zip)  
Phone (\_\_\_\_\_) \_\_\_\_\_

CHECK ONE \_\_\_\_\_ DIVER \_\_\_\_\_ SPECTATOR

\_\_\_\_\_ OTHER \_\_\_\_\_

## PARENT OR GUARDIAN (especially if injured is a minor)

Name \_\_\_\_\_  
Address \_\_\_\_\_

\_\_\_\_\_  
(city) (st) (zip)  
Phone (\_\_\_\_\_) \_\_\_\_\_

## WHO WAS NOTIFIED OF ACCIDENT?

Name \_\_\_\_\_  
Address \_\_\_\_\_

\_\_\_\_\_  
(city) (st) (zip)  
Phone (\_\_\_\_\_) \_\_\_\_\_

## STATE IN DETAIL HOW ACCIDENT OCCURRED

Please give all information possible relating to accident whether due to carelessness of the injured person, violation of safety regulations, etc.

\_\_\_\_\_  
\_\_\_\_\_  
\_\_\_\_\_

## HOSPITAL TO WHICH INJURED PERSON WAS TAKEN

Name \_\_\_\_\_  
Address \_\_\_\_\_

\_\_\_\_\_  
(city) (st) (zip)  
Phone (\_\_\_\_\_) \_\_\_\_\_

WAS RESUSCITATION ADMINISTERED? \_\_\_\_\_

FOR HOW LONG? \_\_\_\_\_

## WHAT TREATMENT WAS GIVEN TO INJURED PERSON?

\_\_\_\_\_  
\_\_\_\_\_

## WITNESSES

1. Name \_\_\_\_\_ Age \_\_\_\_\_  
Address \_\_\_\_\_

\_\_\_\_\_  
(city) (st) (zip)  
Phone (\_\_\_\_\_) \_\_\_\_\_

2. Name \_\_\_\_\_ Age \_\_\_\_\_  
Address \_\_\_\_\_

\_\_\_\_\_  
(city) (st) (zip)  
Phone (\_\_\_\_\_) \_\_\_\_\_

SUPERVISED? \_\_\_\_\_ YES \_\_\_\_\_ NO

SUPERVISOR'S NAME \_\_\_\_\_

SIGNED \_\_\_\_\_

DATE \_\_\_\_/\_\_\_\_/\_\_\_\_

TITLE \_\_\_\_\_

## INCIDENT REPORT

FACILITY \_\_\_\_\_ DATE/TIME OF INCIDENT \_\_\_\_/\_\_\_\_/\_\_\_\_ a.m. p.m.

ADDRESS \_\_\_\_\_

PHONE (\_\_\_\_) \_\_\_\_\_

(city) \_\_\_\_\_ (st) \_\_\_\_\_ (zip) \_\_\_\_\_

EXACT LOCATION OF INCIDENT \_\_\_\_\_

LIGHTING AND WEATHER CONDITIONS PREVAILING \_\_\_\_\_

### PEOPLE INVOLVED IN THE INCIDENT

1. Name \_\_\_\_\_ Age \_\_\_\_\_

Address \_\_\_\_\_

Phone (\_\_\_\_) \_\_\_\_\_

(city) \_\_\_\_\_ (st) \_\_\_\_\_ (zip) \_\_\_\_\_

2. Name \_\_\_\_\_ Age \_\_\_\_\_

Address \_\_\_\_\_

Phone (\_\_\_\_) \_\_\_\_\_

(city) \_\_\_\_\_ (st) \_\_\_\_\_ (zip) \_\_\_\_\_

### STAFF INVOLVED IN THE INCIDENT

1. Meet Director \_\_\_\_\_ 2. Referee \_\_\_\_\_

3. Pool Manager \_\_\_\_\_ 4. Other supervisory personnel \_\_\_\_\_

WAS ANYONE INJURED? \_\_\_\_\_ YES \_\_\_\_\_ NO *If yes, attach the Accident Report*

### DETAILS OF INCIDENT

Equipment status \_\_\_\_\_ Surface description \_\_\_\_\_

Last person to inspect the location/equipment: \_\_\_\_\_ Inspection Date/Time \_\_\_\_\_

Description of incident: \_\_\_\_\_

### DETAILS OF STAFF ACTION

Name of First Aid giver before paramedics arrived: \_\_\_\_\_

Description of Pool Staff Actions \_\_\_\_\_

WAS THE SUPERVISOR NOTIFIED? \_\_\_\_\_ YES \_\_\_\_\_ NO If yes, when \_\_\_\_\_

WERE THE PARAMEDICS NOTIFIED? \_\_\_\_\_ YES \_\_\_\_\_ NO

If yes, Paramedic's Name \_\_\_\_\_ Paramedic Report # \_\_\_\_\_

WERE THE POLICE NOTIFIED? \_\_\_\_\_ YES \_\_\_\_\_ NO

If yes Police Officer's Name \_\_\_\_\_ Police Report # \_\_\_\_\_

COMMENTS BY SUPERVISOR \_\_\_\_\_

SIGNED \_\_\_\_\_ CLASSIFICATION \_\_\_\_\_

# SESSION PLANNER

WK	Session Days Times										Coach													
	Level: I	II	III	JONT	SRNT	Number of Divers					Assistant Coach													
	MO	TU	WE	TH	FR	SA	SU	Entries	Comeouts	Connection	Take-off	Approach Fwd/Bwd	Arm Swing	Approach Fwd/Bwd	Take-off	Connection	Comeouts	Entries	Basic Dives	Somersaulting Dives	Twisting Dives	Conditioning	Flexibility	
1																								
2																								
3																								
4																								
5																								
6																								
7																								
8																								

### LESSON PLAN

MIN	I/R/M	OBJECTIVES	CUES	PRACTICE METHODS	TRAFFIC CONTROL	QTY	TRAINING STATION
		1. Greeting					GRD MAT FLP TR DB PS IMS 3MS 1MP 3/5MP 10MP
		2. Review					GRD MAT FLP TR DB PS IMS 3MS 1MP 3/5MP 10MP
		3. New Skills					GRD MAT FLP TR DB PS IMS 3MS 1MP 3/5MP 10MP
		4. Principles/Handout					GRD MAT FLP TR DB PS IMS 3MS 1MP 3/5MP 10MP
		5. Arm Swing					GRD MAT FLP TR DB PS IMS 3MS 1MP 3/5MP 10MP
		6. Approach Fwd/Bwd					GRD MAT FLP TR DB PS IMS 3MS 1MP 3/5MP 10MP
		7. Take Off					GRD MAT FLP TR DB PS IMS 3MS 1MP 3/5MP 10MP
		8. Connection					GRD MAT FLP TR DB PS IMS 3MS 1MP 3/5MP 10MP
		9. Comeouts					GRD MAT FLP TR DB PS IMS 3MS 1MP 3/5MP 10MP
		10. Entries					GRD MAT FLP TR DB PS IMS 3MS 1MP 3/5MP 10MP
		11. Basic Dives					GRD MAT FLP TR DB PS IMS 3MS 1MP 3/5MP 10MP
		12. Somersault Dives					GRD MAT FLP TR DB PS IMS 3MS 1MP 3/5MP 10MP
		13. Twisting Dives					GRD MAT FLP TR DB PS IMS 3MS 1MP 3/5MP 10MP
		14. Conditioning					GRD MAT FLP TR DB PS IMS 3MS 1MP 3/5MP 10MP
		15. Flexibility					GRD MAT FLP TR DB PS IMS 3MS 1MP 3/5MP 10MP

Facility \_\_\_\_\_

## SAFETY INSPECTION CHECKLIST DIVING FACILITY

Date \_\_\_\_/\_\_\_\_/\_\_\_\_

\_\_\_\_\_  
Inspection Supervisor

	Item	1m		3m		5m		7.5m		10m	
		OK	Repair	OK	Repair	OK	Repair	OK	Repair	OK	Repair
Platform	non-slip surface										
	runway										
	joined covering										
	leading edge										
	rails										
	perimeter										
	stairs										
Comments											
		Pool 1		Pool 2		Dryland Area		Locker Room		Spa/Hot Tub	
	<b>Item</b>	OK	Repair	OK	Repair	OK	Repair	OK	Repair	OK	Repair
Facility	bleachers										
	entry/exits										
	telephone										
	storage										
	clean										
	adequate										
	artificial lighting										
	windows										
	surface agitation										
	internal pool surface										
	pool deck (tiles)										
Comments											

Facility \_\_\_\_\_

## SAFETY INSPECTION CHECKLIST DIVING EQUIPMENT

Date \_\_\_\_/\_\_\_\_/\_\_\_\_

\_\_\_\_\_  
Inspection Supervisor

Equipment	Item	Apparatus 1		Apparatus 2		Apparatus 3		Apparatus 4	
		OK	Repair	OK	Repair	OK	Repair	OK	Repair
1/2m Board	non-slip surface								
	bolts secure								
	level								
	cracks								
	fulcrum								
	ladder								
	Comments								
1m Board	non-slip surface								
	bolts secure								
	level								
	cracks								
	fulcrum								
	ladder								
	Comments								
3m Board	non-slip surface								
	bolts secure								
	level								
	cracks								
	fulcrum								
	ladder								
	Comments								
Hydraulic Board	non-slip surface								
	bolts secure								
	level								
	cracks								
	fulcrum								
	ladder								
	Comments								
Dryboard	non-slip surface								
	bolts secure								
	level								
	cracks								
	fulcrum								
	ladder								
	Comments								
Trampoline	bed								
	springs								
	frame								
	Comments								

Facility \_\_\_\_\_

## SAFETY INSPECTION CHECKLIST DIVING EQUIPMENT

Date \_\_\_\_/\_\_\_\_/\_\_\_\_

\_\_\_\_\_  
Inspection Supervisor

Equipment		Apparatus 1		Apparatus 2		Apparatus 3		Apparatus 4	
		OK	Repair	OK	Repair	OK	Repair	OK	Repair
Basic Mats	edges								
	velcro								
	sewing								
	cover condition								
	padding								
	Comments								
Landing Mats	edges, handles								
	sewing								
	cover condition								
	foam filler & pad								
	Comments								
Portable Landing Pit	clean of debris								
	adequate foam								
	vinyl encasement								
	mesh encasement								
	cover								
	Comments								
Safety Equipment	handbelts								
	overhead spot rig								
	girder clamps								
	hooks/cables								
	turnbuckles								
	pulleys & axles								
	swivel clips								
	ropes								
	uniaxial belt								
	biaxial belt								
	underpads								
	Comments								
Sparging System	air pressure								
	bubble mound								
	pipes								
	holes								
	Comments								

**REPAIR AND MAINTENANCE REQUEST FORM**

Date \_\_\_\_/\_\_\_\_/\_\_\_\_ Time \_\_\_\_\_ Reported by \_\_\_\_\_

**ITEM(S) NEEDING REPAIR**

\_\_\_\_\_  
\_\_\_\_\_  
\_\_\_\_\_  
\_\_\_\_\_

**LOCATION (AREA/ROOM #)**

\_\_\_\_\_  
\_\_\_\_\_  
\_\_\_\_\_

Approved by \_\_\_\_\_  
*(authorizing supervisor)*

Date \_\_\_\_/\_\_\_\_/\_\_\_\_

A work order has been submitted to:  
\_\_\_\_\_  
\_\_\_\_\_  
\_\_\_\_\_  
\_\_\_\_\_

Account Number \_\_\_\_\_

**U.S. DIVING CLUB COACHING STAFF**  
**Example – Job Description**

**POSITION**

**RESPONSIBILITIES**

---

---

**HEAD SENIOR DIVING CLUB COACH**

Liaison to head swim coach and pool manager  
Liaison to NGB and booster club  
Oversee all coaching staff  
Oversee all levels of diving program  
Supervise senior divers  
Schedule lessons and workouts  
Coordinate competition and travel with seniors' parents  
Develop training plans for junior and senior divers  
Spot senior divers on tramp, dryboard and 3m wetboard  
Inspect equipment  
Submit maintenance requests to pool manager  
Order new equipment  
Coordinate fund-raising efforts with booster club  
Meet with Sports Science/Medicine consultants  
Perform administrative duties related to business office  
Unlock and set up equipment for use each morning  
Unlock and secure facility when appropriate

---

**HEAD JUNIOR DIVING COACH**

Identify talented divers in the community  
Recruit talented divers into the diving club  
Supervise junior divers  
Coordinate facility use with Head Senior Coach  
Coordinate competition and travel with juniors' parents  
Spot junior divers on tramp, dryboard and 3m wetboard  
Implement training plans for juniors  
Meet with Sports Science/Medicine consultants  
Perform administrative duties related to business office  
Supervise locker rooms  
Check equipment prior to use  
Secure equipment at the end of the day  
Unlock and secure facility when appropriate

---

**LESSONS COACH**

Teach lessons program  
Supervise lessons program divers  
Assist Head Junior Coach with recruiting talented divers  
from the lessons program to the junior team  
Take and turn in attendance to head junior coach

# POOL SAFETY GUIDELINES FOR COMPETITIVE DIVERS

**ASSUME RISK** – Understand and appreciate the risks involved before engaging in any diving activity. **WARNING!** Catastrophic injury, paralysis, or even death can result from improper conduct of diving activity.

**KEEP RECORDS** – Register as a U.S. Diving athlete member before your first lesson or training session. Take your U.S. Diving registration card to competitions for verification if needed.

**PLAN YOUR DIVE AND WATER ENTRY** – Plan your dive to land a safe distance from the board or platform in water deep enough for you to maneuver underwater. Visualize your dive before you perform. Be ready to go when its your turn. Dive straight off the board or platform. Entry techniques may vary according to the pool bottom configuration, depth, height of the board or platform and dive. On head-first entries grab your hands to protect your head, neck and spine. Avoid striking the head and neck on the bottom. Know what glide path to follow underwater. Know where to exit the water.

**CHECK THE POOL DEPTH BEFORE YOU DIVE** – Check the pool depth and water envelope for obstructions or another swimmer or diver before every dive. Ease into an unfamiliar pool or body of water the first time. Enter the deep water in the diving area feet-first the first time in an unfamiliar diving facility.

**CHECK EQUIPMENT BEFORE YOU DIVE** – Check that the bolts in the end of the diving board are secured. Check that your fulcrum setting is readied for your dive. Check that the takeoff surface is not slippery. Report any unsafe conditions immediately to a coach or lifeguard.

**BE SUPERVISED** – Do not swim or dive without a lifeguard or coach present. Do not use the dryland training equipment without a coach present. Do not dive off the platform until you are cleared for takeoff by a coach.

**FOLLOW PROPER DIVING SKILL PROGRESSIONS** – Master the basic diving skills first. For dives that are too complex for beginners to learn as a whole, develop skill mastery in the separate component parts, alternate between part and whole practice and continue to refine the parts.

**KNOW YOUR LIMITATIONS** – Fatigue, illness, alcohol or drug use can increase the risk of injury. Use good judgment to match your capabilities to the task difficulty. Get a preparticipation screening exam from a physician. Discuss any limitations with your coach. Be physically and psychologically ready for participation in any diving activity. Warm up. Your physical conditioning level should match the demands of the skills. The best indicator of readiness to perform is a diver's ability to safely perform a basic lead-up skill with similar mechanical requirements. Demonstrate good balance, safe distance, spatial orientation, sufficient strength, and good form to your coach. Consult with your coach before attempting a new or difficult skill. Avoid overtraining.

**KNOW AND FOLLOW POOL RULES** – Know and follow the rules for pool users in each facility you dive.

**NO HORSEPLAY** – Concentration is necessary from the initial step up the ladder until the final climb out of the pool. No double bouncing the springboard, unless performing drills for control under the direct supervision of your coach.

**KNOW EMERGENCY PROCEDURES** – Whenever a diver strikes the head, it must be assumed that a neck injury is involved. Cooperate with the coach or lifeguard in the case of an injury or emergency.



**SAFETY POSTER I** – For more information about competitive diving or additional educational materials, contact: U.S. Diving, Pan American Plaza, 201 S. Capitol Ave., Suite 430, Indianapolis, IN 46225  
Tel: 317/237-5252 Email: [usdiving@usdiving.org](mailto:usdiving@usdiving.org) Website: [www.usdiving.org](http://www.usdiving.org)

# DIVE/SKILL QUALITY ASSESSMENT

DATE \_\_\_/\_\_\_/\_\_\_ DIVER: \_\_\_\_\_

GRADE	A	B	C	D
SCORE	8 - 10	7 - 7.5	6 - 6.5	4 - 5

1, 3 or 10m	DIVE #												N =
Dive Quality	ORDER	1	2	3	4	5	6	7	8	9	10	11	List Quality
	REPS	ABCD	ABCD	ABCD	ABCD	ABCD	ABCD	ABCD	ABCD	ABCD	ABCD	ABCD	
Overall Dive	1												Overall List
	2												
	3												
	4												
	5												
GRADE	A												
	%												
	B												
	%												
	C												
	%												
Good Balance	1												
	2												
	3												
	4												
	5												
Skill Quality	Yes												
	%												
Safe Distance	1												
	2												
	3												
	4												
	5												
Skill Quality	Yes												
	%												
Spatial Orientation	1												
	2												
	3												
	4												
	5												
Skill Quality	Yes												
	%												
Sufficient Strength	1												
	2												
	3												
	4												
	5												
Skill Quality	Yes												
	%												
Good Form	1												
	2												
	3												
	4												
	5												
Skill Quality	Yes												
	%												
Rip Entry	1												
	2												
	3												
	4												
	5												
Skill Quality	Yes												
	%												

# SECTION II: INJURY CONTROL FOR DIVING COACHES

## SECTION STANDARDS

### Upon completion of this section, coaches should know:

- *To plan and coordinate procedures for appropriate emergency care.*
- *To design programs of training and conditioning that properly incorporate the mechanics of movement and sound physiological principles taking into account each individual's ability and medical history, avoiding contraindicated exercises and activities and guarding against the possibility of overtraining; be able to modify programs as needed.*
- *To control exposure to the risks of injuries by considering the effects of environmental conditions on the circulatory and respiratory systems when planning and scheduling practices and competitions and implementing programs for physical conditioning.*
- *To organize, conduct and evaluate practice sessions with regard to established program goals that are appropriate for different stages of the season.*
- *To reduce the number and minimize the magnitude of injuries by recognizing and insisting on safe conditions for training and competition.*
- *To implement diving programs with organizational and administrative efficiency.*
- *To verify that safety belts are in good condition, fit properly and are worn as prescribed by the manufacturer.*
- *To verify that equipment and facilities meet required standards of the appropriate governing body for competition.*
- *To understand the scope of the legal responsibilities that comes with assuming a coaching position, e.g. adequate supervision, proper planning and instruction and matching participants.*
- *The key elements of sport principles and technical skills as well as the various teaching methods that can be used to introduce and refine them.*
- *To use objective and effective procedures for evaluation and selection of personnel involved in the diving program and for periodic program reviews.*
- *To analyze diver's performances in terms of developmental information and individual body structure.*
- *To provide instruction to develop sport specific motor skills. Refer divers to appropriate counsel as needed.*
- *To provide learning experience appropriate to growth and development of the age group coached.*
- *To recognize that proper conditioning and good health are vital to control of diving injuries.*
- *The basics regarding physiological systems and their responses to training and conditioning.*
- *To facilitate a unified injury control, care and management program by coordinating the roles and actions of the coach, a National Athletic Trainers Association certified athletic trainer, if available, with those of the physician.*
- *To demonstrate skill in injury control; to assist divers with the recovery/rehabilitation from diving related injuries in accordance with the guidelines provided by qualified medical personnel.*





## CHAPTER III

# PLANNING RESPONSIBILITIES

### CHAPTER COMPETENCIES

**Upon completion of this chapter, coaches should be able to:**

- Follow safety guidelines, procedures and risk management plans established by the program administrator.
- Know the details involved in an emergency plan for diving.
- Develop and maintain a system for keeping diver's records current and secure.
- Maintain appropriate medical records for each diver, including medical information or physical screening and evaluation forms and treatment consent forms and have them available during all practices and competitions.
- Complete and file an injury report form for each medical emergency.
- Have available a written emergency plan for all sites where practice and competition occur.
- Have a first aid kit available at all practices and competitions; know its contents and appropriate uses; know the location of the nearest telephone.
- Prepare practice plans that take dangerous environmental factors into account; be prepared to limit activity to reduce risk.
- Prepare practice plans that indicate where and when dangerous situations may arise and tell how these situations are to be managed.
- Understand the psychological consequences of injury and assist athletes in dealing with them.
- Know how to recognize psycho-social distress and the resources available to assist athletes.
- Know and educate divers and parent/guardians how social psychological problems may increase susceptibility to injuries or influence recovery.
- Be aware of social-psychological issues that may affect athletes of different ages in contemporary society such as violence, emotional stress, etc.
- Know the key elements of effective practice plans.
- Acquire or prepare season objectives that reflect the physical and mental development levels of divers.
- Determine which skills in each area of the sport experience-physical skills, knowledge, fitness and personal/social skills-are to be taught at each level within the total program.
- Arrange these skills and introduce them in a logical sequence; use a seasonal planning calendar to indicate when each skill will be taught.
- Select specific drills and activities that allow the divers of various levels to experience success.
- Use a variety of activities to help divers of various levels of ability develop specific skills.
- Develop practice plans that allow for all athletes to learn new skills at their own pace and within their own limits.
- Choose drills and practice plans that allow divers the opportunity to improve within their physical and mental-emotional limits.
- Organize activities so that divers have an opportunity to develop and maintain positive feelings of self-worth.
- Prepare a season coaching plan that indicates when and how conditioning will take place.
- Summarize and analyze success and areas needing improvement after the competitive season.
- Understand that coaching effectiveness is determined by the degree to which divers meet previously established objectives.
- Evaluate the effectiveness of coaching techniques used as they relate to the performance of divers.

# Part 1. Emergency Plans

by Frank W. Gruber, M.D. and Gerald E. DeMers, Ph.D.

## COACH'S ROLE

Proper planning provides another safeguard woven into each diver's safety net. Coaches need to be aware of their roles and expectations related to lifeguards and assistants, emergency action plans, and policies and procedures manuals. If an injury were to occur, the supervisor should have a plan in place to deal with the emergency to minimize the extent of the injury. Preparation and planning are necessary both to minimize the potential for injuries and to care for them if they occur.

The worst possible scenario is for a catastrophic injury to occur, and for the rescuers to make that injury worse by mismanagement and/or by not being up to date on current rescue techniques. All too often, unfortunately, the victim of a shallow water entry spinal cord injury is removed from the pool without a backboard by other recreational swimmers who are unaware that their friend has sustained a fractured neck (Gabrielsen & Spivey (1990); Gabriel (1992).

Coaches are considered lay responders, i.e. rescuers or first aiders, who provide **care**. Coaches are not expected to provide **treatment**, which is care rendered by professional medical personnel. Coaches are not expected to have the medical expertise of a fully trained and licensed medical provider or practitioner.

## Define Roles and Expectations of Lifeguards and Assistants

The requirement to deploy lifeguards varies from state to state, and sometimes even between counties. Not all diving programs have a lifeguard on deck for all diving activities. Having a lifeguard is potentially helpful but agencies who train lifeguards do not address rescue methods specific to competitive diving injuries. This program was designed to provide you with the skills and knowledge necessary to identify a distressed, drowning or unconscious victim and perform rescues appropriate for injuries which occur in a competitive diving environment.

If you are fortunate enough to have a lifeguard assigned for your use, you should coordinate responsibilities with the lifeguard. Make sure they are observant and positioned where they have the best view of the entire diving area. Coordinate efforts with the lifeguard's employer or aquatic director to make sure the program receives the best possible surveillance. The only duty of the lifeguard is to guard the activity. Lifeguards should not be used as assistant coaches or have other duties assigned during the time they are on duty.

If you have assistant coaches in your program, make sure they understand all policies and procedures relating to safety

for the program. It is advisable that assistants receive this training program so that they are aware of their key responsibilities. Since the head diving coach is responsible for the actions of the assistant, the assistant should understand the philosophy and expectations of the head coach (see page 32).

## EMERGENCY ACTION PLANS

### Facility Emergency Action Plan

**An Emergency Action Plan (EAP) establishes guidelines for appropriate action in an emergency. An effective emergency action plan consists of clear guidelines for responsibilities during rescue activities following an injury and the order in which specific actions take place. This emergency plan should be posted at your diving facility and also located in your policies and procedures manual. These policies should be shared and rehearsed with other participants (divers, assistant coaches, and lifeguards, if available) in your program.**

The following is an example of an emergency action plan:

1. Coach identifies the emergency and acts (Calls Out) for additional staff/divers to assist in EAP  
(Assesses situation and injury)  
(Initiates appropriate rescue)
2. Victim moved to safety (shallow water or side of pool)
3. Thoroughly assesses victim's condition
4. Victim O.K. Equipment checked and replaced  
Any corrective action taken  
Complete accident/incident report  
Return to coaching  
Staff discussion: cause of injury, relation to activity, equipment, facility, emergency response, rescue response, equipment availability, transport, treatment  
Victim Needs Care  
Other divers and assistant coaches assist  
First aid provided  
EMS notified by team member  
Clear the diving pool if necessary  
Supervisor notified  
Witnesses interviewed  
Equipment checked and replaced  
Any corrective action taken  
Complete Accident/Incident Report  
Return to coaching  
Staff discussion

There must be a telephone readily accessible at the facility. If not, the diving coach should carry a cellular phone.

Emergency numbers should be posted at the same location as the telephone. It is also helpful to post a script which can be read to EMS. In this script include pool location, address, how to enter the facility, pool phone number, type of injury (broken bone, unconscious, spinal injury). In a state of panic, it is sometimes difficult to communicate effectively. A script posted near the telephone will facilitate the call to EMS.

An emergency action plan should be practiced periodically in order to determine its efficacy. Practicing helps identify problems with the plan and assists in constructing the best plan possible. A plan may include participants in the program, parents, bystanders, other facility staff and assistants. Your plan should be tailored to your facility and program.

### **Competitive Diving Program EAP**

The facility may have several EAPs but they may not relate directly to competitive diving. Your diligence in developing one will be of great assistance if an accident does happen.

The coach should be aware of four risk management strategies for control of injury: (1) assess performer readiness, (2) maintain a file of information on all divers which might be necessary in an emergency, (3) prepare an emergency plan of action with contingencies for both minor injuries and major or life threatening injuries, (4) provide an individual who has the training and necessary equipment to render first aid and cardiopulmonary resuscitation (CPR) if necessary.

### **PREPARTICIPATION SCREENING EVALUATION**

The coach should first require an athletic **Preparticipation Screening Evaluation** (p. 19) including a **Medical History** (p. 19-20) and a **Physical Screening** (p. 21) performed by a licensed physician. The Medical History should include any known medical conditions or handicaps that might need to be taken into consideration in assessing performer readiness for workouts or competition. Some conditions are less obvious and may be more difficult to detect than others. The coaching staff should be aware of past medical problems such as previous injuries or operations, and any existing medical conditions that might suddenly present an emergency. Examples of existing conditions which may place a diver at risk include diabetes, in which the diver is taking insulin and might have an adverse reaction and end up suddenly confused or in a coma, or epilepsy in which the diver may suddenly have a seizure. These are but a few of the problems that might be identified. The Medical History (Questions 19, 20, and 21) should also note allergies and current medications taken on a regular basis.

For divers participating in competitive diving programs, the physical screening should be a complete “head to toe” exam in which all areas of the body are examined, rather than a cursory exam limited to the heart, lungs and abdomen. The sample preparticipation screening forms may be copied and taken to the physician as an example of the type of exam required. Most physicians performing athletic physicals will complete the form given to them. In addition to the physician’s

standard physical exam, these particular sample forms alert the physician to injuries and illnesses which may specifically affect performer readiness in diving. In most cases, it is recommended that the primary care physician (pediatrician or family physician) perform the screening (Micheli & Jenkins, 1990), however the preparticipation evaluation may be performed in a physician’s office or in a multi-station, mass screening evaluation (Preparticipation Physical evaluation, 1992).

Coaches with a number of divers may be able to form relationships with particular physicians so that doctors become increasingly more attuned to specific diving problems. Likewise, as these relationships grow, coaches often give the physicians insights into divers’ personalities and problems that doctors might not be able to elicit in the limited time they have to spend with the divers.

### **DIVER INFORMATION FILE**

Once the preparticipation screening evaluation has been done, a file should be created for each diver. It should include a copy of the divers’ preparticipation screening forms, and both the Medical History and Physical Screening forms. All diving programs should require a consent for medical treatment of a minor form. The **consent for medical treatment form** (see p. 23) should be signed by parent(s) or guardian(s) of underage divers. This form should be kept on file and be easily accessible to the coach and assistant coaches during workouts and also taken with the coach/chaperone to all away competitions. It is advisable to consult with an attorney regarding the wording of this form. The following additional **Emergency Information** (see p. 23) could feasibly be kept on a single card carried in a file box or in some other convenient way to competitions, and would be readily accessible on a moment’s notice: (1) current name, address, and telephone number of the diver, (2) current name, address, and telephone numbers (work and home) of parents or guardians whether the diver is a minor or not, (3) name, address, and phone number of athletic personnel, preferred family physician, and orthopedist for each diver, and (4) a record of medications, medical problems and allergies of each diver.

The following data might be kept with the completed medical history and physical examination form in a permanent file and not necessarily travel with the coach to workouts and meets:

(1) history of diving participation in the past, (2) injury report form (p. 22) that documents details of the injury (when, where, what, how), dates and findings of medical exams or referral exams, and specific dates the diver is released for practice, and (3) any observations the coach might like to make about the diver’s performance that would help to assess safe participation.

### **Emergency plans for accident or injury**

Once the diver information file is complete, the groundwork is laid for an accident or injury emergency plan. The plan should be written, specific, and in place before an activity begins. It should include procedures to follow if an accident

occurs at the home pool as well as what action to take if an accident occurs while traveling to an away pool. The plan should also consider both minor injuries or illnesses and major catastrophic injuries, and what to do in each case. These plans can be relatively simple and written in an outline form.

An emergency plan should include the following:

1. The phone number of the diver's family physician or orthopedist (listed on each individual's file card). Carry change in order to make the emergency phone call. Tape the change to the inside of the diver medical form file box or the medical kit.
2. The names and telephone numbers of other local family physicians, team physicians and orthopedists with whom the coach has some rapport, who might be available in an emergency either for advice or to see an injured diver.
3. The names and telephone numbers of the local hospital emergency rooms.
4. The names and telephone numbers of local emergency ambulance services. Please note there are some ambulance services that transport non-emergencies only. These take a long time to arrive and have minimally trained personnel. Verify that you have the number of the emergency rescue service. These emergency rescue services provide highly trained personnel who administer care at the scene of the accident, and who are in radio contact with the hospital emergency department.
5. Have present a staff member trained in first aid to render care initially and to decide: (a) if the injured diver should be transported to a physician's office, minor emergency walk-in clinic or to a hospital emergency department, (b) whether transportation should be by private vehicle or ambulance.
6. Have transportation for getting to the selected medical facility available and designated prior to the activity.
7. If the decision is made to transport to a physician's office, notify the physician to ascertain whether he/she is available to see the injured diver.
8. Notify parents or guardian(s) of the diver's injury. The names and phone numbers of parents or guardians should be immediately available on the diver's file information card. Most state laws require that parents' or guardians' consent be obtained before physicians or emergency departments will administer treatment to minors. This consent procedure usually requires the parent or guardian be present at the treating facility or to sign the admitting form. However, each diver can have a consent for medical treatment form (Addendum 10) signed by the parents or guardians. Also, in an emergency, this consent may be given by parents or guardians by phone. In a catastrophic emergency, two other procedures can be used to obtain consent: (a) the emergency department

can call a local judge, who, when informed of the possible threat to the diver's life or limb, may give legal consent in the place of the consent of the parent or guardian, (b) if the diver is in danger of death, paralysis, in a coma or other life threatening situation, the emergency physician can use the doctrine of "implied consent." This infers that the parents/guardians or judge would consent if there were time to get in contact with them.

The reasonably prudent coach should not delay medical treatment due to inability to contact parents or guardians. Physicians in emergency departments have a great deal of experience in this area and can make all these calls from their office or emergency department.

**Access to the phone is vital.** Emergency information should be posted by the pool phone indicating where to call and in what order. Emergency information should be obtained immediately upon arrival at an away pool.

## **POLICIES AND PROCEDURES MANUAL**

A policy and procedure manual provides: (1) a reference for the facility staff, assistant coaches, parents/guardians/chaperones, (2) policies and procedures others can carry out in your absence, (3) written documentation in legal matters.

The policy and procedure manual may be kept in a three-ring notebook so pages can be added or deleted as policies and procedures change. All materials should be dated as they are added. The policy and procedure manual should be in two parts in which policy should be separated from procedure. The manual should be periodically reviewed and updated as needed.

Policies should designate the overall plans, general goals and leadership responsibilities. It should indicate who is responsible for which activity and when. There should be specific team and pool policies.

Procedures should designate specific steps to be followed in a definite order. The procedural part of the manual should include: (1) the emergency plan as previously outlined; (2) specific procedures for common injuries. This should include how you take care of a sprain, how you take care of an abrasion, how you take care of a laceration, etc., and (3) list of first aid supplies (a duplicate copy of the list should also be kept with the first aid equipment).

The facility where you coach may already have a policies and procedures manual. Check with the aquatics director and request a copy for your use. If the existing manual does not include information directly related to your diving program, you may wish to develop one of your own. A policies and procedures manual is, in essence, a safety manual. By having safety policies in writing, information is easily shared with other staff and participants. The following is an example of what could be included in a policies and procedures manual:

### **Policies**

Introduction

Aquatics Director's responsibilities

Diving Coach's responsibilities

Assistant Coach's responsibilities

Lifeguards' responsibilities  
U. S. Diving Athlete Registration Form  
Preparticipation Screening Form  
Program orientation procedures  
**Identification of potential hazardous areas, equipment, and activities**  
Records and reports

### **Procedures**

Emergency Action Plan  
**Chain of command for facility and program**  
Rules and regulations  
Legal responsibilities  
Disciplinary guidelines  
Reasons for dismissal from the diving program  
Appeal for reinstatement procedure  
**Pool security**

The intent of the policies and procedures manual should be to provide an instrument which will give guidelines to all individuals affiliated with the administration of the diving program. **This manual will also clarify duties and responsibilities of all individuals involved in the diving program** which, in turn, will provide a safer facility and environment. Follow the safety guidelines and risk management plans established by the program administrator.

## **CONTENTS OF FIRST AID KITS**

For a more detailed discussion of first aid kits, refer to the American Red Cross Sport Safety Training Handbook pp. ix-xi. For information on the how to use the contents of the first aid kit to care for the injuries listed below, refer to the page numbers provided in the American Red Cross Sport Safety Training Handbook). In addition, refer to the American Red Cross Sport Safety Training Workbook for procedures related to the application of dressings and control of bleeding (pp. 52-53), splinting (pp. 65-71, pp. 74-75), and applying a sling (pp. 72-73). The following items may be included in your diving first aid kit to care for:

1. Eye injuries. (*Handbook-p. 119*) (a) flashlight, (b) irrigating solution, (c) eye patches, (d) Q-tips, and (e) tape.
2. Ear injuries. (*Handbook-p. 117*) (a) cotton balls, (b) flashlight.
3. Lacerations and abrasions. (*Handbook p. 172*) (a) Betadine solution or hydrogen peroxide, (b) liquid soap, (c) antibiotic ointment, (d) heavy duty scissors, (e) sterile dressings: 2 x 2's & 4 x 4's (gauze pads), and (f) tape.
4. Bone, joint, and muscle injuries. (*Handbook p. 88*) (a) ice packs: chemical or baggies with closures to put ice in, (b) ace bandages – 2, 3, 4 & 6 inch widths, (c) splints for upper and lower extremities, (d) aluminum foam-covered splints for fingers, (e) slings for upper extremities with safety pins, and (f) one pair of adjustable crutches.
5. Miscellaneous. (a) notebook and pen to record care, (b) multipurpose knife, (c) tongue blades, (d) contact lens remover,

(e) contact lens solution for hard and soft lenses, (f) extra contact lens carrying case, (g) hand mirror, (h) aspirin, Tylenol, ibuprofen, (i) Vaseline, (j) Maalox or Mylanta tablets, (k) thermometer.

Although the following items for serious injuries (to protect the skull and spinal cord) will not fit in a kit, they should be provided by the home pool:

- (a) a long backboard (approximately six feet long and eighteen inches wide) with four straps or cravats used to secure the diver to the backboard or a vacuum mattress,
- (b) cervical collar(s) (stiff collars provide more support than soft collars) are used to keep the diver from bending his/her neck forward and backward. Cervical collars are available in a number of sizes, (c) equipment to prevent the diver from turning the head from side to side – i.e. a cervical immobilization device or rolled towels placed on both sides of the diver's head.

## **EAP POST-INJURY FOLLOW-UP**

There are a number of responsibilities the coach must assume following an injury to a diver. After the diver is injured, an accident or incident report form should be completed. U.S. Diving coach members should also file the U.S. Diving Injury Surveillance Questionnaire. In addition, the chain-of-command should be notified, as well as the victim's relatives. A follow-up report should be made if the diver suffered a severe injury requiring hospitalization. Another issue which will be addressed includes posttraumatic stress for the victim, the coach, and other individuals present during the injury.

## **ACCIDENT/INCIDENT REPORTS**

As a professional, you are responsible for completing an accident/incident report following an emergency. Completing such reports is often the only way to substantiate your procedures and actions if they are ever questioned. Complete the reports carefully as soon after the emergency as possible. Accuracy is essential. An accident report (p.24) is used any time first aid is required; an incident report (p.25) is used for any other situation, usually one in which a lifeguard, staff member, or outside agency is called into action.

Use this form as a guide; amend it to meet the unique needs of your facility.

The following information should be provided:

- Names, titles, employment numbers and years of experience of employees involved.
- Time, location and nature of the accident.
- Number of persons involved in the accident.
- Water and weather conditions.
- Number of divers present at the practice or competitive sessions.
- General comments of importance in evaluating the situation.
- Plan or sketch of the area showing any unusual conditions.
- Names, addresses and phone numbers of witnesses to the accident.

These questions should also be answered:

- How did the diving coach become aware of the accident?
- How soon did the diving coach respond to the emergency?
- What did the diving coach do in response to the emergency?

- Did the coach of another participant have to enter the water to effect a rescue?
- How far did the rescuer have to swim?
- What action did the coach take to help the victim?
- What rescue equipment was used by the coach?
- What did the coach observe about the victim's condition?
- Did the coach need assistance with the rescue?
- Did anything interfere with the rescue?
- Did the coach do everything possible to help revive the victim?
- What were the factors contributing to the accident?
  - What was the diver doing at the time of distress?
  - Had the diver disregarded rules, protocol or orders given by the coach?
- What first aid was administered?
- Was CPR necessary?
- Were police, emergency squad and ambulance called? At what time?
  - How soon did they respond?
  - What action did they take?
  - Was rescue breathing continued? By whom?
  - When did the EMS personnel or doctor take over?
  - When did the EMS personnel or doctor make a declaration of the victim's condition?
  - Was the victim removed from the pool area? When?

## Informing the Chain of Command

Once an accident has occurred, certain individuals need to be notified of the situation. The facility in use may currently have a list of people who need to be notified. If not, the coach should establish a list of individuals who need to have details relating to the accident. Information about the accident is essential not only for the coach, but for others involved with the diving program or diving facility. These individuals include: local diving club committee, assistant coaches, and facility personnel (lifeguards, pool manager, aquatics director, pool owner, pool maintenance). The diving coach should know who is included in the chain-of-command for the facility.

If proper communication is disseminated, there will be consistency in the information given out to the media, police, relatives and others. One person should be designated as the contact person for information relating to the accident. All others should be instructed not to talk to anyone. Refer them to the designated person and instruct them to talk only to the police about the accident. Part of the follow-up process is to guarantee privacy for the injured diver and to control rumors.

## Informing Relatives

Part of the emergency action plan established for the diving program should include contacting the parents or guardians of the injured diver. Parents should be notified immediately following the administration of first aid treatment. If the injury is severe and the coach is attending to the injury until EMS arrives, the parents should be notified as soon as possible after EMS assumes control of treatment. If other supervisors are available, the coach can designate someone to call the parents. Information given to the parents will vary according to the severity of the injury. The following information will be helpful to the parents:

- Give your name
- Explain that there has been an accident

- Give a brief explanation of the accident
- Inform them of who was contacted (EMS, doctor, hospital)
- Identify the hospital where the diver was taken
- Give the phone number where the diving coach can be contacted

Answer any additional questions the parents may have about the accident. The coach should have emergency information concerning the diver. It would be helpful to contact the diver's personal physician if possible.

## Hospital Follow-up

The diving coach should contact the medical facility where the injured diver is transported. If the coach arrives at the hospital with the injured diver, the coach should act as a parent in residence. In other words, do what a parent would do for the athlete. This may involve comforting the athlete or being present while the athlete is being cared for prior to the arrival of the parents.

Along with providing helpful information about the mechanism of the injury and progression of symptoms, the coach may be able to obtain additional helpful information about the injury by contacting the emergency care facility. The more information available to the coach, the easier it will be to answer questions regarding the accident.

Make certain the injured diver has transportation to his or her residence after treatment at the medical facility. Medications given to the injured diver may present some risks for the diver if adequate transportation home is not provided.

If the injured diver has a prolonged stay at a medical facility, it is advisable for the coach to visit the diver and consult with the attending physician to determine the extent of the injuries. The physician may be able to predict the length of recovery from the injury, and may also be able to identify activities which should be avoided during recovery.

## Posttraumatic Stress

In situations of severe injury, posttraumatic stress is a possibility not only for the injured diver but for others who may have been present during the emergency. Psychological trauma occurs in the wake of an unexpected event that a person has experienced intimately and forcefully. The more intense the person's experience of the event, the greater may be the trauma. There can be many degrees of trauma, from mild to severe. A posttraumatic stress response is a normal adaptive process of reaction to an abnormal situation. A specific event in a person's life may or may not produce a traumatic effect.

Traumatic events in competitive diving may include having a severe injury or witnessing a severe injury. There can be a variety of responses to this type of stress. The victim may have no memory of the event. Some may eventually remember what happened, while others may never remember. Losing a segment of time is very frightening for most people. They may require help in accepting this kind of loss. Others may be relieved to have no conscious memory of the event.

The traumatized individual may experience a variety of responses to the incident. Trauma responses may include:

## **Recurrent Distressing Emotions and Memories**

- Attacks of anxious arousal
- Fear of losing control over impulses and drives
- Fear that painful intrusive elements of trauma will not cease
- Fear that grief will result in ceaseless crying and uncontrollable emotional turbulence
- Fear of total breakdown
- Guilt over specific actions done during the event
- Anger/rage toward authorities, persons and institutions
- Guilt over presumed lost opportunity to effect a less tragic outcome

## **Recurrent Distressing Dreams**

- These are best described as “dreams of incomplete, unconsummated action”
- Symptoms, reactions and themes pertaining to traumatic dreams:
  - Inability to complete an important action that would facilitate survival at the moment
  - Sense of being fettered and totally frozen by fear and catastrophic expectations
  - Sense of vulnerability
  - Self as victim of dangerous, menacing forces with intent to do harm
  - Unable to escape from menacing pursuit
- Dissociation: illusions, hallucinations and flashbacks
  - Characteristics of dissociation: Inner sense of fragmentation –things crumbling or falling apart
  - Walled-off fear and rage
- Sleep disorders: inability to fall asleep
- Irritability and outbursts of aggression
- Self-blame

Some of the signs and symptoms the coach may observe include:

- Undue, prolonged anxiety; state of constant tension and fear
- Prolonged or severe depression
  - feelings of inadequacy, helplessness, hopelessness, undue pessimism and loss of confidence
  - Changes in behavior patterns
  - Withdrawal from friends, from loved ones, and from the usual occupations and hobbies that give pleasure
  - Low energy, chronic fatigue, decreased effectiveness at practice
- Abrupt changes in mood and behavior
  - Serious alterations in an individual’s normal habits or ways of thinking
- Tension-caused physical symptoms
  - Daily headache
  - A migraine induced by tension
  - Nausea

As a diving coach, how do you handle your athletes’ trauma?

- Recognize that it exists
  - Organize a plan for dealing with the possibility
  - Make it a part of your “Emergency Action Plan”
  - Include other professionals in its development
- Individuals look to their supervisors for support and assistance when traumatic situations occur
  - A sensitive approach by you can become a major force in how swiftly and thoroughly the athlete will recover
  - Coaches who take an overly defensive, aloof or adversarial position can make the situation far worse
  - Most traumatized athletes can return to proper functioning if they are treated reasonably
- Seldom are coaches given thorough training in what specifically to do:
  - Outside consultants could be used to train coaches
  - These consultants could be made available to the diving club if a traumatic event actually occurs
- After a traumatic incident emotions may run the gamut from numbness to terror or rage

- Those directly involved in the event are probably in a state of shock or emotional paralysis
- Those less directly involved may display their anger more freely
- In time, the anger of those immediately involved will emerge (who’s responsible for what happened?)
- There is often an impulse on the part of the athlete to think that their coach is somehow responsible for what happened.

Now that you can identify posttraumatic stress, what should be the coaches’ immediate response to the traumatic situation?

- Oversee the Emergency Action Plan
- Close the facility until personnel are prepared to provide proper supervision
- Debrief other divers and coaches
- Provide nonjudgmental moral support to others directly involved
- Follow-up with phone calls to athletes and coaches

There are other steps which could be taken to facilitate stabilization and recovery.

- Time could be set aside for athletes and coaches to discuss and work through their reactions to the event
- Athletes should be encouraged, not forced, to participate (have separate discussions with those directly and indirectly involved)
- Have professional facilitation for discussions
- If a traumatized athlete refuses to participate in discussion groups:
  - Approach him/her privately
  - Bring attention to the symptoms of trauma
  - Let him/her know you can refer them to an individual counselor
- Show genuine concern
- Others witnessing the traumatic event should be invited to participate in the counseling program
- After the traumatic incident, the coach should give athletes as much factual information as possible about the incident as well as conditions of the injured party (this avoids misinformation)

Posttraumatic stress can be devastating. A catastrophic injury in the sport of diving could create a distressing atmosphere. The coach needs to recognize the possibility of this occurring and take the necessary steps to anticipate the situation. This may include professional help for all individuals involved in or observing the injury.

## **INCLEMENT WEATHER**

Diving coaches at outdoor facilities should be alert to changes in local weather that require a change in workout plans. Post the number of a local weather reporting bureau along with other emergency telephone numbers. Each Emergency Action Plan should provide written guidelines for handling inclement weather, including responses to lightning and thunder. A local weather bureau may have advice about the frequency, duration and speed of storms in your area that might be useful in establishing policies for clearing the pool.

### **Weather Signs**

- Clouds that are high and hazy and form a halo around the sun indicate the arrival of a storm within hours
- Large clouds with cauliflower-like tops indicate a thunderstorm
- Rolling dark clouds indicate that bad weather will arrive within minutes

## Clearing the Pool

Precautionary measures should be taken if lightning is observed. You may estimate the distance to the storm when lightning is seen by counting the number of seconds before thunder is heard. Divide the seconds by 5. The result is the number of miles the storm is away.

The speed at which storms travel will vary. Observe the speed of the approaching storm and follow these guidelines for clearing the pool:

### *Fast-moving storm*

Clear the pool at the first sound of thunder.

### *Slow-moving storm*

Clear the pool when the storm is approximately 15 minutes away.

## Procedures for Clearing the Pool

1. Lifeguard gives one long blast on the whistle
2. Direct class to shelter
3. Stay away from diving boards
4. Stay away from metal pipes, metal railings, wire fences or other metal objects
5. Coaches/lifeguards should not stay in lifeguard stand
6. Do not stay under sheltered overhang next to the locker room entrances
7. Allow patrons to enter the water 15 minutes after the last sign or sound of the storm

## Heavy Rain or Hail

Heavy rain may obscure clear vision of the bottom. Clear the pool if a 6 inch black disk cannot be seen on the bottom at the deepest part of the pool.

Hail can be extremely dangerous to the well-being of the patrons and lifeguard. Clear the pool and direct patrons to a sheltered area.

## Tornadoes or High Winds

A “tornado watch” indicates that tornadoes and thunderstorms are possible. Observe the storm conditions and if wind obscures clear vision of the pool, clear the pool. A 6 inch black disk must be clearly visible in the deepest part of the diving pool.

A “tornado warning” means that a tornado has been sighted and that people should take shelter immediately.

1. Stay away from all windows, doors and outside walls.
2. Go to the basement of the building or to the interior parts at the lowest level.

## SUMMARY

Well thought out emergency action plans enable diving coaches to respond appropriately in the case of emergencies, meet the expectations of the head coach, pool manager or other administrators, and coach efficiently and effectively. The process of post-injury follow-up involves many things. The coach must be aware of the legal duties required and the

logical and appropriate reactions to an emergency. The accident or incident report will act as a record of the events occurring during the response to any injury. Informing the chain-of-command will assist in reducing confusion relating to the sequence of events during the emergency. A critical aspect of maintaining good relations with family members is to be professional and expedient in your approach to contacting them, and informing them of the accident. A hospital follow-up will demonstrate a caring attitude and will also be informative regarding the extent of the injury. Follow-up can also help prevent subsequent injuries or injuries to others.

## REFERENCES

- American Red Cross (1996) Safety Training for Swim Coaches. St. Louis, MO: Mosby Lifeline, pp. 23-24.
- American Red Cross (1997) Sport Safety Training Workbook, St. Louis, MO: Mosby Lifeline.
- American Red Cross (1992) Swimming and Diving. St. Louis, MO: Mosby Yearbook Publishers.
- Gabriel JL (1992) Diving Safety, A Position Paper. Indianapolis, IN: U. S. Diving Publications. p. 19.
- Gabrielsen M, Spivey M (1990) Diving Injuries: The Etiology of 486 Case Studies with Recommendations for Needed Action. Fort Lauderdale: FL Nova University Press. pp.8-9.
- Gruber F (1990) Emergency care. In Gabriel JL and George GS (eds.): U. S. Diving Safety Manual. Indianapolis, IN: U.S. Diving Publications, pp.19-26.
- Hoerner E. (1985) Medical responsibilities in gymnastics. In George GS (ed.): USGF Gymnastics Safety Manual. Indianapolis, IN: The USGF Publications Department, pp. 21-31.
- Micheli LJ, Jenkins M (1990) Sportswise. Houghton Mifflin Co., pp 145-155.
- Nygaard G, Boone TH (1985) Coaches Guide to Sport Law. Champaign, IL: Human Kinetics Publishing, pp. 24-25.
- Preparticipation Physical Evaluation (1992) American Academy of Family Physicians, American Academy of Pediatrics, American Medical Society for Sports Medicine, American Orthopaedic Society for Sports Medicine, American Osteopathic Academy of Sports Medicine.
- Preparticipation Physical Exams Fact Sheet. Available from the National Youth Sports Safety Foundation, Inc., 333 Longwood Avenue, Suite 202, Boston, MA 02115 617/277-1171

# Part 2. Practice Plans

by Janet L. Gabriel, M.A.

Planning enables a coach to carry out his/her coaching responsibilities and effectively manage time with the divers. The coach must take into consideration both dryland and pool activities in designing a diving program. Program plans should focus on performance outcomes in the following areas:

- fitness (*strength/power, flexibility, endurance, body composition and skill*),
- cognitive (*knowledge of rules and regulations*) and
- personal/social (*life skills*).

Season or, in the case of a diving lessons program, session plans provide an overview of program objectives and sequence of progression for introducing, reviewing and mastering skills. Lesson plans provide the details involved in implementing one lesson or training unit customized to be delivered appropriately for the age and skill level of the divers.

### Season Plan Development

1. Identify objectives focussing on physical, cognitive and social/personal outcomes. Physical skill categories may include the armswing, approach (forward/backward), take-off, connection (sequential transfer of momentum), flight position, comeouts, entries, basic dives, somersaulting dives, twisting dives, conditioning and flexibility (See page 26).

2. Sequence the objectives into pre, early, mid and late portions of the season (See Table 1). Identify prerequisites such as swimming competency for beginners. Preseason skills are usually related to readiness or fitness maintenance.

Early season objectives focus on core skill mastery and fitness goals in addition to logistical, organization concerns, safety orientation, discipline, socialization, competition rules and facility rules. The backward chaining method is a variation of the part teaching method whereby the sequence in which a skill complex is learned is reversed. For example, although landing and entry skills are the last skills in the sequence of a dive or dryland skill progression, they should be mastered first. At all levels, forward and reverse dives performed in competition with an approach may be introduced and refined using jumping drills in the early portion of the season. Controlled jumping take-off drills enable the coach and diver to emphasize the proper loading of the board during take-off and attend to the coordination of the squat, armswing, springboard depression and recoil.

Mid season objectives focus on introducing new skills, refining skills, combining subskills into whole dives and integrating an approach with the whole dive. In general the

emphasis is on the gradual improvement in proficiency and consistency of individual dives. Emphasis continues on cognitive, fitness and personal/social objectives.

Late season objectives focus on maintaining conditioning and flexibility levels and emphasis on skill development competition or performing dive lists. A greater portion of practice time should be spent on performing the skill development complex or competition list in dive order for a score.

3. Specify the objectives of each practice. Select objectives that are essential to your diver's age and skill level. A season calendar can be used to synthesize your decision making onto a master session or season planning calendar (see Table 2. Sample Session Planner).

4. Identify the time allotment for achievement of the objectives. Once introduced the cognitive and social/personal objectives are often times refined ongoing throughout the season and are generally integrated with the practice of the physical skills and participation in competition. To maximize the time available, assign a high priority to skills with the most transfer of learning. Allow time to:

- assess the diver's readiness
- introduce the skill objective
- teach the critical elements of the skill
- improve proficiency and consistency



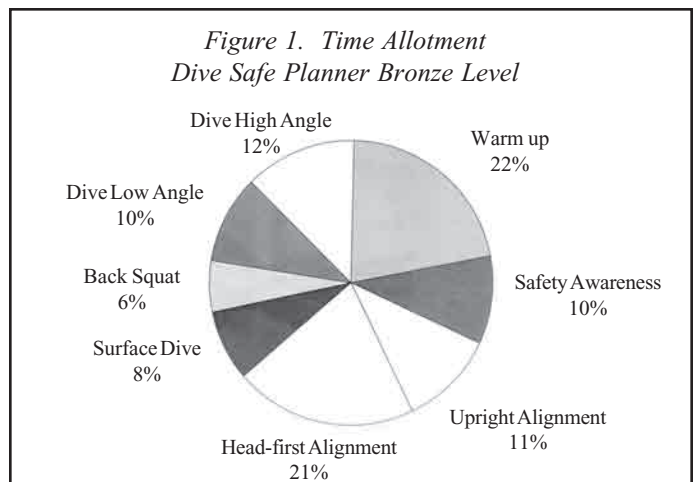





Teaching beginners to enter the water safely is the goal of the bronze level of the U.S. Diving Dive Safe program. In Figure 1. Time Allotment, about ninety percent of the lesson time including much of the warmup is spent working on movements and skills directly related to safety awareness, alignment and head-first dive progressions.



**Table 1. Performance Objectives (I=Introduce, R=Review, M=Master)****U.S. Diving: Dive Safe Bronze Level***Prerequisite = Demonstrate 25 yards swimming endurance and breath control.*

<b>OBJECTIVES</b>	(Lessons 1-3)	(Lessons 4-6)	(Lessons 7-8)
	<b>EARLY</b>	<b>MID</b>	<b>LATE</b>
<b>Physical Conditioning and Flexibility</b>			
<b>1. Warm up Activities</b>	<b>I</b>	<b>R</b>	<b>M</b>
Continuous movement to raise core body temperature to appropriate readiness and maintain throughout remaining practice session			
Increase muscle strength to hold entries, squat deep, jump high and point toes.			
Increase flexibility to reach arms over the ear, elevate shoulders, squat with heels down, stretch instep and point toes.			
<b>Cognitive Knowledge</b>			
<b>2. Diving Safety Awareness</b>	I/R	I/R	R
Identify the primary safety objectives in both competitive diving and recreational water entry activities.			
Define shallow, mid-range and deep water.			
Know FINA competitive depth for 1-meter springboard			
Recognize depth markings in pools, "NO DIVING" and restricted access signs and barricades			
Demonstrate appropriate first-time water entry strategies (i.e. "ease in", "walk in", jump off diving board.			
Recognize the breakpoint of the upslope.			
Demonstrate ladder climbing skills.			
Identify "No Diving" situations			
<b>Physical Skills</b>			
<b>3. Up right body alignment</b>	I	I/R	M
Demonstrate proper upright alignment in the static starting position (i.e. pelvis and rib cage control).			
Demonstrate proper upright alignment under dynamic conditions (i.e. feet-first entry).			
<b>4. Head-first Entry alignment</b>	I	I/R	M
Align the body with the arms overhead (shoulder stability) and hands grabbed to protect the head, neck and spine on head-first entries.			
Align the upper and lower body to enhance rigidity.			
Tighten muscles to enhance rigidity on head-first entries.			
<b>5. Surface Dive with Roll Underwater</b>	I	R	M
Disrupt the preexisting righting reflex that produces a belly flop by substituting an antagonistic movement by demonstrating skill mastery of surface dive with roll.			
Demonstrate breath control.			
Demonstrate underwater orientation.			
<b>6. Back squat</b>	I	R	M
Demonstrate proper form throughout the squat.			
Demonstrate the ability to focus on a fixed spot.			
Squat with the feet flat on the ground.			
Maintain the trunk as upright as possible throughout the squat.			
<b>7. Low angle recreational dive</b>	I	R	M
Demonstrate proper head position at entry.			
Demonstrate competitive diving hand grabbing technique to protect the head, neck and spine during head-first entry.			
Demonstrate the recreational water entry with 1) a low angle takeoff, 2) near horizontal entry and 3) steer up.			
<b>8. High angle competitive dive</b>		I/R	R
Demonstrate proper head position at entry.			
Demonstrate competitive diving hand grabbing technique to protect the head, neck and spine during head-first entry.			
Demonstrate the competitive diving water entry with 1) a high angle take-off, 2) near vertical entry, and 3) a roll underwater.			
<b>Personal/Social</b>			
9.	Enjoyment of diving activity		
10.	Show self confidence through participation in diving		
11.	Meet new friends		
12.	Be part of a team in an Olympic sport		
13.	Practice good sportsmanship by respecting the rights of others		
14.	Listen to directions		
15.	Attentional control-stay on task		
16.	Accept criticism		
17.	Take turns fairly		
18.	Cooperate voluntarily to follow rules		
19.	Assume limited leadership responsibility		
20.	Ask for help when need arises		

Table 2. Sample Session Planner  
U.S. Diving Dive Safe: Bronze Level

Lesson	Warm Up	Safety Awareness	Upright Alignment	Headfirst Alignment	Surface Dive	Back Squat	Dive Low Angle	Dive High Angle
								
1 45 min	10 min Continuous- 4min Strength- 3 min Flexibility-3 min	5 min Objectives First time entry Pool Rules	5 min Static pelvis rock lie supine, knees bent Dynamic-walk Feet first step off PS	15 min Hand grab technique Stand F & B hollow Stability & rigidity check F slide in on stack mat- PS	10 min Surface glide Glide to bottom Stand glide to bottom Surface Dive with roll	5 min Stride leg Take-off		
2 45 min	10 min Continuous- 4 min Strength- 3 min Flexibility-3 min	5 min Review Lesson #1 Recognition- signage & water depth	5 min Standing push & pull Dynamic-quickly assume alignment Feet-first step off 1m	15 min F slide in on stack mat 1m B slide in on stack mat-PS Leg adduction drill F & B hollow-balance	5 min Surface dive tuck toes pointed with roll Back push & glide with follow through			
3 45 min	10 min Choose 3 exercise leaders Review Lesson #2	4 min Review Lesson #2 Walk in test water depth over the head	4 min Squat & jump-upper body in head-first entry alignment deck & PS	10 min F & B slide in-1m Dynamic rigidity prone & supine leg lifts Instep stretch	2 min Surface dive pike toes pointed with roll Review back push & glide with follow through	5 min Introduce back squat perform slowly with proper form	10 min Low angle dive from a squat, glide to bottom Repeat for distance Repeat- begin freestyle	
4 45 min	10 min Choose 3 exercise leaders Review Lesson #3	2 min Review Lesson #3 No diving situations	5 min Assume forward entry position, squat and jump high, hold upright alignment 1m	5 min Static rigidity supine hold B hollow; prone hold F hollow Dynamic rigidity-log roll	1 min Review surface dive pike toes pointed with roll and Back push & glide with follow through	2 min Review Lesson #3 Perform 8-12 reps	10 min Underwater (UW) glide UW glide with steer up Low angle dive from squat with steer up PS	10 min High angle take-off from squat, no armswing through hula hoop with roll
5 45 min	10 min Choose 3 exercise leaders Review Lesson #4	5 min Review Lesson #4 Surface dive deep to breakpoint & upslope	5 min Upright jump body in head-first entry alignment PS	10 min Review F&B slide in 1m Dynamic-handstand walk up wall, hand walk Hand support toe pt	1 min Review surface dive pike toes pointed with roll and follow through	2 min Review Lesson #4		12 min High angle take-off upright, no armswing through hula hoop with roll
6 45 min	10 min Choose 3 exercise leaders Review Lesson #5	5 min Review Lesson #5 Ladder climbing up and down	5 min Upright jump body in head first entry alignment 1m	10 min Review F & B slide in 1m Static-Kick handstand Hold armstand back hollow	2 min Review Lesson #5			13 min High angle take-off upright, no armswing through hula hoop to hand stand on bottom
7 45 min	10 min Divide class into 3 groups. Each group leads one of three parts of the warm up	5 min Ladder climbing and feet first step off 3m (optional)	5 min Upright jump for height with arms overhead & hands grabbed 1m	5 min Forward & Backward slide on stack mat 1m	5 min Review surface dive pike with toes pointed	5 min Review Lesson #6	5 min Unassisted low angle take- off with near horizontal entry and steer up	5 min High angle take-off upright, no armswing through hula hoop to hand stand on bottom
8 45 min	10 min Divide class into 3 groups. Each group leads one of three parts of the warm up	5 min Ladder climbing and feet first step off 3m (optional)	5 min Upright jump for height with arms overhead & hands grabbed 1m	5 min Forward & Backward slide on stack mat 1m	5 min Unassisted surface dive pike with toes pointed	5 min Unassisted single back squat with proper form	5 min Unassisted low angle take- off with near horizontal entry and steer up	5 min Unassisted high angle take off upright with near vertical entry and glide towards bottom
360 min	80 min	36 min	39 min	75 min	29 min	21 min	35 min	45 min

## Warm Up

The conditioning and flexibility plans for a lessons program may be addressed in the warm up. Warm up is scheduled prior to the skill training to prepare the diver for the demands of the skill training. A 10-minute warm-up may begin with four minutes of continuous movement such as brisk walking, easy jogging, skipping rope, aerobic dance movements, walking/jogging stairs, and/or swimming. The continuous movement may be followed by three minutes of conditioning exercises using vigorous gross motor movements and may conclude with three minutes of light stretching

through a variety of motions in specific joints (see Table 3. Session Planner Sample Warm Up).















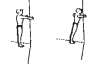

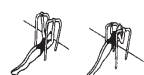

## Post Skill Training

As divers in a lessons program progress into team situations, coaches may implement conditioning and flexibility training sessions following the physical skill training session. The purpose of these post skill training sessions is to enhance strength/power and increase range of motion related to the demands of the sport (see pp. 131-134 for resistance and flexibility training guidelines).

Session: 4 wks (2 lessons/wk)

**Table 3. Session Planner Sample Warm up**  
U.S. Diving Dive Safe: Bronze Level

Divers' Age Group 5-6 yrs

	Conditioning Exercise	Sets	Duration	Flexibility Exercise	# of Reps	Repetition Duration	Exercise Duration
1	 Squat jump and vertical jump (Burpies)	1	20 seconds	 Neck forward 1/2 circles	1 x 2 sides	5 seconds	10 seconds
2	 Push ups/bent knee wall/table bounds	1	20 seconds	 Pectoralis	1	10 seconds	10 seconds
3	 Walking lunges	1	20 seconds	 Press up	1	10 seconds	10 seconds
4	 Armstand lead up	1	20 seconds	 Double knee to chest	1	10 seconds	10 seconds
5	 Closes	1	20 seconds	 Trunk & neck rotation	1 x 2 sides	10 seconds	20 seconds
6	 Ladder pull ups	1	20 seconds	 Hamstring stretch	2 x 2 sides	10 seconds	40 seconds
7	 Tuck kick outs	1	20 seconds	 Mid-back stretch	1	10 seconds	10 seconds
8	 Back extensions/ Arch ups	1	20 seconds	 Thoracic spine extension over chair	1	10 seconds	10 seconds
9	Repeat one exercise	1	20 seconds	 Ankle & calf stretch	2 x 2 sides	10 seconds	40 seconds
10				 Quadriceps stretch	1 x 2 sides	10 seconds	20 seconds
<b>Total</b>	8	9	3 min	10	10		3 min

## Lesson Plan Development

Written lesson plans provide documentation of planning. For standardization, some coaches find it useful to develop a template of the lesson plan format (see page 27). Practice plans answer the who, how and what questions related to your lessons and training sessions. Lesson plans should be designed to enable coaches to provide effective instruction based on the season planner. Lesson plans (see Table 4) identify:

- performance objectives
- time allotment
- practice methods (*activities to teach or practice the objectives*)
- performance cues
- equipment
- traffic control (*class organization*)
- training station

Lesson plans include warning prompts of risks inherent in the given skill or circumstances under which the skill will be performed.

The skills presented in the plan should be age-appropriate. In a sport like diving with a high skill component, lesson plans need to take into consideration readiness to perform the skills layered into the plan. Performer readiness and proper instruction issues are presented in Chapter VII and VIII.

Performer readiness, to perform a skill safely in a busy diving well, relates to traffic flow awareness. For the purposes of traffic control, beginning divers may need to be assigned a starting place on the mat or side of the pool to which they return after the completion of each trial. Divers should be spaced at least arms length apart in drills requiring armswings. Lines may also be staggered with every other diver moving forward or backward to create space for the armswing or other activity.

I-Introduce  
R-Refine/Review  
M-Master

**Table 4. Sample Plan Lesson 1  
USD Dive Safe Bronze**

DCK-Deck  
MAT-Basic, SMT-Stack Mat  
PS-Poolside, IMS-1-meter  
IMP-1-meter platform

MIN	I/R/M	OBJECTIVES	CUES	PRACTICE METHODS	TRAFFIC CONTROL	TRAINING STATION
<b>10 WARM UP</b>						
10	I	Aerobic, strength, flex	Name each exercise	Group activity	Space arms length apart	DCK/MAT
<b>5 UPRIGHT BODY ALIGNMENT</b>						
2	I	Pelvic rock	Hips Under- "Push" bottom of pelvis forward & up	Lie supine;knees bent	1 diver on a panel	MAT
2	I	Rib cage	Lift ribs & align back in a straight line	Coach adjusts alignment; If chest concave, place one hand on back, move ribs forward; If chest convex, place one hand on ribs, move ribs back to spine; Stabilize pelvis with other hand; Press palms toward each other	Stand sideways	DCK/MAT
1	I	Dynamic upright align	Walk tall	Group activity	Walk forward and return to start	
<b>10 HEAD-FIRST ENTRY ALIGNMENT-DRYLAND</b>						
3	I	Hand grab technique	Palms up	Group activity Coach checks individuals	Standing in place	DCK/MAT
3		Stability check	Shoulders to ears			
2		Forward hollow	Chest pike			
2		Backward hollow	Spread the curve			
3		Rigidity check	Press legs to midline Press shoulders to ears	Lie prone in head-first entry position; Coach pulls legs apart; diver resists and inserts a finger into space between ears and shoulder	Lying in place	
<b>5 SAFETY AWARENESS</b>						
1	I	Avoid hitting head	No diving in shallow water	Group activity	Sitting spaced arms length apart	PS
1	I	Pool rules	No running on deck etc			
1	I	Ease in/Wade in	<b>Warning!</b> Do not jump or dive to test water depth. Feet-first, 1st time in deep diving area.	Start at the same time on cue	Standing spaced arms length apart	
2		Feet first step off				
<b>10 SURFACE DIVE</b>						
2	I	Surface glide	Glide in entry position	Group activity	Spaced arms length apart holding onto side	Shoulder deep shallow water
2		Glide to bottom	Blow bubbles out nose			
2		Stand glide to bottom				
4		Surface dive with roll				
<b>5 HEAD-FIRST ENTRY ALIGNMENT-POOL</b>						
3	I	Forward Slide in	Hold your shape	Coach works individually with each diver	Perform surface dive and roll; return to line	PS-STK MAT

Equipment needed: MAT, STM

**Delivery**

Even well designed plans need to be executed reasonably and prudently. As discussed in Chapter V, coaches should know what equipment is used for various diving activities and plan accordingly. Proper matting and spotting must be provided for the activities, regardless of any spur of the moment changes made in the lesson plan. Traffic control is essential to avoid collisions with other divers and pool users.

**Evaluation**









Performance outcomes may be framed for individuals with respect to improved proficiency or consistency. Coaches may evaluate the divers' proficiency and consistency on physical skills, as well as achievements in knowledge, fitness, and personal/social skills (see Table 5). By evaluating the divers' performance outcomes on the planned objectives, coaches may gain insight into coaching effectiveness. Evaluation enables coaches to make changes to improve the program and its delivery.

Session \_\_\_\_\_

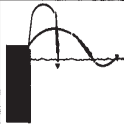
**Table 5. Score Card**  
U.S. Diving Dive Safe: Bronze Level

Date \_\_\_\_/\_\_\_\_/\_\_\_\_

Instructor \_\_\_\_\_

Diver	Warm Up	Safety Awareness	Upright Alignment	Headfirst Alignment	Surface Dive	Back Squat	Dive Low Angle	Dive High Angle	Pass/Retest
									P/R

GRADING SCALE    RETEST (R)    0 - 4.0  
                           PASS (P)        4.5 - 10

## **Skill mastery monitoring**

Skill acquisition of core and lead up skills takes time. Coaches of beginning and intermediate divers should prioritize skill mastery at each step of the skill progression over meet preparation (see page 102). Skill development competition encourages skill mastery of fundamental skills. Skill complexes of jumps, line-ups, forward and inward comeouts and back and reverse comeouts have been designed to test the junior diver's competency (see Official Rules of Diving & Code of Regulations of United States Diving). Once mastered, these skills provide divers the chance to perform their competition dives in a technically correct manner and at a high level of proficiency.

Monitoring divers' proficiency and consistency on dives and whole lists is an important aspect of competition preparation for advanced divers. A scoring form for monitoring proficiency and consistency of dives/skills and whole lists is available (see page 34).

## **Modification of lesson plans**

Diving coaches need built-in flexibility within every lesson plan to explore creative solutions for the group and/or individual divers. Proper instruction in diving includes being able to facilitate modifications in a movement pattern or technique for an individual diver on the spur of the moment. Sometimes the entire lesson plan will need to be altered after an initial assessment of the divers. For example the divers may be too fatigued from the conditioning program the previous day to execute the number of dives planned or to perform the number of dives planned from a given height. During the training session if a diver hits the board, lands flat on an entry, or is too close to the board on a given dive or dive group, the coach may have to alter the plan on the spot to provide for the safety of the diver. Assistant coaches should have lesson plans approved by the head coach. If circumstances require the lesson plan or activity to be modified, it should be done in a manner that does not jeopardize the safety of the diver.

## **Back up Plans**

Be sure to have a backup plan in the case of inclement weather. In some situations, the workout will have to be cancelled altogether or moved to an indoor classroom or pool if available. Be ready with alternative practice plans such as dry land training, viewing a video tape for analysis, or mental rehearsal.

## **SUMMARY**

Well thought out practice plans enable diving coaches to coach efficiently and effectively. Developing lesson plans and alternatives is a safeguard that enables the coach to fulfill legal responsibilities related to injury control. A detailed practice or lesson plan will help coaches make use of every second of valuable practice time. Evaluation of the diver's performance outcomes provides feedback on the program design and effectiveness of its delivery. In the event of a lawsuit, you may

be asked to produce your practice plans. Evaluate your plans and modify them as needed. Remember to retain your lesson plans.

## **REFERENCES**

- Brown EW (1992) Sample practice plans. In Seefeldt V, Brown EW (eds.): Program for Athletic Coaches' Education Reference Manual. Dubuque, IA: Brown & Benchmark, 18 pp 13-23.
- Gabriel JL, George GS, Kimball D, O'Brien R, Xie C (1995) Dive Safe. Indianapolis, IN: U.S. Diving Publications.
- Gabriel JL (1988) Diving Safety, A Position Paper. Indianapolis, IN: U. S. Diving Publications.
- Nygaard G, Boone TH (1985) Coaches Guide to Sport Law. Champaign, IL: Human Kinetics Publishing, pp. 24-25.
- O'Brien R (1998) Skill development competition. In Official Rules of Diving and Code of Regulationsof United States Diving. Indianapolis, IN: U.S. Diving Publications, pp. J:27-J:30.
- Vogel P (1992) Planning for the season. In Seefeldt V, Brown EW (eds.): Program for Athletic Coaches' Education Reference Manual. Dubuque, IA: Brown & Benchmark, 27 pp 1-13.



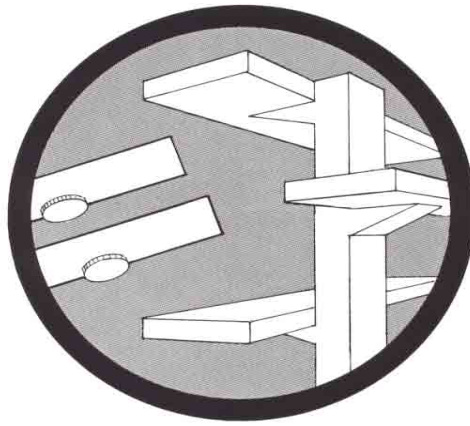

## **CHAPTER IV**

# **COMPETITIVE DIVING FACILITIES**

by D. Joe Hunsaker, B.S.

### **CHAPTER COMPETENCIES**

**Upon completion of this chapter, coaches should be able to:**

- *Know what diving pool dimensions are needed by divers and required by the appropriate rules governing competition and what is needed for injury control in practice.*
- *Know FINA and other appropriate governing bodies' dimensions related to diving boards, platforms, lighting, railings, ladders and stairs.*
- *Know how to inspect facilities for compliance with requirements.*
- *Inspect facilities for potential safety hazards prior to each use.*

Diving involves aerial heights and entry depth. FINA competitive diving dimensions are designed to provide the athlete room to maneuver safely in the air and under water. Although there is no record in the United States of a catastrophic diving injury from impact with the pool bottom in a diving area that meets competitive diving organization facility dimension recommendations, these dimensions are not fail-safe. What makes a competitive diving facility safe or unsafe is how it is used. Coaches need a basic understanding of these dimensions in order to use good judgement related to the safety of the athlete. A diving area should be designed and used in a manner that prevents the athlete from collision with the ceiling, other equipment, the pool side, pool walls, pool bottom (especially at the upslope), and other divers and swimmers.

## **FACILITY DIMENSIONS**

### **PLUMMET**

The basic reference for measurement of competitive diving dimensions is the plummet. The plummet is a vertical line extending through the center point of the front edge of the springboard or platform.

### **HOW TO USE THE DIMENSIONS**

Each event, springboard or platform, provides horizontal and vertical dimensions related to the levels of 1-meter, 3-meter, 5-meter, 7.5-meter and 10-meter for the twelve design variables A through N (see Figure 4.1). To read the table the coach should identify the intersection of the design variable and the event by level. For example:

**The recommended depth of water at the plummet (H) for competition under the 1-meter springboard is a minimum of 3.4 meters and the preferred depth is 3.5 meters.**

FINA dimensions are listed in meters. To convert from meters to feet, multiply the recommended dimensions in meters by 39.37 and divide by 12.

### **DIVING ENVELOPE ABOVE WATER SURFACE**

#### **(A-G)**

These dimensions are provided to prevent collisions with the ceiling or platforms and to prevent collisions with the pool walls, pool sides, other equipment and other pool users. The dimensions include:

- A-From plummet back to pool wall.
- A/A-From plummet back to platform plummet directly below
- B-From plummet to pool wall at side
- C-From plummet to adjacent plummet
- D-From plummet to pool wall ahead
- E-Board to ceiling at plummet
- F-Clear overhead behind and each side of plummet
- G-Clear overhead ahead of plummet

#### **A-From plummet back to pool wall**

This dimension has been established to dictate the length of the overhang of the springboard/platform beyond the wall below. For example, the preferred springboard overhang is 1.8 m (6 ft). The platform overhang depends on the height of the platform and ranges from .75 meters to 1.5 meters.

#### **AA-From plummet back to platform plummet directly below**

This dimension provides for the distance that a platform below should be behind the end of the platform above.

#### **B-From plummet to pool wall at side and C-From plummet to adjacent plummet**

These two categories, which relate to lateral dimension to the pool wall at the side and to the lateral dimension from one plummet to the adjacent plummet, dictate the necessary clearance to prevent a diver from making an error during a take-off resulting in impact with the side wall or with another diver using an adjacent springboard/platform. Special attention must be paid to the footnote in the rules regarding the change of these dimensions when the platform widths are greater than the minimums identified in the chart: If platform widths are increased, then C is to be increased by half the additional width(s).

#### **D-From plummet to pool wall ahead**

This dimension dictates the clearance between the end of the springboard/platform and the end of the pool. Competitive divers practicing and competing strive to jump vertically for height more than to broad jump for horizontal distance. For competitive use, dimension D is considerably overbuilt. The clearance is appropriate, however, in the event of unconventional take-offs involving running fast and jumping for distance.

#### **E-From plummet, on board to ceiling, F-Clear overhead behind and each side of plummet and G-Clear overhead ahead of plummet**

These dimensions refer to distance to the ceiling from the plummet above, behind, to the sides and ahead. All things being equal related to take-off, a diver who jumps higher on a dive will also travel out farther and have more flight time to complete the rotations. These dimensions are overbuilt to provide divers room to maneuver in the air without feeling as though he/she has to dampen the jump to avoid hitting the ceiling.

### **DIVING ENVELOPE BELOW WATER SURFACE**

#### **(H-N)**

These dimensions are provided to give adequate room to maneuver underwater to avoid collisions with the pool bottom, upslope and pool sides which could result in serious spinal cord injuries. Coaches should be aware that within practical limits of pool design, it is not possible to rely only on the

FINA Dimensions for Diving Facilities As of 3 March 1991 (See FR 5.3.1)		Springboard				Platform										
		1 Metre		3 Metres		1 Metre		3 Metres		5 Metres		7.5 Metres		10 Metres		
		LENGTH	WIDTH	HEIGHT	HORIZ	VERT	HORIZ	VERT	HORIZ	VERT	HORIZ	VERT	HORIZ	VERT	HORIZ	VERT
A	From plummet BACK TO POOL WALL	Designation	A-1	A-3	A-1 pl	A-3 pl	A-5	A-7.5	A-10							
		Minimum	1.50	1.50	0.75	1.25	1.25	1.50	1.50							
		Preferred	1.80	1.80	0.75	1.25	1.25	1.50	1.50							
A/A	From plummet BACK TO PLATFORM plummet directly below	Designation						A/A5/1	A/A/5/3,1	a/A10/5,3,1						
		Minimum						0.75	0.75	0.75						
		Preferred						1.25	1.25	1.25						
B	From plummet to POOL WALL AT SIDE	Designation	B-1	B-3	B-1 pl	B-3 pl	B-5	B-7.5	B-10							
		Minimum	2.50	3.50	2.30	2.80	3.25	4.25	5.25							
		Preferred	2.50	3.50	2.30	2.90	3.75	4.50	5.25							
C	From plummet to ADJACENT PLUMMET	Designation	C 1-1	C 3-3,3-1	C 1-1 pl	C 3-3 pl, 1 pl	C 5-3,5-1	C 7.5-5,3,1	C 10-7.5,5,3,1							
		Minimum	2.00	2.20	1.65	2.00	2.25	2.50	2.75							
		Preferred	2.40	2.60	1.95	2.10	2.50	2.50	2.75							
D	From plummet to POOL WALL AHEAD	Designation	D-1	D-3	D-1 pl	D-3 pl	D-5	D-7.5	D-10							
		Minimum	9.00	10.25	8.00	9.50	10.25	11.00	13.50							
		Preferred	9.00	10.25	8.00	9.50	10.25	11.00	13.50							
E	From plummet, on BOARD TO CEILING	Designation	E-1	E-3	E-1 pl	E-3 pl	E-5	E-7.5	E-10							
		Minimum	5.00	5.00	3.25	3.25	3.25	3.25	3.25	4.00						
		Preferred	5.00	5.00	3.50	3.50	3.50	3.50	3.50	5.00						
F	CLEAR OVERHEAD behind and each side of plummet	Designation	F-1	F-3	F-1 pl	F-3 pl	F-5	F-7.5	F-10							
		Minimum	2.50	5.00	2.50	2.75	3.25	2.75	3.25	2.75	4.00					
		Preferred	2.50	5.00	2.50	2.75	3.50	2.75	3.50	2.75	5.00					
G	CLEAR OVERHEAD ahead of plummet	Designation	G-1	G-3	G-1 pl	G-3 pl	G-5	G-7.5	G-10							
		Minimum	5.00	5.00	5.00	3.25	5.00	3.25	5.00	6.00	4.00					
		Preferred	5.00	5.00	5.00	3.50	5.00	3.50	5.00	6.00	5.00					
H	DEPTH OF WATER at plummet	Designation	H-1	H-3	H-1 pl	H-3 pl	H-5	H-7.5	H-10							
		Minimum	3.40	3.70	3.20	3.50	3.70	4.10	4.50							
		Preferred	3.50	3.80	3.30	3.60	3.80	4.50	5.00							
J K	DISTANCE AND DEPTH ahead of plummet	Designation	J-1	K-1	J-3	K-3	J-1 pl	K-1 pl	J-3 pl	K-3 pl	J-5	K-5	J-7.5	K-7.5	J-10	K-10
		Minimum	5.00	3.30	6.00	3.60	4.50	3.10	5.50	3.40	6.00	3.60	8.00	4.00	11.00	4.25
		Preferred	5.00	3.40	6.00	3.70	4.50	3.20	5.50	3.50	6.00	3.70	8.00	4.40	11.00	4.75
L M	DISTANCE AND DEPTH each side of plummet	Designation	L-1	M-1	L-3	M-3	L-1 pl	M-1 pl	L-3 pl	M-3 pl	L-5	M-5	L-7.5	M-7.5	L-10	M-10
		Minimum	1.50	3.30	2.00	3.60	1.40	3.10	1.80	3.40	3.00	3.60	3.75	4.00	4.50	4.25
		Preferred	2.00	3.40	2.50	3.70	1.90	3.20	2.30	3.50	3.50	3.70	4.50	4.40	5.25	4.75
N	MAXIMUM SLOPE TO REDUCE DIMENSIONS beyond full requirements	POOL DEPTH	30 degrees		NOTE: Dimensions C (plummet to adjacent plummet) apply to Platforms with widths as detailed. If Platform widths are increased then C is to be increased by half the additional width(s).											
		CEILINGHT	30 degrees													

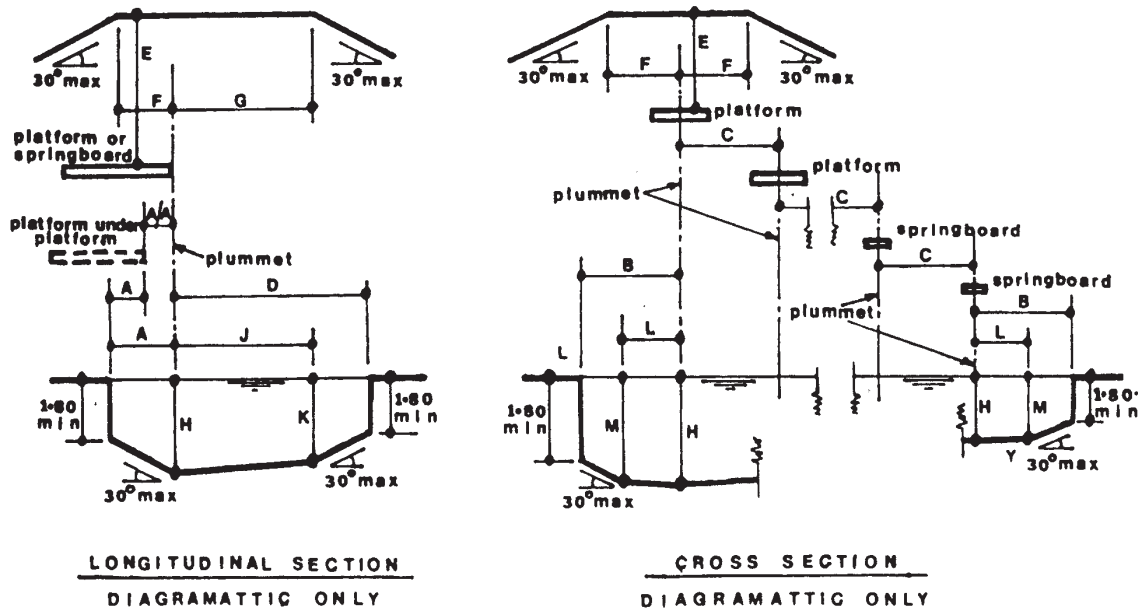

Figure 4.1 FINA Dimensions for Diving Facilities

slowing effect of the water to assure that the diver will not hit the bottom of the pool at dangerous velocities. There is a basic requirement that the diver steer underwater to avoid potentially injurious impact with the bottom of any practical pool. The dimensions include:

- H-Depth of water at plummet
- J/K-Distance and depth ahead of plummet**
- L/M-Distance and depth each side of plummet
- N-Maximum slope to reduce dimensions

### MAXIMUM SLOPE TO REDUCE DIMENSIONS

The maximum slope to reduce dimensions is 30 degrees until dimension A, B or D is obtained. For example on 1-meter springboard:

#### Pool wall ahead

Once J is reached 5 meters ahead of the plummet, the pool bottom may rise at a slope of 30° until dimension D is reached 9 meters ahead of the plummet where a vertical wall may be built.

#### Pool wall at side

Once L is reached 1.5 meters to the side of the plummet, the pool bottom may rise at a slope of 30° until dimension B is reached 2.5 meters to the side of the plummet, where a vertical wall may be built.

#### Back to pool wall

The pool bottom may rise at a slope of 30° until A is reached 1.5 meters behind the plummet, where a vertical wall may be built.

### STACKED PLATFORMS

The construction of stacked platforms is prevalent in the United States. In building stacked platforms, the architect must take into consideration dimension C-from plummet to adjacent plummet and dimension AA – the overhang.

### DIVER'S VISUAL PERCEPTION OF THE POOL

The sport of diving has a visual aspect related to safety and performance. Divers need to be able to see the board during approach, take-off and flight, and to see the water at entry.

#### Glare

In outdoor pools, springboards and platforms are to face north in the northern hemisphere to avoid glare related to the east to west path of the sun. Sources of illumination should prevent glare in order that a diver does not get blinded in a bright light. FINA Rule **FR 5.3.9** states: Mechanical surface agitation shall be installed under the diving facilities to aid the divers in their visual perception of the surface of the water.

### Lighting

Lighting must be sufficient to allow divers to view the water safely. **FR 5.3.7** The minimum illumination at a level of 1 meter above the water surface shall not be less than 600 lux. **FR 6.1** For the Olympic Games and World Championships, however, the light intensity at a level of one meter above the water surface shall not be less than 1500 lux.

### EQUIPMENT REGULATIONS

**FR 5.3.3** The height of the springboards and each platform above the water level may vary by plus 0.05 meters to minus 0.00 meter from the heights prescribed in the rules.

### SPRINGBOARDS

#### Size

The springboard shall be 20 inches wide and 16 feet long, and shall be covered along the whole length with an adequate nonskid material.

#### Overhang

The front edge of the board shall project at least five feet, and preferably six feet, beyond the edge of the pool.

### PLATFORMS

#### Size

**FR 5.2.1** Each platform shall be rigid. **FR 5.2.2** The minimum dimension of the platform shall be:

<u>Platform</u>	<u>Width</u>	<u>Length</u>
.6m to 1.0m	.6m	5.0m
2.6m to 3.0m	.6m (preferred 1.5m)	5.0m
5.0m	1.5m	6.0m
7.5m	1.5m	6.0m
10m	2.0m	6.0m

For synchronized diving events, the 10 meter platform should be at least 8 feet wide and preferably 10 feet wide. The surface and the front edge of the platform shall be covered with a resilient non-slip surface material approved by United States Diving, Inc.

#### Overhang

**FR 5.2.6** Where a platform is directly underneath another platform (AA), the platform above shall project a minimum of .75 m (preferred 1.25 m) beyond the platform below.

**FR 5.3.4** The end of the 5-meter platform may not project beyond the ends of the 3-meter springboards.

### SAFETY RAILS

#### Springboard

**U.S. Diving rule 101.2 (d).** It is recommended that 3-meter springboard stands be equipped with safe guard rails

that extend at least to the pool edge and will prevent divers from falling off the board onto the deck at the sides.

### **Platform**

**FR 5.2.7.** The back and sides of each platform (except a 1 meter platform) shall be surrounded by handrails with a minimum clearance of 1.8 meters between pairs. The minimum height shall be 1.0 meter and there shall be at least two crossbars placed outside the platform beginning .8 meters from its front edge.

### **PLATFORM STAIRS**

**FR 5.2.8.** Each platform shall be accessible by suitable stairs (not ladders).

### **COMPLIANCE**

Coaches should inspect diving facilities for compliance with requirements. Coaches need to know the approved dimensions in order to determine compliance and to use good judgment in providing for the athlete's safety.

### **FINA, USD, NCAA, NFSHSA Design Matrix**

Many coaches wear several hats, coaching both high school or college and/or a USD club. The respective governing organization's dimensions may differ somewhat, especially on springboard (See Figure 4.2). High school diving (NFSHSA) is generally limited to 1-meter springboard. FINA, USD and NCAA offer 1-meter and 3-meter springboard and platform competition (See Figure 4.1). Coaches need to know about dimension discrepancies in order to determine compliance and to provide for the athlete's safety.

### **State regulating agencies**

Coaches should be aware of individual state, county and city codes regulating the dimensions of pool design and construction.

### **Compliance inspection**

A tape measure is all that is required to measure the dimensions of the springboards/platforms. Since the board must be in a level position when it is measured, walking out to its end to measure presents a problem. One way to measure without one's body weight lowering the tip of the board is to measure with a plumb line with a bob attached. Tape the line at the end of the board at the 1 or 3-meter mark, then step away from the board to see if the plumb bob just touches the water when the level board is inactive. Another method is to measure at a point 5 feet back from the tip of a level board to the water, the ceiling, and the walls behind or to the sides.

## **AREAS OF CONCERN**

### **SPRINGBOARD**

#### **Springboard Ladders**

Ladders up to the 1- and 3-meter springboards require continual maintenance. Concrete stairs with railings require less maintenance.

#### **Glide Paths**

Offsetting boards on the opposite ends of the pool may help prevent divers from colliding in an underwater glide path.

### **PLATFORM**

#### **Centerlines**

Many new platform towers are being built with three centerlines rather than two. In this configuration, the 10 meter tower has no platform beneath it while the 7.5 meter tower is above the 3 meter and the 5 meter tower is above the 1 meter tower. Such a configuration eliminates the platform below the 10 meter which renders the facility more user-friendly. Lead-ups may be performed on 5 meter or 1 meter and 7.5 or 3 meter without stopping traffic on the 10 meter. This renders a diving facility more functional during times of heavy use such as at large meets or diving camps. When divers travel to a competition, they need to get used to the unfamiliar facility. Given the same number of divers and workout duration preceding a competition, this configuration enables divers to perform more lead-ups and dives than stacked platforms with two centerlines.

#### **Dimension C related to platform locations**

Frequently platforms are incorrectly located during the design and engineering phase because the designer did not read the footnote regarding the modification of platform widths and the respective lateral dimensions, or the designer misunderstood the meaning of this information. The lateral dimensions, after taking into account greater platform widths, can influence the width dimension of the diving pool when a two or three centerline platform is combined with four or more diving board locations.

#### **Cooling Outdoor Platform Surfaces**

Depending on the local climate, designers of platforms in outdoor facilities may want to take into consideration how the platform surfaces are to be cooled. A misting system that sprays the surfaces when they become too hot to the touch is preferable to carrying buckets of water or using a hose. Water piping may be installed in the structure before the concrete is poured.

Figure 4.2 Competitive Governing Body Matrix for Springboard

	NFSA	Board	English	Metric	FINA, USD, NCAA	Board	Direction	English	Metric
	Length of Board	1m	16'	4.877m	Length of Board	1m		16'	4.8m
	Width of Board	1m	20"	.508m	Width of Board	3m		16'	4.8m
A	End of springboard Back to Pool Wall	1m	6'	1.829m	From plummets BACK TO POOL WALL	3m		20"	.50m
B	Closest edge of springboard to pool wall at side	1m	10' A	3.048m	From plummets TO POOL WALL AT SIDE	3m		5'	1.5m
C	Clearance between springboards	1m	8' B	2.438m	From plummets TO ADJACENT PLUMMET	3m		5'	1.5m
D	End of springboard to pool wall ahead	1m	29'	8.839m	From plummets TO POOL WALL AHEAD	3m		11' 6"	3.5m
E	Top of springboard to ceiling overhead	1m	16'	4.877m	On plummets, from BOARD TO CEILING	3m		6' 7"	2.0m
F	None listed				CLEAR OVERHEAD behind and each side of plummet	1m	HORIZ	7' 3"	2.2m
						3m		29' 7"	9m
						3m		33' 8"	10.25m
G	None listed				CLEAR OVERHEAD ahead of plummet	1m	HORIZ	16' 5"	5.0m
						3m		16' 5"	5.0m
						1m	HORIZ	8' 3"	2.5m
						3m		16' 5"	5.0m
						3m		8' 3"	2.5m
						1m	HORIZ	16' 5"	5.0m
						3m		16' 5'	5.0m
						3m		16' 5'	5.0m
H	Depth of water at Springboard	1m	12' C	3.658m	DEPTH OF WATER at plummet	1m	VERT	16' 5"	5.0m
						3m		11'	3.4m
J/K	Distance and depth ahead of springboard	1m	20'	6.096m	DISTANCE AND DEPTH ahead of plummet	1m	HORIZ	12'	3.7m
			11' 3" D			3m		16' 5"	5.0m
						1m	VERT	10' 10"	3.3m
						3m		19' 9" E	6.0m E
L/M	None listed				DISTANCE AND DEPTH each side of plummet	1m	VERT	11' 10"	3.6m
						3m		4' 11" F	1.5m
						1m	VERT	10' 10"	3.3m
						3m		6' 7"	2.0m
						1m	VERT	11' 10"	3.6m
N	None listed				NOTE: Dimensions C (plummet to adjacent plummet) apply to Platforms with widths as detailed.				
A	Using plummet as measurement reference NFSA B would equal 10' 10". FINA, USD, NCAA only require 8' 3".				If Platform widths are increased then C is to be increased by half the additional width(s).				
B	Using plummet as measurement reference NFSA C would equal 9' 6". FINA, USD, NCAA only require 6' 7".				MAXIMUM SLOPE TO REDUCE DIMENSIONS BEYOND FULL REQUIREMENT FOR POOL DEPTH & CEILING HEIGHT IS 30 DEGREES				
C	Water depth at any point 2' to 5' in front of the end of the board shall be 10' (3.048m) with 12' (3.658m) or more preferred.								
D	Maximum depth reduction rate of diving pools which do not exceed minimum depth requirement shall be 5.14% for a distance of 20' (6.096m) forward and 6' (1.829m) back and to the sides. eg. If the pool is 10' deep (3.048m) as permitted in pools constructed prior to 1987, the depth 20' ahead of springboard must be a minimum of 9' 4.17" (2.858m) i.e. .0625 x 3.048 (10) = 1.995; 3.048 minus 1.995 = 2.857m.								
E	Deeper pools may have proportionately steeper depth reduction rates.								
F	NCAA requires only 16'5" (5M)								
	NCAA rounds to 5'								

NFSA-National Federation of State High School Associations 1998  
 FINA-Federation Internationale de Natation Amateur 1998-2000  
 USD-U.S. Diving, Inc. 1998-1999  
 NCAA-National Collegiate Athletic Association 1998

## **FACILITIES' DESIGN CONSIDERATIONS**

### **Bidding for major events**

The minimum dimensions are permitted in all competitions except the Olympics and the World Championships, which require the preferred dimensions in all cases. Facilities that meet or exceed preferred dimensions have a distinct advantage of being awarded a sought-after competitive event.

### **Staging**

Keep in mind where the following will be located: 1) awards ceremonies, 2) meet management score tables for individual or simultaneous events, 3) lifeguard chairs, 4) lifeguard equipment, 5) telephone with access from the deck, 6) clock visible from the deck, 7) spectator and judges seating that does not impede deck traffic, 8) diving judges seating placed either together on one side of the pool or separated on both sides, 9) diving judges seating for platform events, and 10) electrical power outlets on the deck to run scoring table computers, fans to keep the judges cool, and cameras.

### **Installing a non-slip surface on Platforms**

When covering the platform facing and installing the covering, keep in mind the diving performance and safety objectives (see Figure 4.3).

## **REFERENCES**

FINA Handbook 1998-2000 Constitution and Rules. FINA Office (Ed).

Gabriel JL (1992) Diving Safety, A Position Paper. Indianapolis, IN: U.S. Diving Publications. p. 16.

Hunsaker, DJ. (1990) Design Compendium for Competition Swimming and Diving Pools, National Swimming Pool Foundation.

National Federation of State High School Associations Swimming and Diving Rules (1998) Kansas City: MO.

Official Rules of Diving & Code of Regulations of United States Diving, Inc. (1998/1999). Indianapolis, IN.

# INSTALLATION OF PLATFORM SURFACES

The objective of the installation of a non-slip and resilient platform surface is to: 1) provide for a comfortable and secure top surface and leading edge of the platform for the diver to take off from; and, 2) provide added safety protection if the diver strikes the front face of the platform. When installing a surface on a platform, whether it is Mondo or Rough Tex, following these procedures will help to achieve the best results for diving performance and safety:

## 1. Covering the Platform Facing

If constructing a new platform, the front facing can be designed to accommodate a piece of the platform covering to help it stay fixed in place more securely. This is done by creating a lip at the bottom of the facing. A steel frame may be fabricated to encase the concrete platforms. The front edge is fabricated to include a recessed lip slightly less than the thickness of the covering.

A piece of the covering is then measured and cut to fit the front edge of the platform, and glued from the lip to the top of the platform runway. The intent is for the front edge of the lip to be slightly indented @ 1/8 inch from the front edge of the front facing covering. The front edge of the lip should not, in any case, protrude out farther than the front edge of the facing covering.

If the platform is an existing one and does not have a lip, then the piece of covering is installed on the whole face of the front end. In either case, it is important that the bottom edges are cut very square. The top of the piece must align precisely with the top of the platform.

## 2. Installing the covering

The covering should be glued down from the front of the platform to the back. Allow a small overhang of about 1 inch, and no more than 2 inches, on the front edge. This helps the top cover to adhere to the piece on the facing more securely. Once it has firmly set in place, the overhang is removed with a sharp cutting instrument to create a sharp 90 degree angle.

The final result is for the front edge of the facing covering and the top surface covering to be flush.

### Side View

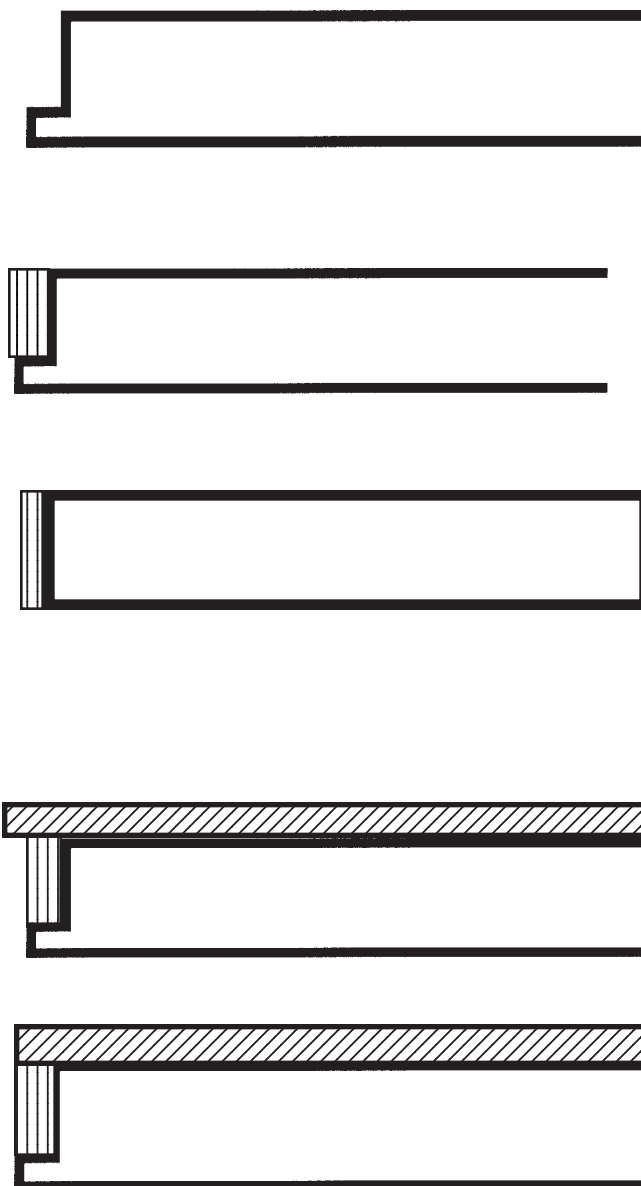

 Facing covering

 Top Covering

Figure 4.3 Installation of Platform Non-Slip Surfaces

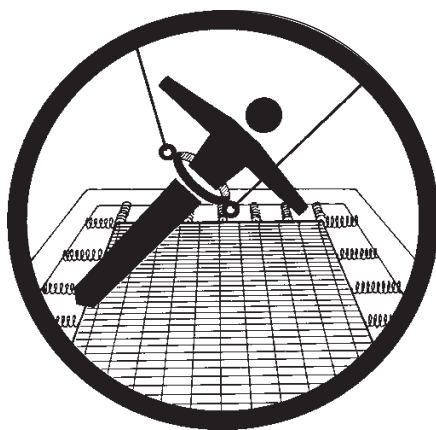

## CHAPTER V

# COMPETITIVE DIVING EQUIPMENT

### CHAPTER COMPETENCIES

#### Upon completion of this chapter, coaches should be able to:

- Know that safety equipment, coach's vigilance and other safeguards may provide a means of injury control.*
- Inspect equipment for potential safety hazards prior to each use.*
- Know the applicable safety standards for diving equipment; regularly inspect equipment for compliance with all safety requirements.*
- Know how to arrange for repair/replacement as needed.*
- Recognize the environmental and safety hazards likely to affect divers in practice and competition, such as wet or slippery diving board and platform surfaces, sparging systems components that inappropriately protrude into the water envelope and/or inappropriate matting.*
- Establish and follow procedures for identifying and correcting unsafe conditions.*
- Stop or modify practice or competition when unsafe conditions exist.*
- Verify that diving boards meet competitive standards required by the rules governing competition.*
- Verify that sparging systems, trampolines and overhead spotting rigs comply with U.S. Diving's specifications and recommendations for use.*
- Know that equipment is intended to be installed and maintained subject to the manufacturer's specifications.*
- Require the appropriate use of somersaulting and twisting safety belts during practice.*
- Assist divers in choosing and fitting safety belts if needed.*
- Assist divers in using an appropriate fulcrum setting.*

# Part 1. Competitive Springboards: Duraflex

by Ray Rude

## HISTORICAL PERSPECTIVE

Diving was first included in the Modern Olympic Games in 1904. Since its inclusion as an Olympic event, the competitive diving board has evolved, resulting in considerable improvements in safety. The construction material has changed from wood to an aluminum alloy. Running approaches were once imperative for board clearance on forward and reverse dives because there was an upward slope from 2.0-3.2 degrees. The slope has gone from an 8 inch elevation to level. The length has changed from 12 feet to 16 feet. Fulcrums have gone from rigid to adjustable (Miller, 1985).

The construction of the competitive springboard has undergone three major stages of improvements. In the first stage from the 1920s-1940s, the competitive board was a heavy wooden plank. Stanford coach Ernst Brandsten changed the board from six 2-inch by 4-inch strips of straight grained white ash plank, 12-13 feet long, covered with cocoa matting, to a one piece, 14 foot long straight grain plank of Oregon pine. Coach Brandsten modified the fulcrum placement from 33 percent to 57 percent of the board length from the tip. He changed the fixed fulcrum to one with limited mobility.

The last two stages of springboard evolution were spinoffs of the aircraft industry (Miller, Jones & Pizzimenti, 1988). In 1948 Norman Buck revolutionized the industry with an I-beam design of 300 interlocking pieces of war surplus square aluminum tubing originally used in B-17 aircraft. The 'Buck-board' was then used in major competitions for about a decade. The third stage of evolution began in 1949 when Duraflex developed a two-piece aluminum springboard. With the diver's safety in mind, the board was developed under the premise that the perfect springboard would be one that was weightless. If human body parts were to strike a weightless object, injuries would be zero. This prototype of today's competitive board has retained the same design since its inception.

Improved aluminum alloys that provide greater strength and lighter weight have been used in the Duraflex board's refinement. The board has been reduced in weight from 150 to 128 pounds. The original Duraflex was machine-tapered from fulcrum to tip. In 1969, the Maxi-Flex added a second taper from the fulcrum back to the anchor. In 1979, the Maxi-Flex Model B modified the tip with perforations.

## SAFETY FEATURES OF THE MODERN COMPETITIVE BOARD

Since World War II, technological advances in the competitive springboard manufacturing industry have

produced lighter, thinner springboards out of aluminum. Improvements with lighter materials and a design of very low mass have enhanced the safety as well as the performance aspects of the sport of competitive diving. Today the two lineal feet at the tip of the springboard weigh less than 10 pounds. The combination of the low weight, low mass features of the modern competitive equipment minimize the potential for injury from an accidental fall or collision of the hand(s), arm(s), and especially of the head with the board due to the resiliency of the tip.

Another improved feature of today's competitive springboard is the **non-skid or non-slip surface**. Through years of extensive manufacturer's experimentation with dozens of different materials, it was discovered that the depth or height of the water on the surface of the board was the most critical safety factor the design had to take into account. Consequently, a dull background treatment was used, since it was discovered that water stands higher or thicker on a surface that has a gloss background, regardless of the size and shape of the granules used. The factory finish is a result of highly developed technics. Non-skid materials are bonded to the aluminum with epoxy. One of the construction materials works to reduce surface tension of water so that water doesn't "stand high" on the board.

Factors considered in the application of human hydroplaning to springboard design are speed, inertia, momentum and weight (mass) of the human body, given a few square inches of contact area. When the diver comes to an abrupt stop in the approach or take-off preceding a dive (when the diver balks), momentum change bears heavily on the board surface. The most wear is from the hundreds of users' feet that go down the length of the board, and the many times they turn or rotate at the tip. The first area of the springboard to show wear is the 18 to 24 inches at the tip. The non-skid surface of a springboard will also show deterioration from environmental conditions such as sun, water, chemicals and dirt. Given the corrosive conditions indigenous to swimming pool environments, compliance with the manufacturer's installation and maintenance instructions is imperative (see Figure 5.1.1).

**WARNING: The instructions in this article are specific to FINA approved competitive Duraflex equipment. Instructions for competitive and recreational diving boards are unique to each manufacturer. Always follow the instructions specific to the equipment's manufacturer.**

## **MAINTENANCE OF DURAFLEX DIVING BOARD'S NON-SKID SURFACE**

Coaches should be aware of the following maintenance requirements established by Duraflex for the competitive board's non-skid surface.

1. **The surface of the board must be tested and found to be sufficiently “non-skid” WHILE THE SURFACE IS WET** by the pool manager when the board is put into use each season. The pool manager must instruct the lifeguards (or other responsible supervisors) to test the surface **WHILE WET each day** at the start of their shift of duty. The pool manager and lifeguards are responsible for the pool user's safety; if a diving board is slippery, it must be taken out of service.

2. Causes for the competitive board to become slippery are usually the following:

- Dirt from the environment, plus oil and calloused skin of swimmers and sunbathers
- Excessive wear or years of normal wear
- Excessive alkalinity or excessive minerals in the water

3. **Maintenance Methods:**

- Hose off the board when you wash the pool deck (more than once a week)**
- Scrub with detergent or chlorine and very hot water, monthly or when needed. Use a plastic or fiber-bristle brush**
- Muriatic acid may be used to remove algae or stains**

4. What to do about a worn-out surface on the competitive board:

**Take the board out of service if it is slippery and contact the factory for refinishing.** No home remedy attempt at refinishing the board is satisfactory.

## **BOARD, FULCRUM AND STAND**

### **Design**

An accomplished diver by bouncing a 16 foot board can depress the tip more than one meter. To depress the same board the same distance with dead weight, would require seven times the weight of the diver. In terms of impact loads, the download on the fulcrum could reach as high as 3,000 pounds. Obviously the springboard stand must be very strong to support and withstand the 3,000 pounds upload of the anchor end of the board.

## **Maintenance of Duraflex board's fulcrum contacts**

The rubber channels on the underside of the board must be inspected monthly for signs of wear. They must be replaced if worn to the point that the metal ribs contact the fulcrum. The board is not allowed to contact metal.

## **Maintenance of Durafirm stands**

1. Hose off the entire stand with fresh water on each day of use. Keep the fulcrum components clean, especially the tracks.

2. Keep the roller clamp lock nuts and anti-rattle lock nuts snug and adjusted for a “no-rattle” clearance.

3. The two grease fittings of the roller should be lubricated every 2 weeks. (Use “Mystik JT-6” grease and grease gun.)

4. The hinges which hold the board to the stand need 2 drops of oil every 2 weeks. (Use lightweight oil as for door hinges.)

5. Concerning guard rails: “304 stainless” is the best stainless steel for guard rails in the swimming pool environment, but it is not rustproof. Clean with stainless steel cleaner and a cloth if rust appears. Rinse with large amounts of fresh water (not pool water).

## **Additional Maintenance**

Bolts, fasteners, diving boards and stands should be carefully examined at the beginning of each season for corrosion, erosion and looseness. First check the bolts attaching the board to the stand. In the case of Durafirm stands, all bolts in the area of hinges and upper cross members of the 1-meter and 3-meter ladders need careful inspection.

## **INSTALLATION**

Special care needs to be given to proper installation of springboards and stands (see Figure 5.1.2 for a summary of the Manufacturer's Installation Instructions for Competitive Springboards). Often, a general contractor hired to build an entire sports complex does not have experience with the building of pools. It should not be assumed that the general contractor is familiar with the proper, precise installation procedures, especially with regard to pitch and level of competitive boards. A prudent pool manager will check the installation of boards and stands for compliance with the installation procedures recommended by the manufacturer, FINA and U.S. Diving competitive specifications.

## **Competitive governing body guidelines**

According to the competitive diving board specifications of FINA, the international governing body of the sport of competitive diving, (FINA Handbook 1998-2000, FR5 Diving Facilities) the competitive board shall:

1. be at least 4.8 meters (16 feet) long and 0.5 meters (20 inches) wide.
2. have a satisfactory non-slip surface.
3. be provided with movable fulcrums easily adjustable by the diver.
4. follow the minimum distance recommended by the manufacturer from the anchor to the center line of the fulcrum, as different types of diving boards will use different anchor to fulcrum minimums.
5. be allowed to vary by five percent from 1-meter and two percent from 3-meter springboard above the water level.

In addition, the 1998-1999 U.S. Diving Rules and Regulations (Section 101.2, Equipment Regulations for Springboard) recommends:

6. that the front edge of the board shall project at least five feet, and preferably six feet, beyond the edge of the pool.
7. that 3-meter springboard stands be equipped with safe guard rails that extend at least to the pool edge and will prevent divers from falling off the board onto the deck at the sides.
8. that the depths of water shall be in accordance with FINA Recommended Dimensions for Diving Facilities.
9. that there be mechanical surface agitation under the diving boards to aid the divers in their visual perception of the pool.
10. that springboards be installed approximately level (*within 1/16 inch per foot is realistic*) at the tip (over the water) when the fulcrum is at a midpoint along the track, and,
11. that springboards be installed according to the manufacturer's specifications (see Figures 5.1.1 and 5.1.2).

## REFERENCES

- Federation Internationale de Natation Amateur (FINA) Handbook (1998-2000) 374-380.
- Miller DI, Jones IC, Pizzimenti MA (1988) Taking Off: Greg Louganis' diving style, SOMA: engineering for the human body. 2: (4) 25.
- Miller DI (1985) Factors limiting springboard diving performance: historical and biomechanical perspectives. American Academy of Physical education Papers. 18: 101-105.
- United States Diving Rules and Regulations (1997-1998) 1:001-1:002.

Figure 5.1.1 Manufacturer's specifications for installation of Duraflex and Maxiflex boards on Durafirm short stands

The dimensions listed in the table refer to the installation of Duraflex and Maxiflex boards on Durafirm Short Stands

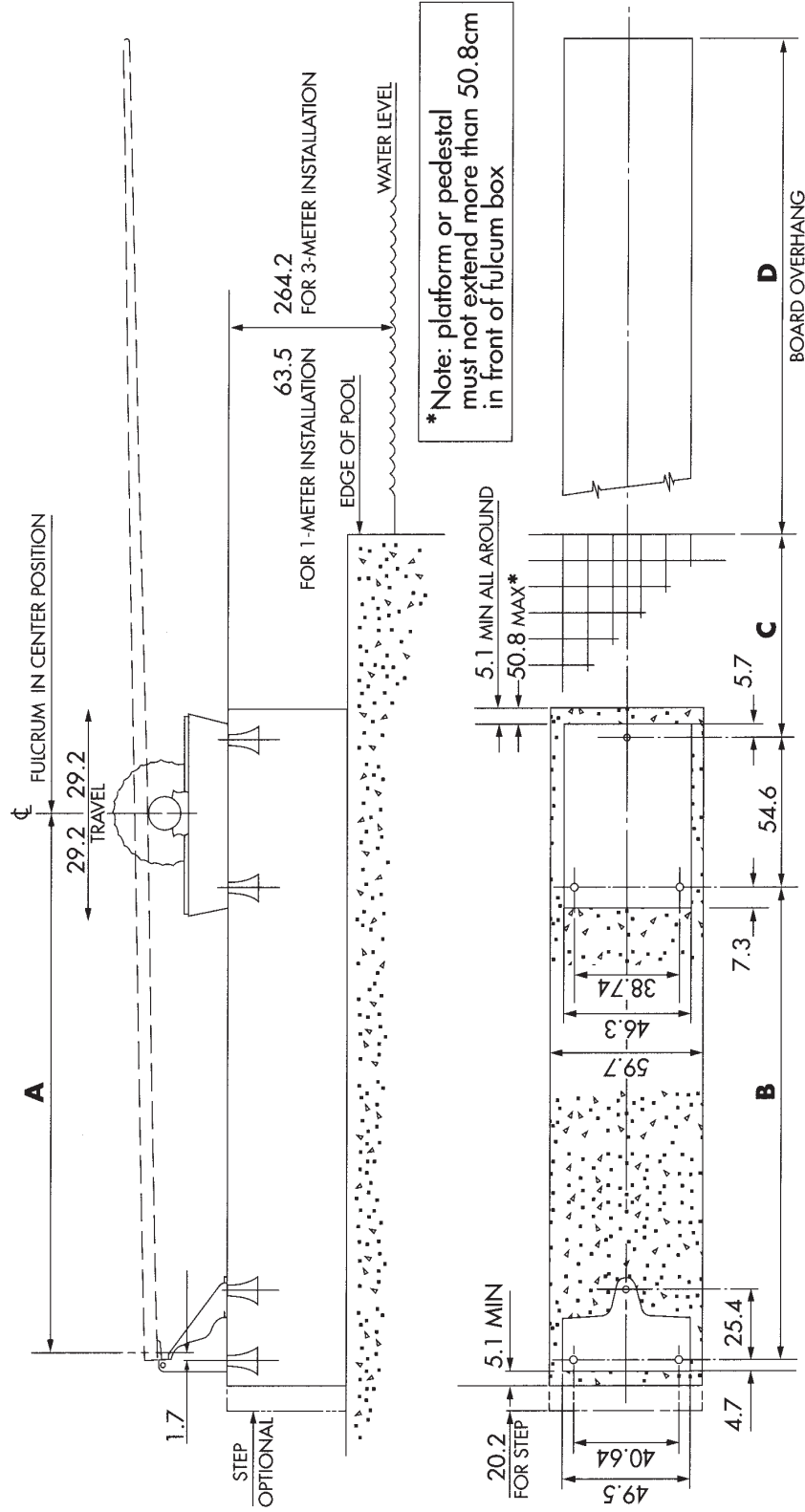

	14 ft. 426.7cm	16 ft. 487.7cm	16ft. maxiflex 487.7cm
<b>A</b>	160.7	198.8	184.8
<b>B</b>	135.9	174.0	160.0
<b>C</b>	53.3	76.2	91.4
<b>D</b>	183.0	183.0	approx 183.0

Note: C dimension decreases to 50.8cm if platform is vertically plumb with pool edge, and board overhang increases correspondingly.

\* Contractor must see that diving well will meet minimum depth ahead of board if overhang is increased.

ALL DIMENSIONS SHOWN IN CENTIMETERS (CM)

<b>DURAFLEX INTERNATIONAL CORP.</b>			
TRACY, CLARK STATION	SPARKS, NEVADA		
PART NO.	SHORT STAND STAND ASSY		
70-231-524	ADDITIONAL SHEETS	INSTALLATION DETAILS	TOTAL SHTS.
DURAFIRM DIVING STAND			
SCALE	SS 524 cm		

## SUMMARY OF MANUFACTURER'S INSTALLATION INSTRUCTIONS FOR COMPETITIVE SPRINGBOARDS

BOARD MODEL	DISTANCE TO CENTERED FULCRUM	FULCRUM RANGE
16' Duraflex	78 inches (198 cm)	66-90" (168-229 cm)
16' Maxiflex	74 inches (188 cm)	61-87" (155-221 cm)

All dimensions above are measured forward from the center line of the rear anchor bolt. A movable or fixed fulcrum must be adjusted to operate in the fulcrum range indicated for the springboard model.

### GENERAL INSTRUCTIONS

The preferred pitch or "rise" of the board for competition should be zero, with no load, i.e. level. The tip of the board should never be lower than level. The anchor end of the Duraflex is designed to be bolted directly to the top of the pipe structure, with no padding between. If shimming to achieve proper slope is required, a 21 inch length of maple oak, ash or equivalent hard wood can be used between the board and the pipe structure. All ribs must bear on this wood shim, and bolts must be tightened thoroughly.

It is advised that you bounce the board freely a few times before final tightening of the anchor bolts, to determine if there is a tendency of the board to drift sideways at the tip. If the board does drift, it can be centered before final tightening and then rechecked for drift tendency. It is important that the board be centered between any protruding parts of the fulcrum so that the sides of the board never contact the fulcrum mechanism.

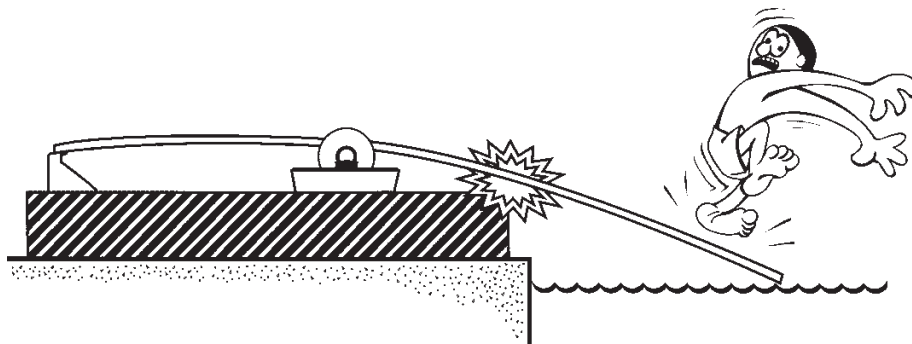

The Duraflex warranty is void if the board is allowed to strike metal or concrete supports either at the sides or underneath the board. For protection from contact with metal of fulcrum, Duraflex installs vinyl channels on the ribs of the board in the fulcrum area on Duraflex 16 foot boards. Protection on non-Duraflex supports is to have a minimum of 3/8 inch thick, high-quality rubber sleeve or pad on the fulcrum. Vinyls and the rubber sleeve must be checked for wear and replaced if ribs appear to be cutting through. Duraflex vinyls can be ordered. (Specify if board is older than July 1962). Order set of eight vinyls 30 inches long for movable fulcrums.

If you are installing the board on a Duraflex Durafirm Stand, use Bronze Board Bolts 3-1/2 inch (Duraflex part #SF122).

See Duraflex Refinishing sheet regarding frequency and procedure for refinishing Duraflex boards.

*Figure 5.1.2 Installation Instructions*

## Part 2. In Ground Sparging Systems

by Herb Flewwelling

### PURPOSE AND MECHANISM

The air sparging system or “Bubble Machine” was invented to reduce pain and the likelihood and magnitude of injury when learning new dives. The air sparger, located on the pool bottom, injects air at high velocity into the pool creating a 50/50 mixture of air bubbles in water that rise and form a mound above the normal surface level of the pool to cushion the entry. Although diving is a non-contact sport, water entry is a collision skill performed without protective padding. The force of impact on the water when the diver’s body lands flat (i.e. horizontally), subjects the body to rapid compression and distortion of tissues as the result of extreme deceleration. Besides physical discomfort, a traumatic flat entry on “solid” water without bubbles can also result in injury, such as detached retinas or ruptured internal organs.

### Design factors

The force of impact, measured in thousands of pounds on a diver’s body landing horizontally from 10-meters, is proportional to the square of the impact velocity and directly proportional to the viscosity and density of the water. The sparging system utilizes three factors in its design to reduce the force of impact: (1) air/water mix, (2) compressibility, and (3) mound effect. By mixing 50 percent air into the water, the force is reduced by half. Even though water is relatively incompressible, air is very compressible. Thus, it is possible to further reduce the force because of the compressibility factor or foam rubber effect, (note that rubber is quite hard in the absence of air bubbles). Finally, the mound effect is important because it allows lateral displacement as does a pile of sand on the beach when you jump on it as compared to jumping on the flat solid sand.

### Effectiveness and limitations

These three factors in combination can reduce the impact force by about 80 percent. This means that landing flat from 10-meters with bubbles would result in about the same impact as landing flat from 2-meters on “solid” water. Even with the reduction of force afforded by the sparging system bubbles, the impact force is still sufficient to knock the wind out of the diver or pull a muscle if the diver is not tight (rigid) on entry. Coaches should emphasize proper body alignment at entry when the bubbles are used. The bubbles will not protect the diver from alignment injuries such as arms out of line with the body or an extreme back arch on vertical entry. **The sparger should be used primarily when there is risk of a flat or nearly horizontal landing.**

### Maintenance

The sparging system should be installed and maintained in accordance with the manufacturer’s specifications. When the sparging system is improperly maintained and the volume of air is reduced, a risk of injury is created. With even a 10 percent mixture of air, the water still looks turbulent and white, but the cushion effect has been all but eliminated. However, the water turbulence created by the air jets still remains, creating currents that can force the arms or back out of line on vertical entries, resulting in possible injury. Maintenance on a pressure vessel requires the expertise of a licensed pneumatic specialist as these vessels can explode just as can a scuba tank filled with compressed air. The safety inspection of the pneumatic equipment - including compressors, valves, gauges and pressure vessels - must be carried out according to the most stringent of the schedules laid out by the manufacturer, national electrical and plumbing codes, municipality, state or other regulating bodies. Unqualified personnel might replace fittings with undersized inside diameters, thereby reducing the effectiveness of the system without the coach’s knowledge. A good check on the effectiveness of the repair is to note that there should be no apparent reduction in the mound size when the bubbler is activated.

### APPROPRIATE USE OF BUBBLES IN THE SKILL PROGRESSION

The sparging system enhances the divers’s ability to concentrate on the technique of the dive rather than the landing or final result, thus reducing the possibility of injury. Once the confidence in the successful outcome has been established, there should be no further need for the bubbles. However, sometimes in the learning process or even after skill mastery has occurred, a diver may experience disorientation in a somersault or twist that may result in a traumatic landing. This situation may warrant the use of the bubbles, depending on the level of performer readiness.

Divers also use the bubbles to perform lead-ups in a skill progression where there is a risk of landing a bit flat. An example would be a back somersault with 3 1/2 twists on 5-meter as a lead-up for a back 3 1/2 twister on 10-meter. Proper body alignment is also important on feet-first entries; the diver should hold the feet together and muscles rigid to minimize injury. Proper skill progressions are critical to safety in diving. As with other safety aids, **the bubbles are no substitute for proper skill progressions.**

## OPERATING PROCEDURES

In using the bubble machine, follow the manufacturer's instructions for its proper use. Since the sparging systems are custom designed, they vary from pool to pool.

### Equipment operation

Generally there is a cabinet, locked when not in use, that includes: (1) the activator or "on/off" button on an extendable cable, (2) selectors for the individual spargers located under various diving boards, (3) selectors for bubble surface agitators if included, and (4) a gauge indicating the air pressure in the storage tank.

**There is an indicator of the operating zone that is usually above 100 pounds per square inch.** If the pressure is below this limit, wait a few minutes until the pressure returns to the operating level (which usually does not exceed 200 P.S.I.). If the air pressure returns very slowly or not at all, report this to your maintenance staff.

Always check the pressure before each use, as insufficient pressure reduces the cushioning effect of the bubbles and, on some machines that have air-activated valves, will prevent the bubbles from being shut off.

### Predetermined start procedure

When operating the bubble machine, a predetermined start procedure must be agreed upon by coach and diver. An audible count of "5" with one count per second is recommended, however it may be modified to meet individual needs, for instance, in the hearing impaired performer. Using the "5" count procedure the diver starts his/her takeoff on "5" to avoid confusion. During the count, the operator should check to see that the bubbles are indeed coming out of the sparger at the bottom of the pool. Before "five" is called out, the operator confirms to the diver that the bubbles are up on the surface as a final check in case of malfunction.

Depending on the installation, the "on" button may be pushed on any number from 0 to 3 depending on the lead time required for the dive. For example, an inward 3.5 somersault on the platform may be started right on "5," where a forward running dive should not leave the platform for an additional couple of seconds. This means that the push button can be activated a couple of seconds later on this dive than on the inward takeoff dive. Armstand dives may be performed by pressing the button on a signal from the diver. The diver should wait until the bubbles are at the surface before kicking or pressing up on handstand dives.

The bubbles should be shut off as soon as the diver lands, both to save air for additional dives and as a safety precaution.

### Safety Precautions

Reasons for shutting off the bubbles immediately upon entry include:

1. Inexperienced divers not used to the bubbles may temporarily get disoriented and panic in the turbulence.

**Divers uninitiated to the sparging system first should be given an opportunity to swim in the bubbles to orient themselves to its feel and action.** Likewise, those uninitiated in entering bubbles from the 10-meter platform should test a head-first entry on a lower platform or experience a feet-first entry from 10-meter so they know what to expect.

2. The upward current in the center of the pool caused by the upward displacement of the low density air/water mixture creates a current across the pool and down to the bottom at the sides, and then return to the base of the sparger. This downward current at the side can carry an unsuspecting younger diver downward and create short-term panic. The diver should be made aware of the possibility of this, and coached to grab the side of the pool. For small children, the coach or another diver should stand by the pool and remind them to grab the side. Also, if the diver is unaware of the current, he/she could collide with the side or a ladder and bump his/her head, teeth or arms. Again, by swimming in this mild current one learns what to expect. Also if the bubbles are shut off immediately, this current is stopped. The same precautions as swimming at an ocean beach for the first time are recommended.

3. This current creates an additional safety problem. **The diver landing in the bubbles will normally be swept laterally across the pool in front of other boards. For this reason, the coach must request and verify that other diving activity in the diving area ceases before the operator activates the bubbles. Other diving activity should not be resumed until the diver using the bubbles has exited the pool.**

Not only have hundreds of thousands of competitive dives been performed safely into bubbles using properly operated bubble machines worldwide, but, in addition, many new uses have been found for this system. White water canoeing, surf simulation, treadmill swimming, handicap float swims, automatic skimming and vacuuming, and general pool party fun are a few of these recreational uses. **Do not mix recreational and competitive activities.** If divers are using the bubbles for training, no recreational activities should be allowed at the same time. An unsuspecting swimmer may just pick that moment to try the bubbles for the first time. Although this may not seem probable, ask others present to stand well away from the area so that there is no possibility of a collision.

### Additional safety considerations

In many facilities, two boards with adequate clearance in between are often situated together. Due to the currents that sweep the diver laterally across the pool toward the sides, consideration should be given to installing the sparging system under the board farther away from the side wall whenever practical. Installing the sparger under the inside board may also reduce the amount of water splashing onto the deck.

Additional secondary safety recommendations are basically common sense considerations, and those included in municipal safety codes. For example, electrical equipment must be inspected periodically and kept away from the water. Avoid setting the activating (on/off button) control where it could come in contact with water or a damp surface. During competitions, electrical wires for sound systems, etc. are sometimes installed on the deck. If the waves from the bubbles were to reach these wires, a hazard could occur.

## **OPERATIONAL SAFETY GUIDELINES**

1. Install, maintain and use the sparging system according to the manufacturer's and the regulating bodies' specifications, standards and inspection schedules.
2. Emphasize proper body alignment and rigidity even though the bubbles are in use.
3. Use sparging system bubbles as a supplement to proper skill, not as a substitute.
4. Lock the cabinet when not in use to prevent any unauthorized use.
5. Check that the indicator registers adequate pressure before activating the system.
6. Use a predetermined start procedure agreed upon by coach and diver.
7. Divers should wait until the bubbles are at the surface before kicking or pressing up on armstand dives.
8. Use the bubbles when there is a risk of landing flat on new dives or problem dives. Do not use the bubbles as a crutch.
9. Shut the bubbles off as soon as the diver lands.
10. Do not mix competitive and recreational sparging system activities.
11. Acclimate users to the bubble conditions.
12. Take extra care with small children in the turbulence, downward and upward currents. Be in position to assist them as they approach the side wall in the current. Watch to make sure they surface and grab the side of the pool.
13. Protect the head and teeth with the hands and arms against collisions with the side of the pool or ladder in the upward current.
14. Do not set the activating control in an area where it could come in contact with water or a damp surface.
15. Follow appropriate safety inspection schedules and procedures.
16. Coaches using the sparging system should be familiar with the necessary safety precautions and provide appropriate supervision.

# Part 3. Above Ground Sparging Systems

by Robert Ketrick, M.S.

With the advent of the above ground sparging system, there are many new parameters that come into play with its use. Above ground systems meeting the design specifications (see Table 1) will deliver an air/water mix ranging between 25/75 to 50/50. The design factors, predetermined start procedures and operational safety guidelines are the same as those discussed in Part 2 for embedded in ground sparging systems. This part will focus on insurance requirements, maintenance, operating procedures, and the new system configuration recommendations for above ground sparging systems.

## INSURANCE

Above ground removable sparging systems are included in U.S. Diving insurance coverage according to the current guidelines. In order to be eligible for consideration of inclusion, above ground systems must meet the following criteria:

- conform to system configuration recommendations in Appendix A
- be securely affixed to the pool bottom or adequately weighted in a manner that the system cannot be inadvertently misaligned by ordinary usage or any reasonably anticipated misuse.

Any above ground system not in compliance with these criteria must upgrade in order to remain insured by U.S. Diving

**WARNING! Coaches are cautioned that when charged with air, a system not securely affixed to the bottom or adequately weighted that raises or displaces itself from the bottom presents a danger of collision with the diver.**

## DESIGN

It is highly advisable that a reputable engineer verify, in writing, that the design used meets the Design Specifications in Appendix A and can safely support the intended use of the above ground sparging system in your facility.

## SAFETY INSPECTION & MAINTENANCE

The safety inspection of pneumatic equipment including compressor, valves, gauges and pressure vessels must be carried out according to the most stringent of the schedules laid out by the manufacturer, national electrical and plumbing codes, and municipality, state or other regulatory bodies. Coaches should inspect the hose and the distribution head daily for signs of wear. If you even suspect a flaw or weakening of the apparatus, do not use the system. Also check for cracked or broken PVC; verify that the system remains adequately weighted or securely affixed. Ascertain that bolts, when used, remain flush and do not protrude. Inspect the hydraulic hose for any defects. Inspect the PVC distribution

head for damage or wear. Do not use the system if there is any question about the integrity of the hose.

The above ground sparging system requires the highest level of attention to maintenance. Have worn parts replaced at once. Maintenance on a pressure vessel requires the expertise of a licensed pneumatic specialist as these vessels can explode.

## OPERATING PROCEDURES

Each above ground system's configuration can vary between the minimum and maximum configurations. Coaches will need to work with an engineer to detail operational procedures specific to their customized system.

## Equipment operation

Before the compressor is started, the release valve of the delivery system needs to be closed and the distribution system positioned properly. Then, turn the compressor on. **Normal operational air pressure levels are between 120 psi and 180 psi. Do not operate the system outside this pressure range.** When installing, be sure that the pneumatic engineer tests the automatic cut-off valve so that it meets the manufacturer's specifications for maximum cut-off pressure.

## Start up Safety Check

Prior to using an above ground sparging system, coaches will need to test it for stability. A system safety check should be performed from a fully charged system without divers present. Once the compressor has filled the tank to 180 psi and turned off, open the system to full force to test all its components. Let the system run for 10-15 seconds, then shut it off. Inspect the delivery system for any displacement.

## Safety Precautions

In addition to precautions listed in Part 2, coaches should:

- Inspect the removable equipment on a daily basis. Always set up the system with the work area clear of all divers and others in the pool.
- Be sure that the holes are facing up before pressurizing the system.
- Once the system is pressurized, test the distribution system while there is no one in the diving well.
- Stop all other boards and platforms before dispersing air into the distribution head.
- Always keep your hand on the cut-off valve. Be prepared to cut off the air supply at any sign of system failure.
- Only a coach familiar with the system and these safety precautions should operate the system.

## APPENDIX A: DESIGN SPECIFICATIONS

Table 1. System Configuration Recommendations

Item	Minimum	Maximum
Compressor	5hp	25hp
Storage Tank	80 gallon	400 gallons
Deliver System	3/4" I.D.	2 1/2" I.D.
Sparger Head	150 - 1/8" holes	30 - 1/2" holes
Length	9 feet	16 feet

### VARIATIONS

These recommendations are based on the best information currently available specific to above ground sparging systems and as such are subject to revision as additional research findings become available:

#### Compressor

The horsepower rating of the systems may be varied within the defined ranges. The larger the compressor the faster the storage tanks will refill. The higher the horse power of the compressor the more it will cost. For larger storage tanks, larger compressors are recommend to recharge the system at a reasonable rate. All systems must have a cutoff switch that automatically shuts off the compressor when the internal pressure of the storage tank reaches 180 psi.

#### Storage Tank

Storage capacity can be increased from minimum to maximum as desired. Increasing the storage tank size will allow for longer operation, thereby reducing system recharge time. This decreases the divers wait time in between uses of the sparging system, and will help in running practice more efficiently.

#### Delivery System

The inner diameter (I.D.) of the minimum system recommendations may be increased as desired up to the maximum specification. Increasing the inner diameter size will increase the air/water mixture and improve the compressibility, thus the softening effect of the system.

Inner diameter is determined by the smallest inner diameter of any one component in the system. In designing your system be careful to avoid any bottle necks. An example of a bottleneck is a 2" I.D. pipe with 1" valves. The 1" valve will create a bottleneck in the system and restrict the airflow, thereby reducing the air/water mix.

#### Sparger Head

This parameter may vary. Sparging heads with more holes were found to create a more evenly distributed bubble

pattern in sparging systems using a smaller diameter. Uniformity of the bubble pattern was less consistent with larger inner diameter systems.

#### Length

The recommended length is 9 feet to 16 feet; do not vary this parameter below 9 feet.

#### Configuration for platform heights

The highest risk of injury for a diver is to land flat on the water with 0 percent air-water mix. This is when the water is least compressible. Any air injected into the landing area increases its compressibility and will decrease the impact felt by the diver. The embedded (in ground) industry standard sparging system provides a 50/50 air-water mix.

Above ground sparging heads that follow the "Minimum" system configuration recommendations listed (see Table 1) provide a 25/75 air-water mix which is an acceptable level of protection from the 1-, 3- and 5-meter levels.

**To provide an acceptable level of protection from the 7.5- and 10-meter level using an above ground sparging system, systems must comply with the "Maximum" specifications (see Table 1) for the storage tank size, delivery system's inner diameter, sparger head and length.**

#### Pool depth of water envelope

A diver reaches the bottom with the greatest velocity with no air at all injected. An air-water mix as low as 5 percent adds to the diver's negative acceleration and therefore aids the diver's decreasing velocity in the envelope. Nevertheless, the installation of an above ground sparging head must not compromise the FINA minimum dimensions. Above ground sparging heads are not recessed into the pool bottom, therefore the pool depth must exceed FINA's minimum dimensions by a distance equal to or greater than the height of the sparger head. Provided the water depth does not compromise the FINA dimensions, low profile designs (less than 5 inches) pose no unreasonable risk of injury provided the underwater profile of the pool is not violated. No sharp bolts should protrude.

#### Installation

Sparging systems should be centered in front of the board or platform. The beginning of the sparger head should be aligned approximately 1 foot in front of the plummet.

#### Materials

PVC may only be used after the last valve in the system. The first is nearest the compressor, the last is farthest from the compressor. Galvanized steel must be used as the air conduit up to the last valve. Industrial grade high pressure hose rated at 400 psi with pressure fitted connectors (brass or stainless steel) are recommended. Quick disconnects are to be used to connect the hose to galvanized steel and to the sparging head. Use round headed bolts when bolts are needed to securely affix the system to the bottom.

# Part 4. Spas and Hot Tubs

by Gerald DeMers, Ph.D.

Hot tubs are becoming standard equipment at diving facilities. They can help maintain the diver's body temperature and keep muscles relaxed. Though this can be a real advantage to a diving program, there are many hazards relating to the operation and use of a hot tub. The diving coach must be aware of these hazards in order to ensure the safety of those using the facility. Though some of this information does not relate directly to a competitive diving program, it is important to mention in this text in order to understand the legal ramifications of operating a hot tub for a diving program. Other individuals besides those in the diving program may have access to the facility which may increase risks.

## PHYSICAL HAZARDS

The main physical hazards of spa usage have been identified by the Consumer Product Safety Commission through its National Electronic Injury Surveillance System (NEISS). They include drowning, falls and electrocution. An average of over 1,000 spa accident victims have been treated in hospital emergency rooms annually since 1980 (Johnson, 1994).

Drownings are frequently caused by alcohol, the body's reaction to hot water, hair entanglement in bottom drains, and falling unconscious into the spa after striking the head. Electrocution usually involves use of electrical appliances such as radios, CD or audio tape players and VCRs near the spa. Human factor analysis of spa accidents shows that victims who had consumed alcohol had blood alcohol levels ranging from .09% to .42% (in most states, the blood-alcohol limit for driving is .10%). Water temperatures often ranged from 106° F to 114° F (the absolute maximum permissible water temperature is 104° F). In addition, up to one-third of those who died in spa accidents were alone at the time of the accident.

The conclusive case against alcohol consumption in the aquatic environment has been proven. Nevertheless, there is still a widespread rationalization by many recreational pool users that a few drinks are somehow 'OK.' All aquatics-related professionals should be informed about this issue to give effective leadership in community campaigns targeting recreational pool users to increase awareness of this hazard. It is potentially very dangerous to use alcohol, tranquilizers or sedatives before soaking in a spa or hot tub. Hot water can increase the substance's muscle relaxant effects, give a general sense of enervation and produce substantial weakness. Some people become drowsy enough to lose track of time and stay in too long. Alcohol, when consumed before or during hot-water immersion, can lead to serious chemical imbalances, as it ultimately promotes sweating. Alcohol is also a diuretic and

can increase the loss of trace minerals, such as potassium, which regulate heartbeat and other bodily functions. For the same reason, individuals taking diuretics should also use spas with caution.

Recommended times for length of stay in spas and hot tubs vary according to water temperature. Generally, at 98° F, no limit is necessary, and length of stay can be determined by individual discretion and tolerance. **At temperatures between 100 and 104° F, most health and medical authorities recommend a maximum stay of 12 to 20 minutes.** At higher water temperatures (104° F and above), there is a significant element of danger, which grows in proportion to increasing water temperature and seriousness of health conditions. Reddening skin or dizziness is a definite sign that it is a time to get out of the tub at any temperature.

A precautionary sign against overuse of the spa should be posted conspicuously near the tub. Accompanying this notice should be a warning that long exposure may lead to dizziness, resulting in such problems as impaired judgment and vision.

The following list of rules is suggested for spas:

## CAUTION

1. Take a soap shower before entering the spa.
2. Enter and exit the spa slowly and cautiously.
3. Persons in the following categories should not use the spa, as they will place themselves in physical danger:
  - Those with heart disease, diabetes, emotional disorders, high or low blood pressure, circulatory deficiencies, hypertension, stress problems, seizures and epilepsy.
  - Those who are on diets or are using prescribed or recreational drugs.
4. Pregnant women are permitted to use the spa for up to 15 minutes if the temperature is below 102° F. At temperatures above 102° F, damage to the fetus may occur.
5. Unsupervised use by children is prohibited.
6. Children under 5 are not permitted to use the spa because their thermoregulatory mechanism is not fully developed and brain damage may result from prolonged immersion.
7. Do not use the spa while under the influence of alcohol, anticoagulants, antihistamines, vasoconstrictors, vasodilators, stimulants, hypnotics, narcotics or tranquilizers.
8. Never use the spa alone.
9. No diving or jumping into the spa.

10. Observe a reasonable time limit (10 min.); then shower, cool down, and if you wish, return for another brief stay. Long exposure may result in nausea, dizziness or fainting.
11. Use of body lotions, oils or suntan preparations is prohibited.
12. Street shoes may not be worn in the spa area.
13. No food or drink is permitted.
14. Do not submerge to the bottom of the spa, as hair may become entangled in the drain.
15. Do not exercise aerobically in the spa. Stretching exercises are permitted.
16. Failure to follow these rules may result in serious injury or death.

Check your state health codes for additional safety requirements.

When an outdoor spa is not in use it should be covered. A cover serves as protection against unauthorized use and accidental falls and may also help to retain heat in the water. Covers are less important for indoor spas because access is more easily controlled and indoor temperatures are likely to be high enough to hold heat loss down.

## HEALTH AND DISEASE HAZARDS

While hot tubs help the diver retain body heat, they can have harmful effects on the body under some conditions. They can be a breeding ground for bacteria. Hot water, high-density usage, low disinfectant levels and infrequent draining provide an excellent environment in which bacteria may grow. User density is a little-understood factor until spa use is compared with swimming pool use. Two people in a 400-gal. capacity spa are equivalent to 1,050 people immersed in a swimming pool 75 ft. by 45 ft. with a 210,000 gal. capacity. Inattention to disinfectant levels and infrequent draining and refilling are the two primary reasons for outbreaks of spa-related diseases.

### Health-related Problems

A serious problem related to spa misuse is hyperthermia, with symptoms including headaches and dizziness. Some people like to exercise in hot water, but they should be aware that once the surrounding water temperature rises to 85 to 90° F., they are risking hyperthermia. When the body temperature increases to 110° F. from exercise or prolonged immersion (beyond 15 min.), the metabolic rate increases, the brain becomes greatly depressed, sweating decreases and heat stroke may result.

A person who has sustained any type of injury that is treated with ice, such as a sprain, should avoid the spa. Hot water may increase swelling and delay recovery.

Another non-disease-related spa problem is dermatosis or folliculitis. About 5% of spa users develop a skin rash from spas that utilize bromine as a disinfectant. While the reaction is not believed to be serious, a physician should be consulted if a rash occurs. Antibiotic treatment may be necessary.

Coughing disease, a nonbacterial problem that causes coughing spells and irritation to the respiratory system, may

result from poor ventilation in the spa area. The spa disinfectant and nitrogen-ammonia compounds vaporizing at the water's surface irritate the mucous membranes of the nose and throat, resulting in coughing until the person leaves the spa area.

### Disease-related Problems

Because hot water is conducive to the growth of disease-producing microorganisms, a wide variety of diseases can be contracted from improperly maintained spas. Common problems range from staph infection, which cause boils, to vaginitis and urinary tract infections. Other, more serious diseases that occur with some frequency include Pontiac fever and hot tub folliculitis. **At this time, the medical profession does not believe that AIDS can be transmitted through spa or hot tub water, as the virus is extremely susceptible even to low levels of chlorine and bromine disinfectants. It is also believed that the virus cannot exist outside the human body.**

Pontiac fever is a hot-water disease with flu-like symptoms. Nausea, dizziness, headache, vomiting and fever are the prominent symptoms. The bacterium responsible for Pontiac fever (*Legionella pneumophila*) is the one that causes Legionnaires' disease, which can likewise be transmitted in spas and hot tubs.

**Hot tub folliculitis (caused by *Pseudomonas aeruginosa*) is another common spa disease.** Bacteria are carried on the skin and enter the water when users fail to shower before entering the spa. Heat dilates the pores and the inlet jets jackhammer the skin, forcing bacteria into the pores. The symptoms, which usually begin to appear within 24 hours, consist of fatigue, swollen lymph glands, redness, tenderness, swelling of the breasts (in both men and women), and open pustule-type sores that ooze, itch and then turn painful. Blood poisoning, urinary tract infection and pneumonia may result. While the illness usually runs its course in seven days, it can last as long as two to three weeks.

**Spa water should be tested weekly for the presence of *Pseudomonas*;** testing should be done at least once a week during heavy use periods. Coliform bacteria are also found in hot tubs. Coliform tests should also be conducted at least once a week.

In most situations, the aquatics director is responsible for maintaining proper disinfection of the spa; however, the diving coach needs to understand the hazards related to improper use and maintenance. By understanding the hazards, the coach is more likely to prevent injury or illness related to spa use. If the diving coach is responsible for maintaining the spa/hot tub for the divers, it is highly recommended that he/she receive training relating to swimming pool and spa operation. The YMCA of the USA offers a course, "Pool Operator On Location", which provides the training necessary for safe operation of swimming pools and spas.

## **SUMMARY**

Spas and hot tubs are becoming commonplace at competitive diving facilities. There are a variety of risks related to hot water immersion. Provide proper maintenance and supervision of the spa or hot tub. Post rules and regulations governing the use of the spa.

Knowledge of the health-related issues will assist in maintaining a healthy environment for the divers and coach. All of the maladies addressed in this chapter are preventable. Protect your diving team and others who may use the facility through conscientious efforts to provide a healthy environment.

## **REFERENCES**

Johnson RL (1994) YMCA Pool Operations Manual. Champaign, IL: Human Kinetics Publishers.

# Part 5. Gymnastic Mats in Diving Programs

by Dan Copeland

## DRY LAND TRAINING FOR CONDITIONING AND TEACHING BASIC TUMBLING AND/OR SOMERSAULTING SKILLS

In this training situation, basic gymnastics skills such as armstands, forward/backward rolls, front/back handsprings and front/back somersaults are performed. The intent of this type of training is:

(1) To build the diver's endurance by performing skills such as front/back handsprings in succession.

(2) To teach body awareness, basic tumbling and somersaulting skills to the beginning diver progressing from the simple (forward/backward rolls) to the more complex (front/back somersaulting skills), progressing in difficulty from the tuck to the pike to the straight position, and from non-twisting somersaults to somersaults with twist(s). No head-first dives should be simulated into gymnastic mats. Only feet-first landings are permitted.

This type of dry land training is identical to the training curriculum used by gymnastics coaches/instructors to condition and teach body awareness and basic tumbling skills to young gymnasts. Therefore, the basic safety guidelines, as they apply to the use of landing mats established for the sport of gymnastics, directly corresponds to their use in this type of dry land training. First and foremost of these guidelines is the understanding and appreciation by all of those who are participating in any gymnastics activity that:

**EVEN WHEN PROPERLY USED, GYMNASTICS MATS ARE DESIGNED TO REDUCE THE RISK OF INJURIES – NOT TOTALLY ELIMINATE THEM. THE ASSUMPTION THAT A MAT MANUFACTURER CAN DESIGN, CONSTRUCT AND PROVIDE A FAIL-SAFE MAT THAT ELIMINATES THE POSSIBILITY OF SERIOUS INJURY TO THE DIVER CREATES A TRAINING ATMOSPHERE CONDUCTIVE TO SERIOUS INJURY, INCLUDING PERMANENT DISABILITY AND DEATH.**

This assumption virtually ignores literally hundreds of other factors that must be considered when correctly assessing diver safety.

Gymnastics mats must remain only one of the many elements involved when analyzing diver safety. A check list of other key factors that must be taken into consideration are:

(1) the conduct of those participating in the activities, (2) the readiness of the performer, both physically and mentally, (3) the nature and condition of the apparatus on which the skills are being performed, (4) the nature and condition of the area or facility in which the activities are performed, (5) the amount, degree and quality of supervision being exercised over those divers participating in the gymnastics-like activity, and (6) the competency of the diving coach. All of these factors must be taken into consideration along with many other factors that can arise in each unique situation, such as diving dry land training, in which gymnastics activities occur.

While they are only one of many elements involved in diver safety, properly used gymnastics mats do offer the diver a limited amount of protection against injury. However, there are many key factors that must be considered when analyzing the effectiveness of gymnastics mats.

These key factors include: (1) the selection of appropriate matting for each particular activity, (2) The manufacturer's intended use of each mat, (3) the physical condition of each mat, and 4) the installation, care and maintenance of each mat.

## SELECTION

The selection of appropriate matting is an important element in diver safety, and therefore should be considered thoroughly. Key considerations in the process of mat selection include:

(1) **The difficulty of the skills performed.** As the degree of difficulty increases or decreases with each of the different skills performed, the risk factor for each individual diver increases or decreases. Therefore, appropriate matting requirements will change as the risk factor for each skill and each diver increases or decreases.

(2) **The age and existing skill development level of the diver.** The skill development level of each participant, which can be a function of the participant's age and fitness level, not only determines the ease or difficulty with which skills are performed, but many times will dictate which skills are attempted. Therefore, appropriate matting requirements can vary with each diver and with each skill being performed.

(3) **The continuing effectiveness of the mats themselves given proper installation, care and maintenance.** Gymnastics mats, like any other item that is purchased and routinely used, are subject to normal wear and tear, and ultimately obsolescence. Moreover, the awareness that:

**EVEN AN EFFECTIVE MAT CAN OFFER ONLY A REDUCTION OF RISK FROM INJURY, AND THE USE OF A NON-EFFECTIVE MAT IS DANGEROUS AND CAN ACTUALLY CONTRIBUTE TO THE SEVERITY OF INJURY SHOULD ALSO BE CONSIDERED.**

The decision as to whether a gymnastics mat is effective or ineffective must lie with the individual who is selecting a particular mat for a particular purpose. Several factors that should be considered are:

**The age of the mat.** While the age of the mat is an important consideration, it cannot be the only one. Because mat manufacturers cannot control the amount or type of use that each mat receives, a universal life expectancy for each particular mat cannot be established.

**The condition of the foam in the mat.** (1) After use, the soft sponge-like foam in gymnastics mats may begin to breakdown. This breakdown may take the form of flaking, in which very small pieces of foam simply disintegrate or separate from the main body of foam. Any landing or fall onto a mat in this condition can create a “**bottoming out**” effect resulting in serious injury. (2) The firm resilient foam in gymnastics mats is also subject to deterioration, in which the foam compresses and remains compressed rather than returning to its original position. This creates a very hard and thin working surface, and therefore can also contribute to serious injury.

**The physical condition of the mat covering.** The use of mats with torn or worn out coverings can contribute to serious injury. Defective mat coverings should be repaired or replaced immediately.

In summary, the continued effectiveness of any type of gymnastics mat varies greatly. Therefore, it is recommended that careful inspection of all gymnastics mats be done on a regular basis. The effectiveness or ineffectiveness of each mat must be determined by the individual(s) selecting and/or using the mat(s).

## **GYMNASTIC MAT CHARACTERISTICS**

In general, mats have one of two potential characteristics. They will either be primarily **resilient** and return quickly to their original position after compression (referred to as “**memory**”), or they will be primarily **shock absorbent**. To a large extent, the mat material itself determines its characteristic quality. An example of this difference can be seen in the use of closed-cell foam in basic mats to open-cell foam used in landing mats and skill cushions. While both types of foams are similar in that they incorporate thousands of small cells filled with air, their differences lie in each cell’s ability to either hold air or allow it to escape when compressed. The **closed-cell foam** does not allow the air trapped in each cell to escape.

Therefore, its ability to be compressed is limited and, as such, is quick to return to its original position. The use of this closed cell foam in basic mats creates a firm, resilient working surface. In contrast, the **open-cell** foam used in landing mats and skill cushions does allow the air trapped in each cell to escape when compressed. Therefore, the use of open-cell foam in these mats creates a softer, more shock absorbent working surface. Obviously, most mat materials will have both resilient and shock absorbent qualities. However, materials vary to the degree that they are either resilient or shock absorbent.

## **GENERAL INFORMATION FOR SELECTION**

**Mats should be selected both in terms of their functional suitability and also in terms of durability and hygiene.** If the covering and cushioning materials are resistant to water, rotting and bacterial growth will be inhibited. This aspect should be considered carefully if you are setting up this training station outdoors by the pool area. Most mats are enclosed in fabric envelopes, although some basic mats have painted exterior surfaces. Mat covers should give good traction, be in colors that provide visual contrasts, and fit tightly. Stitches should be made with durable thread and in places with minimal impact by the divers. Mat covers should be easy to clean, repair and remove when replacement of cushioning materials is necessary.

## **INSTALLATION**

Supports and building obstructions should be covered by mats, properly cut when necessary. Lumps and gaps should be avoided. Basic mats should not overlap. Special mats and landing mats should be placed over basic mats when appropriate.

## **CARE**

Gymnastics mats should **ONLY** be used for gymnastics and gymnastics-like activities, and therefore the guidelines established in this article as they relate to diving dry land training should be carefully considered.

Walking on mats with improper footwear should be discouraged. Preventative maintenance will prolong the lives of mats and make them softer. When mats are cleaned with soap or disinfectant, they should be wiped with clear water and dried thoroughly.

## **MAINTENANCE**

Mats should be cleaned and repaired at regular intervals. Stitching should receive particular attention. Torn covers should be repaired or replaced. Cushioning materials should be selected not only in terms of their functional suitability but also in terms of their durability. A record should be kept of the original purchase and repair dates.

## FEATURES AND INTENDED USES OF GYMNASTIC MATS

The use of these mats for any purpose other than their intended use can result in serious injuries including permanent disability and death. No head-first dives should be simulated into basic mats, landing mats and/or skill cushions.

TYPE	FEATURES	INTENDED USE	CAUTION*
<b>BASIC MATS</b>	Constructed of a single layer of closed-cell resilient foam <b>ranging in thickness from 1 to 2.5 inches.</b>	Designed and constructed to provide a resilient floor covering. <b>(1) To provide a resilient working surface on which tumbling skills can be performed</b> including basic tumbling skills such as front/back handsprings both stationary and in succession and front/back somersaults initiated from the floor either stationary, or following skills such as a round off or front/back hand-spring.  <b>(2) To be used underneath landing mats to provide an additional layer of cushioning material between the floor and landing mat.</b>	Because of their <b>lack of shock absorbent qualities</b> , basic mats, when used solely as landing mats, <b>DO NOT</b> adequately protect the diver against injury from skills initiated from any surface (eg. trampolines, dry land springboards, etc.) other than the basic mat or floor.
<b>LANDING MATS</b>	Constructed of one or two layers of resilient foam combined with a single layer of softer, more shock absorbent, open-cell foam, and <b>range in thickness from 3 to approximately 7 inches.</b>	The design and construction of these mats using the softer more shock absorbent foam underneath, or sandwiched between, the resilient closed-cell foam creates a firm, yet shock absorbent, landing surface. The application and/or use of landing mats for the diving dry land training situation is consistent with their intended use in the men's and women's floor exercise event in gymnastics. (The intended use of these landing mats for areas around and underneath men's and women's gymnastic apparatus does not apply to their use in the diving dryland training situation.) <b>Landing mats can be used to cushion the landings of various tumbling skills.</b>	Landing mats do not possess the resilient qualities that are found in basic mats, and therefore should <b>NOT</b> be used as a tumbling surface <b>OR</b> as a surface from which tumbling skills are initiated. The restrictions or recommended use for tumbling skills lies in the positioning of the landing mats.
<b>SKILL CUSHIONS</b>	Often times vinyl covered mats filled only with the soft, open-celled, shock absorbent foam, and <b>range in thickness from 8 to 12 inches.</b>	Originally designed for younger children's physical education activity programs, these mats provide a softer landing surface than do landing mats. These mats can also be used when a diver is attempting a new or difficult skill in an effort to reduce the risk of injury when landing in an off-balance position.	Should <b>NOT</b> be used as a tumbling surface <b>OR</b> as a surface from which tumbling skills are initiated.

**CAUTION\*:** It must be clearly understood that gymnastics mats, no matter how thick or what type of foam is used, are not the complete answer to reducing or eliminating injuries. While the softer, more shock absorbent mats do offer more protection to the diver for landing, there still must reach a point where the compression of the mat must stop. Therefore, regardless of the type or thickness of the mat(s) used, any landing on the head, neck, or in an off-balance position must be avoided at all costs. Any falls of this nature can result in serious injury, including disability and death. No head-first dives should be simulated into basic mats, landing mats or skill cushions.

## **AREAS OF CONCERN**

- Basic mats should not overlap. Velcro flaps attach one mat to another.
- Most mats use plastic materials. When they burn toxic gases are produced.
- Basic mats, landing mats and/or skill cushions should not be used in dry board or dry platform training as a landing surface in the place of a landing pit or on top of a landing pit to create a more stable landing surface. This is not the intended use of these mats, and thus using them in this fashion can result in serious injury, including permanent disability and death.

## **REFERENCES**

- Copeland D (1985) Gymnastic mats. In GS George (ed.): USGF Safety Manual. Indianapolis, IN: The USGF Publications Department, pp. 43-49.
- Whitlock S (1998) USA Gymnastics Safety Handbook. Indianapolis, IN: USA Gymnastics Publications, pp. 25-28.

# Part 6. Use of Portable Landing Pits for Dry land Diving Training

by John F. Salvo, M.S.

The in-flight body awareness and spatial orientation required of a diver can only be developed by a repetition of training in the air. Such “air time” training can be significantly enhanced by the utilization of an above ground level portable training pit system.

A portable landing pit used in concert with an overhead safety belt can create an optimum learning environment for young divers. However, as with any teaching tool, this type of mat system should be used under the careful guidance and supervision of a trained professional instructor. Competent coaching procedures dictate that prudent teaching progressions always be used. Common sense and good judgment must prevail. Most definitely, **HEAD-FIRST LANDINGS SHOULD BE AVOIDED IN ALL TRAINING UTILIZING A PORTABLE LANDING PIT.** The overhead mounted spotting rig does, however, enable a competent spotter to assist the diver in a safety belt to the hands in an armstand landing position, which simulates head-first water entry alignment of the diver with arms overhead. The spotter then controls the diver down to the pit.

## REQUIREMENTS

A portable landing pit used for dry land training of complex diving skills should meet certain requirements. These requirements have to do specifically with: (1) location in the training area, (2) materials used in construction of the portable landing pit, and (3) dimensional parameters.

### LOCATION

Special attention should be paid to the location of the portable landing pit, both when in use and when in storage. The pit’s proximity to the pool, deck and moisture in general should be of particular concern. To be sure, water and exposed polyurethane foam do not co-habitate well, since direct introduction of water into the portable landing pit can seriously compromise the integrity of the cell structure in the polyurethane foam. Remember, this is a dry land training tool!

## MATERIALS

### Encasement

As an aid to moisture repulsion and to overall strength of the portable landing pit, the encasement or cover of the unit should be constructed from a heavy gauge vinyl-coated nylon fabric. Specifically on the bottom and sides of the pit, this encasement must be fabricated in a solid and water-impermeable vinyl fabric in order to preclude any moisture penetration and thus protect the internal polyurethane foam structure from damage.

The top section of the portable landing pit unit must be constructed by using a vinyl-coated nylon breather or mesh - type material. This breather fabric will allow an adequate escape of air through the pit’s top surfaces. Such air flow in the pit unit is critical to the mat’s desired performance and landing characteristics. This is so because the ability of the portable landing pit to safely decelerate a diver’s body in motion is best achieved through a successful integration of polyurethane foam and rapidly escaping air flow.

To summarize the purpose of the portable landing pit’s encasement, one can simply state that the encasement must act as the unit’s outer membrane or skin. This membrane protects the internal polyurethane foam from moisture penetration and from subsequent foam cell structure failure that water introduction can wreak on the polyurethane. When training takes place on the portable landing pit, the encasement must at the same time allow, via the breather fabric, an exit path for air expulsion during diver deceleration. Finally, the encasement must contain and protect the foam from foreign object intrusions and damage during storage and training; and to facilitate that storage and training, it should provide handles for ease of portability.

### Shock absorption

The performance of a portable landing pit is determined by the combination of high quality shock absorbing polyurethane foam and that foam’s construction in a lattice or honeycomb formation. The lattice network forces corridors of rapidly escaping air to be tunneled to the surface, thus causing the controlled deceleration of the diver.

The portable landing pit’s ability to continue shock absorption through its layers is largely due to two factors. The first is the inherent capacity of the cell structure in the polyurethane foam to absorb energy. The second factor is the air flow and its attendant deceleration properties.

The synthetic polyurethane foam used in portable landing pits are made up of tiny cells. These cells store air inside their membranes and, when compressed, forfeit this air. This process of forfeiting the captured air in the polyurethane foam material is what creates the shock absorption characteristics needed for safe landings.

### Air flow

The air flow of a portable landing pit is created in large part by way of the corridors built into the design of the portable landing pit. Planks of polyurethane foam are fabricated in such a manner as to form a crisscross or lattice structure. Inherent in this lattice structure are caverns which produce

the tunneling corridors essential for forcing the air out of the system.

When the planks of foam constructed to form the walls of these corridors break down, obstruction of air flow occurs. This obstruction causes an improper or insufficient volume of air flowing through the system. The result is a loss of the necessary deceleration qualities and consequent reduction of the shock absorption characteristics required for safe landings. Here again, the use of good quality polyurethane foam in the portable landing pit's construction will retard the inevitable foam plank deterioration that causes such system failure.

### Test for fatigue

When compression is removed from the portable landing pits, the cells immediately draw air back into their membranes. This process is commonly referred to as "foam memory." The cells are "remembering" their pre-compression shape and form. Once the cells have drawn in the necessary air, they are again loaded and ready to absorb energy.

**The cells can, after time, fatigue and lose their ability to reload with air after compression. At that time, the landing pit foam should be replaced with new foam.** The use of a high resiliency prime polyurethane foam is essential to the longevity of the landing pit. Such a system will fulfill its training mission for many years if fabricated of foam which meets very high standards.

### DIMENSIONS

The size of the portable landing pit is very important to the overall success of dry land training programs, since a large portable landing pit will elicit a feeling of confidence from young divers. A confident diver will be more inclined to strive for improvement. With an appropriate portable landing pit, you should be able to furnish that diver with a wealth of repetitions in a safe, dry environment.

In order to ascertain appropriate size for a portable landing pit, a few simple guidelines should be followed. A diving dry board propels a diver up and forward into the air. So, the portable landing pit must be constructed to provide a sufficiently large landing area.

### Length

**A 12 feet minimum forward distance is recommended** with 16 to 18 feet considered an average forward distance.

### Width

One must take into account the potential for lateral drifting from improper take-offs when determining the appropriate width of a portable landing pit. Based on this consideration, a 7 feet minimum is recommended, with 8 to 10 feet considered an average width. However, in U.S. Diving programs, twisting skills on the dry board are performed in the overhead mounted spotting belts which controls lateral

displacement. Therefore, **U.S. Diving recommends a minimum width of 6 feet** that provides a minimum recommended landing pit area comparable to the size of the minimum recommended trampoline bed 6 feet x 12 feet).

### Depth

The depth, or "floor to top" of the portable landing pit should be a **minimum of 32 inches** in order appropriately to decelerate the diver's body. Greater depths of 36, 39, and up to 42 inches are also available. The deeper the pit, the more foam and air available to continue the shock absorption and to provide for a safer landing from greater heights.

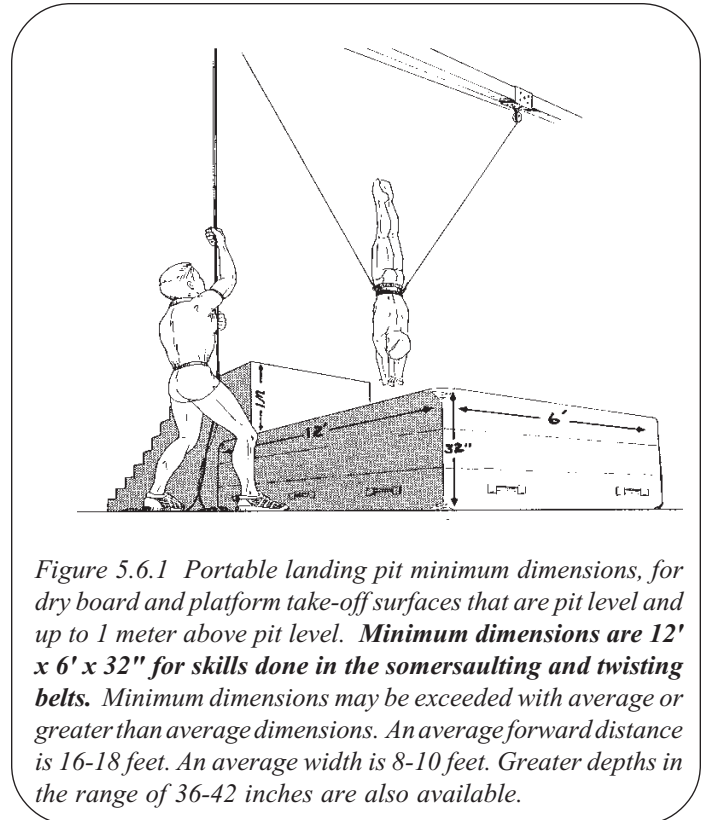

*Figure 5.6.1 Portable landing pit minimum dimensions, for dry board and platform take-off surfaces that are pit level and up to 1 meter above pit level. **Minimum dimensions are 12' x 6' x 32"** for skills done in the somersaulting and twisting belts. Minimum dimensions may be exceeded with average or greater than average dimensions. An average forward distance is 16-18 feet. An average width is 8-10 feet. Greater depths in the range of 36-42 inches are also available.*

### GUIDELINES

It is the coach's responsibility as a professional in the instruction of diving to provide a safe and appropriate learning environment for the divers. To do so when using an above ground portable landing pit, follow good judgment in choosing progressions that are appropriate to the skills to be mastered. Moreover, make totally certain that the portable landing pit is of sufficient dimensional proportions for the size of the diver, the level of skill to be learned, and the appropriateness of spotting. Finally, always take proper steps to check that the portable landing pit is functioning at a high level of shock absorption and that it is maintained in an acceptable, safe condition.

### REFERENCES

Salvo JF (1990) Use of portable landing pits for dry land diving training. In Gabriel JL and George GS (eds): U.S. Diving Safety Manual. Indianapolis, IN: U.S. Diving Publications, pp. 65-67.

# Part 7. Diving Training Stations and Spotting Rigs for Trampoline, Dry board, Dry Platform and Wet board

by Dick Kimball, M.A.

There are four stations commonly used in competitive diving training in conjunction with an overhead spotting rig and belt: trampoline, dry board, dry platform and wet board. The coach controlling the ropes assists the diver to perform the mechanics correctly and lands the diver safely. With a competent spotter controlling the ropes, the use of these stations increases the likelihood of a positive learning experience for the diver. Repetition of success in the spotting belt fosters a positive perceived competence in divers. Each station has a unique contribution to athlete preparation.

## DRYLAND TRAINING STATIONS

Three dryland training stations are commonly used with overhead belt spotting: trampoline, dry board and dry platform. At these dryland stations, overhead belt spotting provides the opportunity for the diver to enhance spatial orientation, visual spotting and technique while performing in a safety belt. Safe landings are controlled to the feet, to a basic trampoline drop position or to the hands in an armstand (see Figure 7.4.7 p. 113). Rehearsing head-first entry in the belt at these stations enables a positive transfer of learning when dives are performed in the pool.

## TRAMPOLINE

The trampoline with overhead belt spotting enables divers to practice many repetitions of a skill without having to get wet or climb back up onto the board. It is the most common dryland training station used for teaching spatial orientation, visual spotting and comeout techniques in the various dive groups.

## Safety Record

Diving coaches have traditionally used the trampoline for diving training in a unique and safe manner while realizing its full value as a teaching and training aid. NCAA diving coaches studied in the Big Ten Conference in 1978 had been connected with their respective conference schools for a total of 90 years. Counting each diver in each of those years, these coaches have coached approximately 12,000 divers including varsity, summer camp and age group. The trampoline had been an important part of the development of these divers, yet there had been only one fracture of any kind and no paralysis during this time. Vigilant supervision of the trampoline is a key factor in providing a safe and successful learning environment (Clarke, 1978). Today trampoline is included in U. S. Diving insurance as a training station. **There is no record of a fatality or serious spinal cord injury in a U.S. Diving competitive program** (Gabriel, 1992; Clarke, in progress).

## Sport Specific Trampoline Use

In accordance with the **principle of specificity of training**, diving skills on trampoline are practiced as single contact activities (i.e. one skill at a time) to simulate take-offs and flight into the pool. When using the trampoline as a training station in competitive diving, take-offs are initiated by no bounce, a step-in hurdle, “priming” the bed while standing or by using several low bounces. The purpose of the low bounces is to enable sufficient height to execute and land the skill on the trampoline bed which, unlike a springboard over water, is the same height on both take-off and landing.

**Step-in hurdle.** The step-in hurdle begins from the edge of the trampoline bed or by standing on the frame pad. The step-in hurdle is used for practicing the hurdle technique and is used in combination with aerial skills for the forward and reverse dive groups to practice the take-off. This abbreviated version of the approach is used on the trampoline instead of the full forward approach to allow the diver to execute the aerial maneuvers safely in the middle of the trampoline. Since more than one jump on a running approach in competitive diving is judged as a failed dive, using a step-in hurdle is a more sport specific application on trampoline than using several low bounces.

**Standing back take-off.** Dives from the backward and inward dive groups are generally practiced without bounces when possible. “Priming” the trampoline bed simulates “oscillating” the diving board.

## U.S. DIVING TRAMPOLINE EQUIPMENT SPECIFICATIONS

### Trampoline Bed

•The following dimensions of the bed under tension, ready for use are recommended:

- 5 ft x 10 ft
- 6 ft x 12 ft
- 7 ft x 14 ft

•Minitramps are not covered by U.S. Diving accident or liability insurance.

•The bed must be strong enough to withstand wear, and not tear when in use. Upon inspection, if any tear is noticeable in the bed, the trampoline must be taken out of service.

•The center of the bed must be indicated.

### Area Free of Obstruction Beneath the Bed

- The height of the bed from the floor shall be determined by the manufacturer and must be sufficient to prevent the bed from contacting the ground or floor while bouncing.

- Obstacles must not be placed under the trampoline when in use.

- The trampoline must be constructed so that the competitor will not touch any part of the frame beneath the bed.

### Suspension

- The bed must be suspended with springs in such a way as to present no danger to users.

### Safety Padding

- The frame and springs must be entirely covered by a shock absorbent padding. The padding should be firmly fixed to the frame.

### Overhead Clearance

Verify that the area overhead to be used is free of overhead obstructions and is suitable for this type of activity. For example, lighting fixtures, climate control mechanisms, beams, scoreboards, etc. should be located elsewhere. The amount of overhead clearance needed on a trampoline depends on how the trampoline is used. Diving coaches should be aware that the international governing body for competitive trampoline (FIG) recommends 24 feet overhead clearance for competitive trampoline routines on an FIG approved string bed or 5.5 mm web constructed bed. The American Society for Testing and Materials (ASTM) recommends 24 feet overhead clearance for trampolines used by consumers in home environments (F381-99). The intended use of the consumer trampoline is for the purpose of continuous, vertical jumping activities.

- U.S. Diving recommends at least a minimum 17 feet, to a preferred 21 feet, floor to pulley overhead clearance (see Figure 5.7.1) for diving specific usage of the trampoline (i.e. single contact activities (dives) priming the bed and low preliminary bounces) and to accommodate the placement of a spotting rig crossbar so that somersaulting and twisting skills may be performed in the overhead safety belt.

### Placement

- Place the trampoline on a level surface before use.

### Care and Maintenance

- Secure the trampoline against unauthorized and unsupervised use.

- Follow trampoline care and maintenance instructions supplied by the manufacturer.

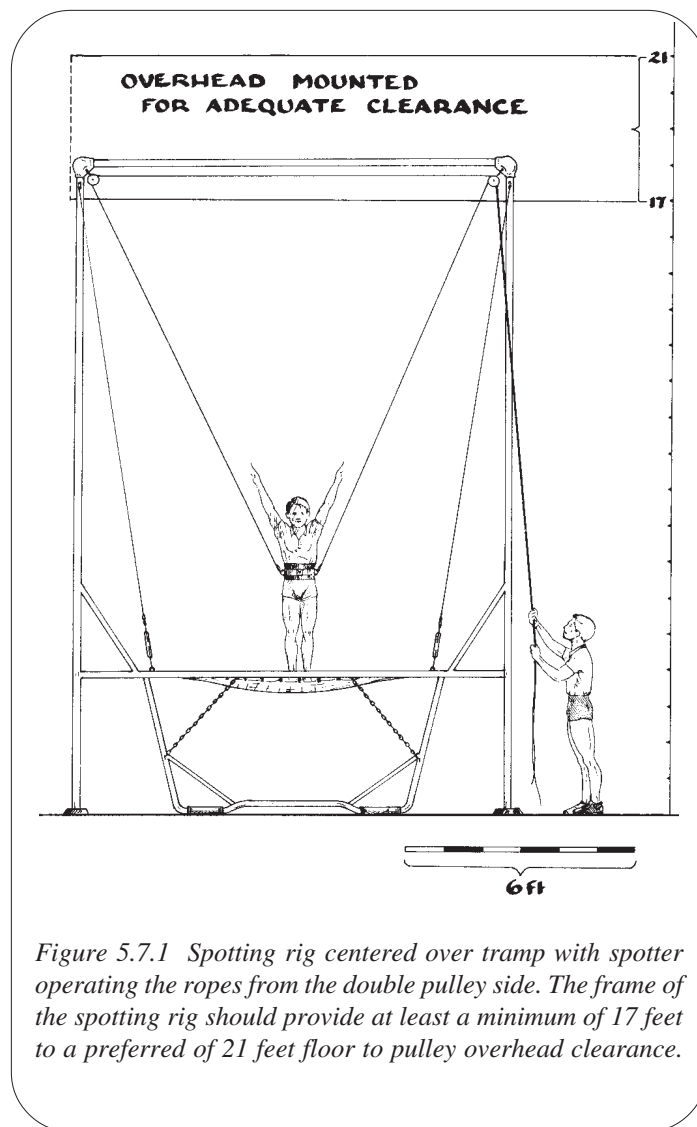

Figure 5.7.1 Spotting rig centered over tramp with spotter operating the ropes from the double pulley side. The frame of the spotting rig should provide at least a minimum of 17 feet to a preferred of 21 feet floor to pulley overhead clearance.

### DRY BOARD/PLATFORM WITH PORTABLE LANDING PIT

On trampoline the diver does not have to contend with the presence of the diving board. The dry land springboard and portable landing pit with an overhead spotting system provides a training station with more specificity than the trampoline. The dry board take-offs exactly simulate the take-offs from the board in the pool. When a diver does an inward or reverse take-off on dry land board, the same psychological feeling is experienced in the pool.

### Clearance

Since most dry board with portable landing pit training stations are not designed as competitive equipment, it is important that coaches modify the activity so that the safety of the diver is not compromised. **On dry board, no multiple bouncing, somersaulting or twisting is allowed out of the belt.**

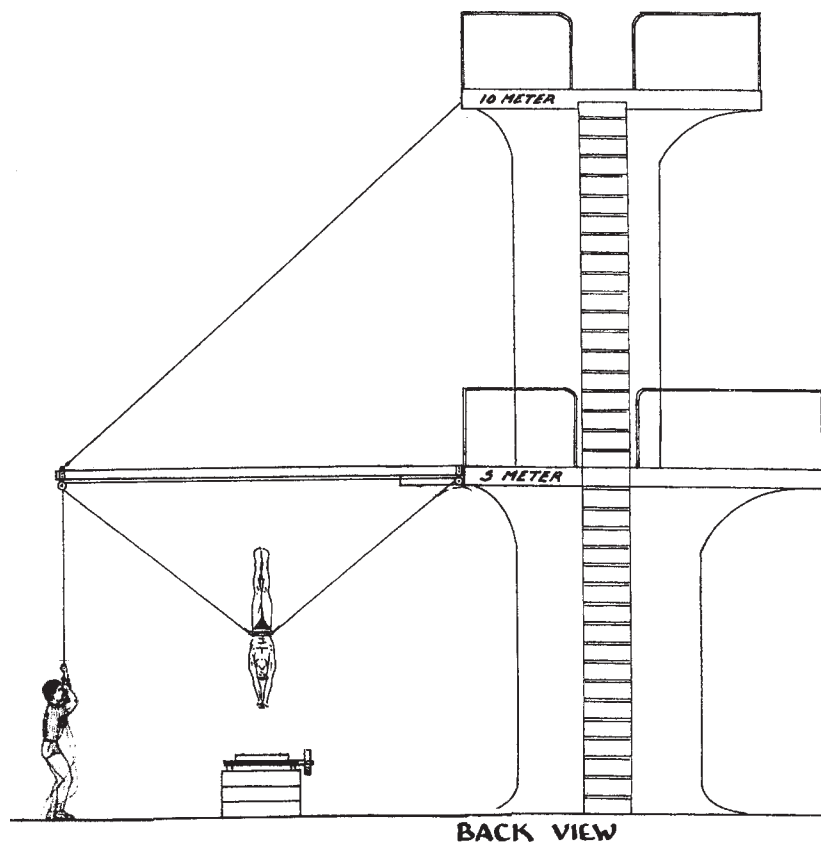

Figure 5.7.2 Spotting rig mounted over the water above the 1-meter wet board

## WET BOARD

The overhead belt may also be used very successfully when mounted over the water above the 1-meter board, in the pool itself (see Figure 5.7.2). Using the wet board station enables the diver to experience a successful first attempt of a new dive into the water. The technique of spotting is the same as that used on the dry land board on take-off. By varying the timing of the assists the coach may use the 1-meter wet board station to prepare the diver for a 1- or a 3-meter dive. Likewise 3-meter wet board station may be used to prepare the diver for a 3- or 10-meter dive. After the diver comes out of the dive, the spotter lets the ropes slide through his/her hands while the diver makes the entry into the water.

## Overhead Clearance

FINA Dimension (G) recommends 5 meters overhead clearance above a 1-meter. With the overhead spotting rig in place, in many facilities, coaches may need to prohibit multiple bouncing of the board out of the belt. Provision should be made for at least ten extra feet of ropes so that when the rope is released for entry, it will not be pulled through the overhead pulleys.

## Care and Maintenance of the Training Stations

Trampolines, dry boards and wet boards should be maintained according to the manufacturer's specifications. Dry platforms should be checked to see that the surface is level, rigid and non-slip.

## OVERHEAD MOUNTED PULLEY RIG

There are several ways to mount an overhead pulley system over the different types of equipment used for diving training. A spotting rig may be mounted on the ceiling or directly to the frame of the trampoline. The first step is to select a site which allows for adequate floor to ceiling overhead clearance. Then have a reputable architect or engineer verify in writing that the surface upon which the system will be mounted possesses sufficient structural integrity to withstand the repeated forces characteristic of its intended use.

### Rope

Cotton hemp rope provides a safe, sure grip for the spotter and prevents abrasions, but will wear out rapidly if used constantly. Nylon rope has the advantage of being more durable but it is harder on the spotter's hands. A braided dacryon rope seems to work well for most diving coaches. A rope diameter of 3/8 inch is generally used, but there are coaches who have a preference for a 1/2 inch rope.

### Ceiling clamps and pulleys

Overhead spotting rigs require the use of appropriate ceiling clamps for proper mounting of the pulley system. These can be obtained from most major gymnastics equipment manufacturers. The appropriate size and style of ceiling clamps depend on the exact type and size of the ceiling anchor point material (Milem, 1990).

Pulleys may be hooked to the ceiling or mounted in a tree over the trampoline--or in any other way that is structurally secure. For example, pulleys being hooked to beams are feasible with special I-beam clamps which may be purchased. The type of pulley used may also vary. Pulleys with a sliding bearing around the pin are preferable for longevity. A four inch wooden pulley works well. A single and double pulley arrangement is necessary (see Figure 5.7.3).

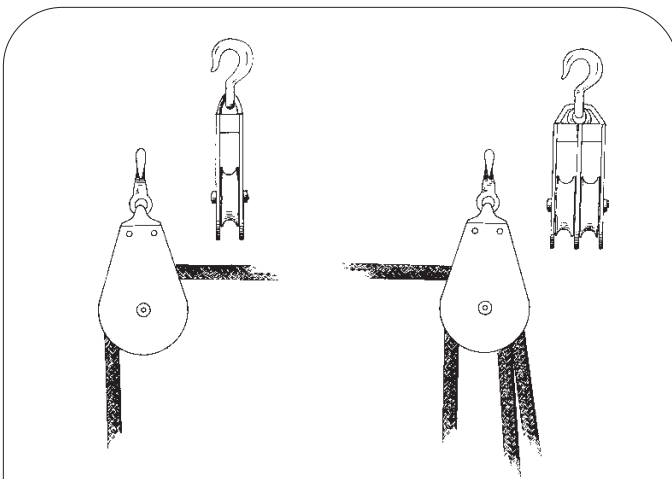

Figure 5.7.3 A combination of a single and a double pulley with a 3/8 inch rope. The rope fits the groove of the pulley wheel.

## Positioning

A pulley is mounted over each side of the trampoline, dry board or platform and wet board. The spotter stands under the double pulley side to operate the ropes. **Gymnastics equipment manufacturers generally recommend that the clamps and pulleys should be positioned so that an approximate 35° angle of the ropes from the waist is achieved** (Milem, 1990). The pulleys should be placed far enough apart to enable the ropes to come down at a wide enough angle to keep the diver from hitting his/her arms on the ropes during the somersaulting dives. **How far apart the pulleys are located depends on how high the ceiling is. The higher the ceiling or mounting area, the further apart the pulleys should be located** (see Table 1). The pulleys are spaced wide enough apart to prevent the chafing of elbows or arms while spinning. The ropes rubbing against the arms and even hips of the diver while spinning can be painful and can actually hinder the diver from performing the skills correctly. Even with the pulleys far apart, the diver will sometimes get rope burns on the arms while being spotted. It is wise to wear a long sleeved sweatshirt to help prevent this from happening.

**Table 1. Angle of rope pull in overhead spotting rigs.**  
(adapted from Milem, *USGF Gymnastics Safety Manual*, 1990)

An approximate 35° angle of the ropes is generally accepted as the ideal angle for providing adequate responsiveness in the spotting assembly while still allowing sufficient clearance without being encumbered by the ropes. This angle recommended by gymnastics manufacturers may be arrived at by employing the following procedure (Milem, 1990).

1. Measure the height from the take-off surface to the ceiling attachment point and then subtract 3.5 feet (approximate waist height).
2. Take the tangent of 35° (.70) and multiply it by the total sum derived in No. 1.
3. Take the product derived in No. 2 and multiply this figure by 2 (for the second attachment point).
4. Take the product derived in No. 3 and add 1.5 feet (approximately horizontal distance across performer's waist).
5. This sum will reveal the horizontal distance needed between two ceiling clamps to achieve the desired 35° angle of pull in the ropes.

For example, if a hypothetical gym has a ceiling height of 25 feet, then the horizontal distance needed between the two ceiling clamps to achieve the desired 35° angle of pull in the ropes would be 31.6 feet.

$$25' - 3.5' = 21.5' \times .70 = 15.05' \times 2 = 30.10' + 1.5' = 31.6'$$

The AAI Installation Instructions for their overhead suspension assembly state that: The width and height measurement will vary to achieve the ideal (35°) angle. However, this angle may have to be sacrificed to somewhat less of an angle due to ceiling height and location. For example, with a ceiling height of 17 feet, the beam clamps and pulleys would have to be approximately 22 feet apart to hold the 35° angle. In some gymnasiums, this would be impractical.

## Pulley Placement

**Trampoline.** On trampoline, the pulleys of the overhead spotting rig are placed over the midline of the trampoline (Figure 5.7.1).

**Dry board/platform.** The placement of the dry board/platform rigs are somewhat different. **Pulleys are placed 2 1/2 to 3 feet in front of the board or platform's leading edge** (Figure 5.7.4). This placement ahead of the end of the take-off surface, enhances the spotter's control. The spotter will then be able to pull the diver away from the board/platform if it becomes necessary for the diver's safety.

**1-meter board over the water.** In an indoor facility the pulleys may be mounted on the ceiling. In an outdoor facility or an indoor facility with a high ceiling, a hinged beam projecting over the spotting station extending from the platform provides a sturdy mount pulley. In general, the spotting rig should be installed 2 and 1/2 to 3 feet forward of the 1-meter board's plummet in the pool in the same manner as over the dry land board.

## Care and maintenance of the spotting rig

It is just as essential to have properly maintained equipment as it is a conscientious, well trained coach to provide appropriate supervision when using the spotting equipment. The ropes should be in good physical condition and travel smoothly in the pulleys. The ropes should be checked for fraying, especially the portion which feeds through the pulleys. Ceiling clamps should be fastened securely to the ceiling anchor points. Pulleys should likewise be secured to the ceiling clamps and operate smoothly. Pulleys should be checked on a regular basis and lubricated often including the pins and the inside of the wheel (see pp. 29-31).

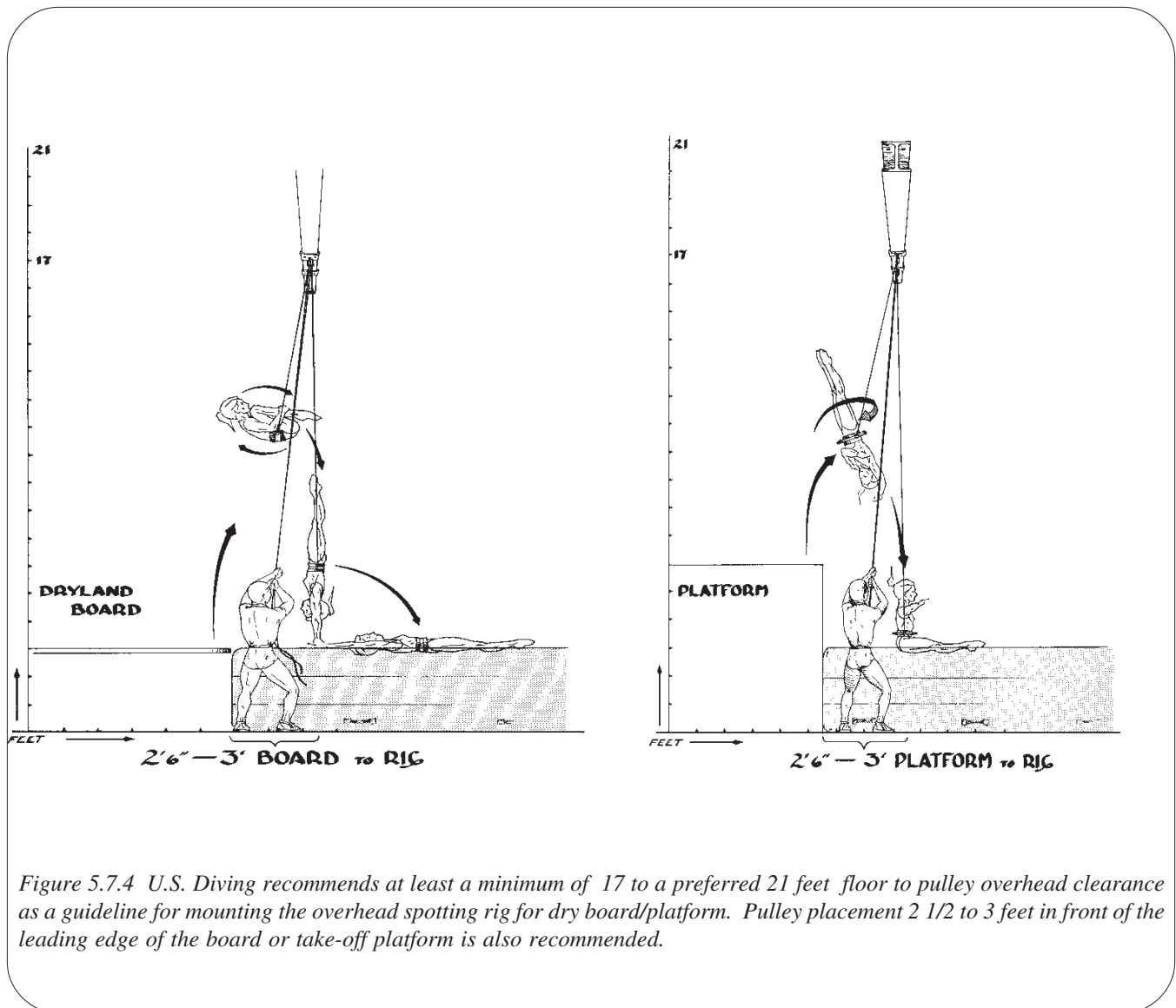

Figure 5.7.4 U.S. Diving recommends at least a minimum of 17 to a preferred 21 feet floor to pulley overhead clearance as a guideline for mounting the overhead spotting rig for dry board/platform. Pulley placement 2 1/2 to 3 feet in front of the leading edge of the board or take-off platform is also recommended.

## Spinal Cord Injury Control Strategies

Although U.S. Diving has no record of a fatality or catastrophic injury related to the use of trampoline, **catastrophic injuries related to the use of the trampoline have occurred on the trampoline bed and are directly related to the improper execution of the somersault. In virtually every accident involving trampolines, one of the primary causes is failure in providing adequate supervision or providing no supervision at all** (Whitlock, 1998).

Trampoline, dry board and dry platform coverage is included in U.S. Diving insurance according to these guidelines:

- ◆ Clubs must be registered
- ◆ All divers must be registered
- ◆ Practice must be supervised by a U.S. Diving coach member
- ◆ Must be a scheduled practice session
- ◆ To minimize the risk of spinal cord injuries, all athletes must use an overhead spotting rig and belt on the trampoline, dry board and dry platform for all dives, twists and/or single or multiple somersaults with two exceptions:

1. On trampoline when no overhead belt spotting is available, a handbelt may be used by two spotters to spot single somersaults on the trampoline (see Figure 5.7.5). This procedure takes a great deal of strength on the part of the spotters and should not be undertaken with a large or heavy diver and is not appropriate for multiple somersaults.

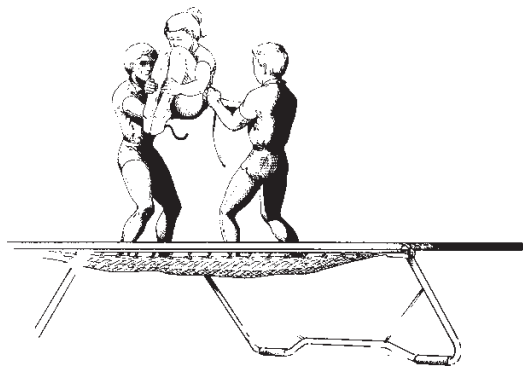

*Figure 5.7.5 Two spotters handbelt spotting single somersault on trampoline*

2. When the diver is not landing on the hands, other spotting methods exist and may be used after the athlete has achieved skill mastery in the belt when appropriate by eligible coaches after completing and passing special training provided by U.S. Diving within the limitations of the Program Aerial Training (PAT).

## Floor Level Spotting

Floor level spotters are placed around the perimeter of the trampoline or dryboard/platform station to provide support when the diver moves in a direction off the trampoline or dry board's portable landing mat or needs an assist to provide stability. Floor level spotters are not necessary in a diving program when the diver is being spotted in a handbelt or overhead belt. **Floor level spotters are not considered to be effective in preventing injuries that occur in the center of the trampoline bed** (Whitlock, 1998).

Once skill mastery with appropriate spotting is demonstrated and with the coach's approval, divers may practice the following skills on trampoline with appropriately stationed floor level spotters as follows:

### Trampoline

- ◆ mount and dismount
- ◆ basic bounce followed by check (stop) bounce
- ◆ controlled bounce with change of direction (twist)
- ◆ jumps (tuck, pike and straight)
- ◆ seat drop
- ◆ hands and knees drop
- ◆ front drop
- ◆ back drop
- ◆ swivel hips
- ◆ step-in hurdle
- ◆ standing back take-off

### Dryboard/platform into portable landing pit

- ◆ mount and dismount
- ◆ standing back take-off with armswing and jump
- ◆ step-in hurdle and jump
- ◆ front approach and jump

## TRAMPOLINE SAFETY GUIDELINES FOR COACHES

**WARN OF INHERENT RISKS**—Know, understand and appreciate the risks involved. **WARNING!** Catastrophic injury, paralysis, or even death can result from landing improperly on the head in an inverted position on and off the trampoline.

**PLAN PROPERLY**—Make sure the emergency action plan is adequate and emergency contact information is readily accessible to the trampoline training station. Lesson plans should take into consideration that overhead belt spotting is a one-on-one activity.

**PROVIDE ADEQUATE SUPERVISION**—The coach's competencies should be commensurate with the tasks. Remember that a lack of adequate supervision is a primary cause of injury in accidents involving the trampoline. To minimize the risk of spinal cord injuries, use the overhead spotting belt on trampoline for all dives, twists and/or single or multiple somersaults.

**PROVIDE A SAFE PHYSICAL ENVIRONMENT**—Verify that the trampoline and overhead spotting rigs comply with U.S. Diving's specifications and recommendations for use. In addition, the area where trampolines are used must be well lit and free of distractions such as excessive noise or flashing lights.

**CHECK EQUIPMENT REGULARLY**—Before use, the trampoline should be checked for defects. Check that equipment is installed and maintained according to the manufacturer's specifications. Any worn, frayed or defective component should be taken out of service. Check that the safety belt is adjusted on the diver to fit properly over the underpad and is buckled securely.

**KNOW THE DIVER'S SKILLS AND LIMITATIONS**—Know the diver's capabilities, skills and limitations and modify the activity accordingly. The best indicator of readiness to perform is a diver's ability to safely perform a basic lead-up skill with similar mechanical requirements.

**PROVIDE PROPER INSTRUCTION**—Teach divers how to bounce in a controlled manner including how to check the bounce in order to stop. Always follow simple to complex progressions. Allow ample time for divers to achieve task mastery at each skill level. Master the basic jumps, drops and landing skills first before somersaulting is attempted in the safety belt.

**PROVIDE PROPER FIRST AID AND EMERGENCY CARE**—Know the procedures and skills necessary to execute the emergency action plan including proper in-line stabilization techniques. Remember that whenever a diver strikes his/her head, it must be assumed that a neck injury is involved.

**MAINTAIN CURRENT COMPETENCIES**—Keep current in U.S. Diving Safety Training for Competitive Diving Coaches as well as first aid and CPR. Maintain physical fitness and spotting proficiency.

**KEEP RECORDS**—Register all clubs, coaches and divers as U.S. Diving members before the diver's first training session.

## TRAMPOLINE USE RULES FOR DIVERS

- ◆ Divers should be dry when using the trampoline.
- ◆ Diving skills on trampoline are practiced as single contact activities, one skill at a time. Initiate take-offs using no bounce, a step-in hurdle, "priming the bed", or several low bounces. High multiple bouncing routines like trampolinists perform are out of the scope of usage in a U.S. Diving program and require compliance with USAG Trampoline and Tumbling Rules.
- ◆ Opening or closing a trampoline can be DANGEROUS. It must be done very slowly and carefully, preferably by more than one person who has experience and procedural knowledge.
- ◆ No diver should use the trampoline unless the activity is being adequately supervised by a qualified coach.
- ◆ Trampolines are to be used for serious diving training, but never for horseplay.
- ◆ Beginning divers can learn many skills with little or no actual bounce on the trampoline.
- ◆ A good jumper is one who can maintain CONTROL while performing skills well, not just "going for the trick".
- ◆ Keep the arms overhead and hands flat to protect the head, neck and spine when simulating head-first entry in the safety belt.
- ◆ Trampolines should be properly mounted and dismounted. Never use a trampoline as a projectile device to jump from or to a trampoline.
- ◆ Only one person should bounce on a trampoline at a time. The only exception is when a coach is physically spotting a skill.
- ◆ Proper attire should be worn when using a trampoline. Avoid clothing that impedes movements, such as street clothes, jeans, etc. Jewelry, including watches, earrings, and rings should not be worn.
- ◆ Never run under a trampoline while someone is on the apparatus.
- ◆ Do not sit or lean with arms on the pads of a trampoline while someone is jumping.
- ◆ Trampolines should never be used by a person who is dizzy, fatigued, or under the influence of drugs, alcohol, or medication which can inhibit coordination or perception.
- ◆ Proper stretching and warm-up can help prevent strains and sprains. It is important that anyone who is going to use a trampoline warm-up properly, both off and on the apparatus, before practice actually begins.
- ◆ Avoid overtraining. Keep turns short; it is difficult for divers to perform well when tired.

## SUMMARY

Diving training stations with spotting rigs for trampoline, dry board, dry platform and wet board enable coaches trained in overhead belt spotting to provide spatial orientation training for competitive divers. Each station has a sport specific application for simulating parts or whole dives in a safety belt with the spotter controlling the ropes. Coaches need to be able to recognize hazards related to the use of this equipment, know the standards related to the installation and use of this equipment, and establish and follow procedures for identifying and correcting unsafe conditions.

## REFERENCES

- ASTM F381-99. Standard Safety Specification for Components, Assembly, Use, and Labeling of Consumer Trampolines. Available from the American Society for Testing and Materials, 100 Barr Harbor Drive, West Conshohocken, PA 19428-2959, TEL: 610/832-9500; Email: [service@astm.org](mailto:service@astm.org); Website: [www.astm.org](http://www.astm.org)
- Clarke KS (1978) Trampoline and diving training statement, accepted by NCAA Diving Rules Committee, March 22, 1978. Endorsed by Big Ten coaches.
- Clarke KS (in progress) 1997 U.S. Diving Injury Surveillance (1993-1996) in Diving-An Overview. U.S. Diving Publications.
- Gabriel JL (1992) Diving Safety, A Position Paper. Indianapolis, IN: U.S. Diving Publications.
- Kimball D (1983) Use of spotting rigs with trampoline, port-a-pit diving board, and regular pool one meter diving board. In Golden D (ed.): Proceedings of the U.S. Diving Sports Science Seminar, Indianapolis: U.S. Diving Publications, pp. 35-47.
- Kimball D (1990) Overhead mounted belt spotting. In Gabriel J, George GS (eds.): U.S. Diving Safety Manual. Indianapolis, IN: U.S. Diving Publications, pp.149-157.
- Milem, DJ (1990) Spotting belts. In George GS (ed.): USGF Gymnastics Safety Manual (2nd ed.). Indianapolis: USGF Publications.
- Mitchell R, Longdon P (1985) Spotting and gymnastic safety. In George GS (ed.): USGF Gymnastics Safety Manual. Indianapolis: USGF Publications.
- 2000-2001 Trampoline Code of Points. USAGymnastics Trampoline and Tumbling Program, USAG Publication.
- Whitlock (1998) Associated activities-trampoline. USA Gymnastics Safety Handbook. Indianapolis, IN: USA Gymnastics Publications, pp. 103-105.

## Part 8. Safety Spotting Belts

by Dick Kimball, M.A.

### SPOTTING BELTS

Spotting belts are buckled securely around the waist of the diver, then attached to ropes that suspend the diver in the air during the airborne phase of the skill, and assist the diver on take-off and landing to enhance safe learning of the basic through the complex diving skills. Ropes are attached to the belt by a clip and handheld by the spotter. The diver is spotted manually, or by feeding the ropes through pulleys in an overhead spotting rig, to give the spotter additional mechanical advantage. There are two types of spotting belts: (1) uniaxial (somersaulting) and (2) biaxial (twisting).

#### Uniaxial spotting belt

The uniaxial belt is used for spotting somersaulting skills around the horizontal axis (see Figure 5.8.1). The uniaxial belt is used for spotting all non-twisting dives. The uniaxial or “basic spotting” belt consists of a safety belt generally made of nylon webbing that encircles the diver’s waist and securely buckles the ends together. This basic safety spotting belt is made with metal rings (anchor loops) sewn into each side of the belt for clipping to the spotting ropes. Pads of varying thickness, depending upon the make of the belt, are usually positioned under the metal coupling rings for protection against friction with the skin over pelvic bones.

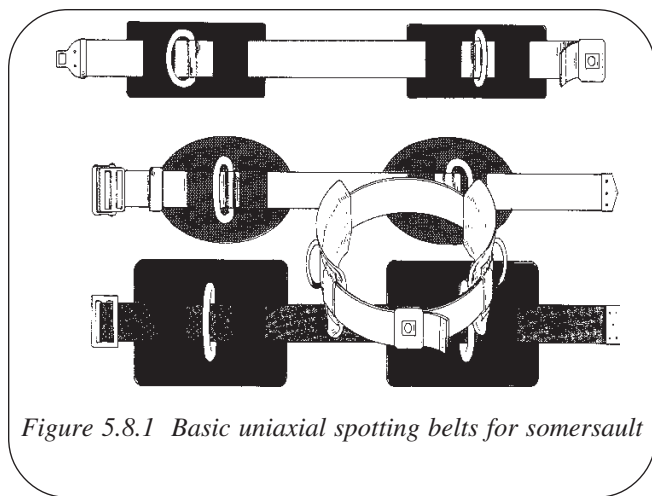

Figure 5.8.1 Basic uniaxial spotting belts for somersault

#### Biaxial spotting belts

The biaxial belt is used for spotting skills with rotation in the somersaulting direction around a horizontal axis and in the twisting direction around the longitudinal axis (see Figure 5.8.2). The biaxial twisting belt is built around the uniaxial

belt. There are several types of twisting belts available, but the most popular twisting belt is the pond belt which has two circles of metal, one inside the other with ball bearings between them. The inside metal circle is connected to a bungy-type shock cord that runs through loops in a uniaxial basic somersault belt which is buckled around the diver’s waist. The twisting belt is more cumbersome and somewhat constrains the full armswing, but is nevertheless a useful tool for teaching jumps with twists and skills involving twisting somersaults.



Figure 5.8.2 Biaxial twisting belt.

#### Swivel clips

The outside metal circle of the spotting belts have metal rings which are situated opposite each other and connect to the clips on the ropes. These clips may be taped closed for added protection. **Swivel clips are recommended as its pivotal axis enhances safety such that the clip remains closed during flight** (see Figure 5.8.3).

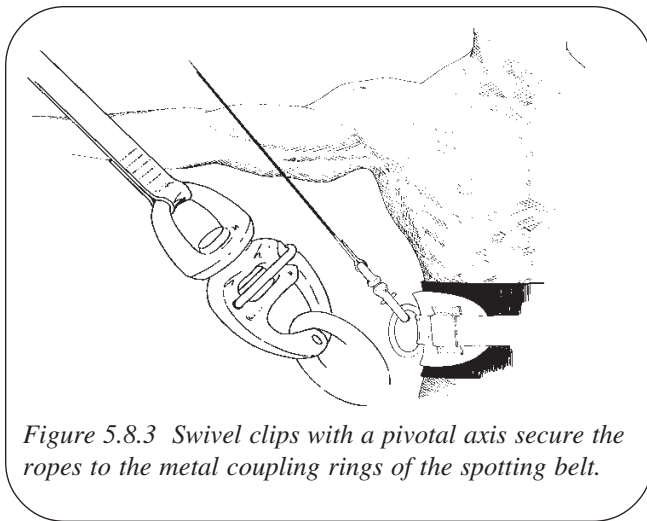

Figure 5.8.3 Swivel clips with a pivotal axis secure the ropes to the metal coupling rings of the spotting belt.

### CARE AND MAINTENANCE OF SPOTTING BELTS

Both types of spotting belts should be inspected continually for fraying and wear around the metal ring attachments. Make sure the belt material is free of wear and that the buckle attachment is working properly. Freedom of movement of the movable parts of the belts is essential to prevent the diver from becoming entangled in the ropes while being spotted. The twisting belt should be lubricated with graphite as often as necessary. Check the shock cord for fraying. The swivel clips should be checked on a daily basis.

### AREAS OF CONCERN

- Children may be started at a very young age, but it is essential that the spotter adjust the belt to fit the young diver snugly. Wide underpads may be homemade out of scuba suit material or thin foam and fitted with velcro to fasten snugly around the waist of divers of all ages. These may be worn under the belts to prevent bruising and pinching of the skin in the overhead mounted belt (see Figure 5.8.4).
- Twisting belts should be worn with the shock cord knobs of the inner belt pointing down.

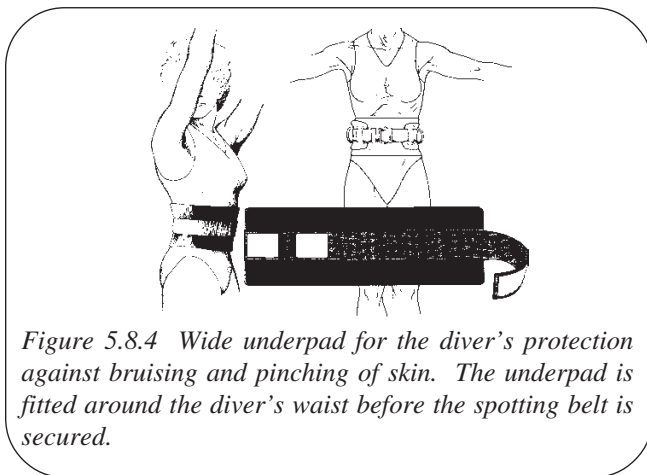

Figure 5.8.4 Wide underpad for the diver's protection against bruising and pinching of skin. The underpad is fitted around the diver's waist before the spotting belt is secured.

### REFERENCES

- George GS (1980) Biomechanics of Women's Gymnastics. Englewood Cliffs, NJ: Prentice-Hall.
- Kimball D (1983) Use of spotting rigs with trampoline, port-a-pit diving board, and regular pool one meter diving board. In Golden D (ed.): Proceedings of the U.S. Diving Sports Science Seminar, Indianapolis, IN: U.S. Diving Publications, pp.35-47.
- Kimball D (1990) Spotting safety. In Gabriel JL, George GS (eds.): U.S. Diving Safety Manual, Indianapolis, IN: U.S. Diving Publications, pp. 141-143.
- Milem DJ (1990) Spotting belts. In George GS (ed.): USGF Gymnastics Safety Manual (2nd ed), Indianapolis, IN: USGF Publications, pp. 47-50.
- Mitchell R, Longdon P (1990) Spotting and gymnastics safety. In George GS (ed.): USGF Gymnastics Safety Manual (2nd ed), Indianapolis, IN: USGF Publications, pp. 57-61.
- Whitlock S (1998) Gymnastics safety equipment. In USA Gymnastics Safety Handbook, Indianapolis, IN: USA Gymnastics Publications, pp. 34-35.



## **CHAPTER VI SUPERVISORY RESPONSIBILITIES**

by Janet L. Gabriel, M.A.

### **CHAPTER COMPETENCIES**

**Upon completion of this chapter, coaches should be able to:**

- Provide proper general and specific supervision of divers.*
- Know the legal responsibilities of the diving coach with respect to supervision and how to meet them.*
- Match participants in terms of such characteristics as age, maturity, size, skill and experience; group participants appropriately.*
- Modify or stop practice or competition when unsafe conditions exist.*

The diving coach has a legal duty to provide adequate supervision of the divers in his/her care. A diving coach is in charge of his/her divers and assistant coaches as they perform diving-related activities. Responsibility for the safety of the diver does not begin and end with the lesson or training session or competition. **Supervision with respect to the diving coach means that the diving coach is in charge of his/her divers from the time they enter the facility until supervision of the diver is assumed again by the parents or guardians.**

Diving coaches have a duty to supervise appropriately. They should be able to administer first aid and CPR and activate the emergency medical system. If appropriate medical assistance is not immediately available, coaches have a duty to provide immediate and temporary care. For every coach that duty includes both specific and general supervisory responsibilities depending on the situation.

## APPROPRIATE SUPERVISION

**Specific supervision** is being at the exact location with the diver such as when handspotting a take-off, calling a diver out of a new dive or giving feedback on a dive. Specific supervision is instructional in nature and directed toward the actual teaching or coaching of the dive or skill. **General supervision** of the locker room means appropriate monitoring. General supervision on the pool deck and dryland training area means placement in a **direct line of sight and close enough to be able to intervene** if necessary or respond quickly in the case of emergency. A diving coach on the deck or in the dryland area is primarily engaged in spotting, observing and/or critiquing one diver's dive and at the same time usually has general supervisory responsibilities for the other divers in the lesson or workout (see Table 1).

Whether the coach uses specific or general supervision depends on the situation. It is the responsibility of the coach to employ the appropriate method. In one situation the coach may decide to handspot a diver one-on-one on poolside or the springboard to learn a new dive. Once the dive is mastered, the diver may perform the dive in recreational swim under the general supervision provided by a lifeguard.

## SUPERVISION RELATED TO RISK

A degree of difficulty (DD) may be calculated for any dive. To determine the DD the formula takes into consideration the following variables: the number of somersaults, flight position, number of twists, direction of approach and unnatural entry. Although degree of difficulty provides an absolute expression of difficulty related to determining a diver's point total, it provides only a relative expression with respect to risk. For example, it is not unusual for the same diver who easily performs even the most difficult dives in the front and inward groups to be at greater risk for hitting the board or landing improperly on high DD dives in the back and reverse groups, or vice versa. Risk on any given dive is dependent on other conditions besides the degree of difficulty. Visual spotting ability, the location of a diver's center of gravity with

respect to height and segment length, technical errors and fear associated with the dive are also considerations. **The rule of thumb is that the more risk associated with a dive by a given diver, the more specific the supervision required, especially when learning a new dive or when the diver's skill mastery breaks down.**

Learning is not linear. Divers may backtrack before they improve. However, at some point in preparation for competition divers have to stop relying on the coach's verbal cue to get out of the dive and take responsibility for the come out. To prepare for competition, divers need to take charge of putting a list of dives together without the coach's direct assistance. When that time comes, the coach may have to switch out of the specific supervision mode and move more into the general supervision mode to signal to the diver that the coach trusts in the diver's ability to perform solo. Physical conditions such as competing at an unfamiliar facility with unaccustomed contrasts in the color between the ceiling and water, or windows that project a glare on the water at the point where the diver is used to seeing his/her spot can increase the risk of landing incorrectly. As the risk increases the coach may need to switch gears from general supervisory feedback, such as telling the diver he was on or over on the entry, to specific supervision, such as putting the diver back in the spotting belt. Appropriate supervision means that diving coaches should be flexible and adjust to the demands of the situation.

## SHARED RESPONSIBILITIES

In pools the general supervisory duties of lifeguards to the facility users overlap with the diving coach's duties to his/her divers. In many situations, the coach's supervisory responsibilities may be more complex than the lifeguard's. In many situations this complexity may be offset by the fact that a lifeguard may be monitoring ten times more pool users than a diving coach. In many aquatic emergencies, response time is critical. For that reason, safeguarding the diver is the shared responsibility of the coach, the lifeguards, the pool manager and other divers.

Pool managers/licensees are required to comply with their state, county and in some cases their city codes. Pool managers/licensees should have written policies and procedures related to emergency response situations in their facility. The discriminating emergency plan bridges the gap between compliance and effectiveness. In the event of a potentially catastrophic competitive diving accident, such as might occur when a diver hits his/her head on a platform or springboard or when a diver is conscious or unconscious when submerged, response time is critical. While a lifeguard may be the first to respond to an emergency, coaches, assistant coaches and divers should have responsibilities in the event of a diving rescue emergency (ARC (1996), p 20.). All designated professional staff trained in emergency procedures should go to the diving area to provide assistance as established in the emergency plan. Spinal injury management in deep water requires a minimum of two persons. If only one lifeguard is on duty at the pool, the diving coach trained in

**Table 1. Examples of General and Specific Supervision for Diving Coaches**  
**These examples may include but are not limited to the following:**

QUESTIONS	DIVING COACH-GENERAL	DIVING COACH-SPECIFIC
<b>Who can be a supervisor?</b>	-Conditions of hire are set by the employer according to the state, county and/or city regulating agency. U.S. Diving coach membership requires the coach to be current in first aid, CPR and U.S. Diving Safety Training for Competitive Diving coaches	-Coaches attending competition and training centers under the USOC governance must be current in ARC/USOC Sport Safety Training
<b>What is the scope of the supervisor's duties?</b>	-Enforce the pool and club rules -Know and practice the proper emergency procedures	-Identify talented athletes -Teach new dives -Ready competitive divers to perform
<b>What does instruction involve?</b>	-Unlock and lock diving pool entrance -Monitor locker room use -Check condition of diving boards -Check on access to spineboards, straps and cervical collar(s)	-Conduct Dive Safe lessons -Develop a periodized training plan -Conduct junior and senior divers' training sessions
<b>How many supervisors are needed?</b>	-Manageable coach to diver ratios depend on the blend of specific and general supervisory demands	-Maximum of one Dive Safe coach per ten learn-to-dive participants
<b>Where should the supervisor be located?</b>	-Be stationed in a direct line of sight to the divers and close enough to be able to intervene or respond to an emergency	-Depends on the demands of the skill and the readiness of the diver
<b>What should the supervisor look for?</b>	-Assess the diver's swimming skills either by a swimming test or placement criteria or both -Assign divers to diving boards and platforms and supervise the training or competition session	-Assess the diver's performer readiness related to skill progressions and fatigue -Provide appropriate feedback related to preparation and performance of dives and skills with respect to take-off, flight and entry
<b>What should the supervisor listen for?</b>	-Sound of a diver hitting the springboard or landing flat on the entry.	-Sound that the diver makes when he/she catches the board on the way down in its oscillation or stomps the board on its way up
<b>How should the supervisor identify potentially dangerous activities?</b>	-Warn the diver of the inherent risks involved in the sport of diving before the diver participates	-Inspect the facility and equipment -Modify the activity if needed -Check for adequate room to maneuver, dive height and safe clearance on every dive
<b>How can the supervisor understand the warning signs of impending trouble during an activity?</b>	-The diver will not be able to make a distance correction on the next attempt	-The diver is unable to maintain balance
<b>What is a stop signal that can be used when the supervisor must immediately suspend activity?</b>	-Blow a whistle or use body language i.e. make the "Timeout" hand signal followed by the "You're out" signal	-Yell "Stop"

deep water spinal injury management may assist from the deck or the water. Rehearse these procedures regularly. Repetition develops confidence and the likelihood that procedures will be conducted competently. Coaches must remember that in all cases their main responsibility is the safety of their divers.

### **WHO CAN BE A SUPERVISOR?**

The appropriate state regulating agency determines whether or not a lifeguard is required at a pool. If required, the number of lifeguards posted generally depends on the size of the pool and/or the number of pool users. For example, in some instances diving pools may not be large enough for a lifeguard to be required. In others, only one lifeguard is required to be posted if the pool has a limited number of users. Some states allow coaches to act as lifeguards during practice and/or meets provided the coaches have first aid, CPR and rescue training. Some state codes also address requirements for the training of lifeguards and coaches/instructors.

CPR cannot be performed in the water; it can only be given on the deck. Injured divers with suspected spinal cord injuries should be backboarded in the water. Paramedics do not generally arrive dressed in swimming suits. Backboarding in the deep water requires a minimum of two people. A diving coach trained in deep water rescue related to competitive diving injuries and spinal injury management may assist with the emergency action plan.

Being a supervisor in the aquatic environment requires special skills. Lifeguard training provides lifeguards with the training appropriate to their general supervisory responsibilities. The courts have found coaches liable for their failure to know how to move athletes with suspected neck or back injuries. In addition to specific supervisory skills related to teaching dives and coaching, diving coaches should know how to perform basic first aid, CPR and other emergency procedures (activate the emergency system, rescue and spinal injury management) regardless of whether athletic trainers or lifeguards are available.

### **MATCH TASK DIFFICULTY WITH RESPONDER READINESS**

To prevent drowning in an aquatic environment, response time is critical. In some situations the coach may be the first responder. Appropriate qualifications are not the only important factors to consider with respect to the emergency action plan. In addition to being qualified, other interwoven factors should be taken into consideration in order to appropriately match the task difficulty with the rescuer readiness. These factors include: the number, size, age, experience and skill of the diver with respect to the requirements of the rescue and injury management skills; the skill, size and availability of the qualified supervisors; and the equipment available. For example, is the rescuer able to dive to the bottom of the deep diving well on a given day? Sinus infections and/or ear pressure problems may vary for individuals on a daily basis. How does the size and skill of the rescuer relate to the size of the diver? Without fins to augment one's ability to kick, a

small lifeguard or diving coach may not be able to overcome the difference in weight needed to bring a much larger diver up from the bottom of a deep diving well.

### **GENERAL SUPERVISORY STRATEGIES USED BY DIVING COACHES**

There are five strategies that may enhance a diving coach's general supervisory skill in some situations. These strategies include:

#### **Elevated coaching stations**

Being stationed in an elevated position such as a lifeguard chair enables a more direct line of sight to the bottom of the pool and reduces the likelihood of being interrupted and engaged in conversation by a passerby. Such a perch may provide a good vantage point for coaching a platform workout but might be counterproductive for teaching young children in a learn-to-dive lesson, or it may inhibit a given coaching style.

#### **Voice amplification**

Pool noise levels vary. In situations where the coach's voice does not carry over the noise, a bull horn or microphone might help, especially when controlling traffic off the platforms.

#### **Manageable coach to diver ratios**

One lifeguard may be guarding 75 pool users depending on state codes. How many divers one coach can handle effectively in a workout depends upon the blend of specific and general supervisory demands related to the number of diving boards or platform levels available, the distribution of the divers on the boards, the skill and age of the divers, the supervisory skill and experience of the coach, the difficulty of the skills performed and the emphasis of the workout.

Lifeguards generally find themselves guarding a diverse population varying in age and swimming and diving skills (American Red Cross, 1995; On the Guard, 1994). Lifeguards are charged with the duty of guarding swimmers and non-swimmers. The typical pool user considered a swimmer in a recreational sense does not generally possess the swimming and diving skill of the typical competitive diver.

Diving coaches, on the other hand, only have a duty to supervise their divers. Even in a diving lesson, nonswimmers are screened out of diving classes either by placement criteria or by a swimming test, or both. In addition, coaches generally place divers of similar skill and ages together in a training session or lesson. The U.S. Diving Dive Safe learn-to-dive program has three skill levels: Bronze, Silver and Gold. In addition, U.S. Diving Dive Safe coaches strive for a maximum 1:10 coach to diver ratio. In most cases, the diving coach's supervisory task difficulty when coaching a small group of competitive divers is less onerous than that of a lifeguard who has a large heterogeneous group to oversee.

## **Proximity of coaching station related to emergency response time**

A child may struggle at the surface for as little as 20 seconds before submerging (ARC, 1995). Lifeguards strive to achieve the 10 x 10 reaction (i.e. 10 seconds to scan x 10 seconds to respond; YMCA, 1992). A diving coach with general supervisory responsibilities that include rescue should, locate his/her coaching station within 20 seconds reaction time to the farthest diver. In most coaching situations proximity is a given because the coach may talk to the diver between almost every dive. This placement increases the likelihood that the diving coach is in position to be the first responder in the event of a competitive diving injury requiring emergency response.

## **Traffic control protocol skill mastery**

The diving coach teaches divers ground rules for workouts and competitions that relate to safe and effective use of the pool. Mastery of traffic control protocol by both the coach and divers in a workout reduces the general supervisory task. A lifeguard needs to scan the area continually because recreational use of the pool is less structured and therefore less predictable than competitive uses. In most recreational situations the facility opens designated springboards and sometimes platforms to the public. Within pool rules, a pool user chooses where and when to swim or dive and may randomly change from the shallow end of the swimming pool to the deep diving well. In many competitive diving workouts, mastery of traffic control procedures enables the coach to know and follow the sequence of divers and dives. Inherent in this traffic control protocol is a built-in head count which may in some situations mitigate the need to scan.

## **TRAFFIC CONTROL PROTOCOL**

Embedded in the competitive diving traffic control protocol are many layers of checks and balances that facilitate the general supervisory responsibilities for the coach.

**Sequence.** In many diving workouts, depending on the skill emphasis, a sequence of divers may be established either by the coach or by the divers or by both. The pecking order may change from workout to workout. Divers generally follow the same diver throughout a workout so that everyone gets his/her turn and the coach sees the majority of the dives.

The protocol is for the competitive diver to wait his/her turn until the coach is finished providing feedback and instruction to the preceding diver in the order. A diver is generally motivated to dive when the coach is ready and watching because if the coach misses seeing his/her dive, the diver may have to repeat the dive in order for the coach to: 1) verify that the diver has made the correction requested; and/or 2) to determine the diver's performer readiness to advance in the progression. When ready to go, a diver if necessary may call to the coach to get his/her attention and will usually wait to go until the coach is ready to watch.

## **Clearance awareness**

From early on competitive divers are taught in training sessions to check before every dive to verify that the entry area is clear before initiating the take-off. Inherent in the activity, many divers develop a mature directional awareness. If a diver or teammate jumps to the side of the board on a dive or even twists slightly on an entry, it will probably be noticed by one set of watchful eyes. Such an error might mean a deduction in competition by a judge. If the diver on the next board jumps to the side, a diver with clearance awareness mastery will wait to see where the diver surfaces before taking off.

## **Distance Awareness**

Divers may be taught to look for their entry bubbles and to surface in the same "hole" that they entered. This procedure enables the diver and coach to verify the diver's distance on every dive. Competitive divers are generally motivated to monitor distance because being too far away from or too close to the board may result in a deduction in the judges' scores.

## **Take-off initiation criteria**

The next diver in the workout order may be signaled to go by the coach. For example, on tower the coach or an appointed traffic controller calls out the level of platform cleared for take-off. In an orderly workout sequence on springboard a diver may know to go by default without a signal. If all the criteria for clearance are fulfilled (i.e. the preceding diver has cleared the area and the coach is watching), the diver automatically knows to go next.

## **Temporal awareness**

Just as in competition where the announcer aims to announce the dives on a prescribed interval, a workout rhythm develops in a training session with a set sequence. A coach and his/her divers are likely to sense when the rhythm is disrupted, such as when someone drops out of the round. The coach and divers are likely to notice the deviation because it requires them to alter their behavior and to be ready sooner than before.

## **Checks and Balances**

Competitive diving's layered traffic control protocol is replete with checks and balances. Sequence protocol enables group synergy so that more than one set of eyes follow the workout. The divers waiting their turns on the various boards are often watching their teammates' dives as well. If the coach "misses" seeing a dive, the other divers in the workout may verify for the coach that the diver has made the specified correction, or report to the coach if a teammate is too close to the board. This check increases the likelihood that the diver will make a distance correction on the next trial and thus reduces the risk of injury from hitting the take-off surface.

Hitting the springboard or landing flat in the water have unmistakable sounds associated with the potentially injurious event. Even if the coach misses seeing the diver hit the board or crash the entry, the sound would tip the coach off to check on the diver.

In a workout with a group schooled in traffic control procedures, general supervision is nearly automatic. Both the coach and his/her divers are likely to notice if a teammate ahead of a particular diver in the workout does not surface. The coach would notice because he/she is waiting to give feedback to the diver before the next diver goes. The next divers in the order would notice if a teammate doesn't surface because he/she is constantly monitoring his/her own readiness to go on cue with respect to clearance in the entry area and glide path so as not to hold up the workout.

## **APPROPRIATE BLEND OF SPECIFIC AND GENERAL SUPERVISION**

The appropriateness of each of the five factors and corresponding subsets depends on the situation. In certain contexts a given factor may not be applicable or practical at all. Each situation has its unique challenges. Noise levels vary as do facility configurations. Some equipment is lined up at one end of the pool and in other situations equipment is located at both ends or at right angles. Sometimes the diver will have to go to the opposite end of the diving well to do a lead-up at a particular station. In some facilities 1-meter and 3-meter boards are clustered together. A coach's size may compare favorably with a young child's size but unfavorably with an adult-sized diver who might also weigh more. Some coaches train competitive divers during recreational swim, others share the diving well with swimmers and swim lanes. Still other coaches have quiet pool time solely dedicated to diving. Since lifeguards are often recruited from swimming and diving teams, some diving coaches even coach divers who are themselves employed as lifeguards.

Pool managers/licensees and coaches need to be aware of the factors that effect the supervisory task and thus the locus of control in the diving well and they need to be flexible enough to find parity. These factors should work in concert to achieve the appropriate blend of specific and general supervision. All factors do not need to be present simultaneously for supervision to be appropriate. Supervision is a learned skill and its effectiveness depends not only on physical conditions but also on the skill mastery of the coaches and divers involved.

In situations where supervisory skill is developed only to the awareness level, the more compelling is the need to have a lifeguard present to strike an acceptable balance. As the indicators of supervisory effectiveness are coordinated and supervision skill mastery is achieved, the more self-sufficient is the coaching situation.

## **AREAS OF CONCERN**

### **RESTRICTING UNAUTHORIZED ACCESS**

Depending on a given coach's job responsibilities, he/she has responsibilities related to restricting unauthorized access to equipment, entrances and exits.

## **Equipment**

Some facilities have trampolines and dryland equipment on the deck. Coaches need to know who is in charge of such equipment and when and how it should be secured to restrict unauthorized access. Coaches should know how to restrict unauthorized access to diving platforms when the pool is closed or unsupervised. In the case of stacked platforms there should be a means to block the use of one of the platforms when either the platform above or below is open for use.

## **Entrances and Exits**

Coaches should also be aware of whose responsibility it is to secure locker rooms, dryland training areas, resistance training areas, classrooms, offices, and direct entries from the street to the aquatics facility. Coaches must also know the emergency medical service point of access to the deck in case of emergency.

## **PRACTICE IN NONCONFORMING POOLS**

U.S. Diving recommends that all practice sessions be held in pools that comply with the minimum depth and other dimensions set forth in the U.S. Diving Rules and Regulations.

If any pool is used for practice that does not meet these dimensions, all divers and coaches using the pool for the first time should be advised of the nonconforming dimensions of the practice pool, particularly those affecting room to maneuver underwater (see H (water depth at plummet), A (from plummet back to pool wall), J-K (distance and depth ahead of plummet) and L-M (distance and depth each side of plummet)). It follows that if the diver feels he/she is not able to maneuver in any depth, be it 9 or 12 feet, the decision should be made in that situation not to dive; or if the decision is to dive, that it be made voluntarily with appreciation and assumption of the potential risk of serious injury, paralysis or death.

Divers who regularly train in nonconforming pools are usually well aware of their pool's limitations and govern themselves accordingly. Divers and coaches who are new to any nonconforming practice pool must be particularly warned about the pool limitations; in fact, all divers and coaches are urged to fully familiarize themselves with the actual dimensions of any new pool before making head-first entries. Enter the deep water in the diving area feet-first the first time in an unfamiliar diving facility.

## **RISK OF COLLISION**

### **Shared Use of the Diving Well**

Shared use of the diving well may be appropriate depending on the circumstances, provided the space is available and the traffic flow of concurrent activities does not compromise the safety of the facility users, especially with respect to the risk of collision.

## Stacked Platforms

In a stacked platform design, divers standing on the platform above are unable to see if another diver on the platform below is diving, and vice versa. **Stacked platforms require a traffic controller verbally to “call” which platform is cleared for take-off. Due to the increased risk of collision with another diver inherent in a stacked platform design, it is essential that the divers are able to hear the traffic controller over the noise of the pool environment.**

## Collision in Glide paths

**When diving equipment is placed at right angles or at opposite ends of the pool, there may be an increased risk of collision. Coaches may need to stagger take-offs from equipment at right angles or opposite ends.** Springboards at opposite ends of the pool may be offset to minimize the risk of collision above water and in the divers’ underwater glide paths.

## TEACHING HEAD-FIRST DIVES FROM THE DECK IN NONCONFORMING POOLS

The long shallow dive is used for entering the water head-first at a shallow angle with great forward momentum. The Red Cross (1992) recommends that the long shallow dive, should only be done *“in clear water of known depth. Do not try to learn this dive in less than 9 feet of water. Never do it thereafter in water shallower than 5 feet”*.

## FEAR MANAGEMENT

Coaches and divers have to contend with the elements of fear (fear of heights, of becoming disoriented in a dive, of improper landings on the water, of hitting the board or platform) inherent in diving. Due to the nature of the risks and fears involved, it is the coach, not the diver, who ultimately must have the final decision regarding performer readiness to dive. Coaches should not force, intimidate or coerce a diver into attempting a new skill or dive. Coaches should respond appropriately when a diver expresses doubts about trying a new skill or dive. Divers should voluntarily assume the risk of performing.

## SPINEBOARD

Not all state regulating agencies require a spineboard. Programs with competitive diving should have at least two spineboards available along with the appropriate straps and cervical collar(s). In the event that one spineboard is sent to the hospital with an injured diver, another spineboard needs to be available to continue the practice or competition.

## NO DIVING IN SHALLOW WATER

Careless diving water entry into shallow water (5 feet deep or less) is an extremely dangerous activity. The risk of injury from the head’s impact with the bottom increases as the child matures into an adult-sized body with increased height and weight. Facility users need to appreciate this increased risk and adjust their behavior accordingly.

## ALCOHOL

Approximately half of the shallow water entry spinal cord injury victims consumed alcoholic beverages prior to sustaining the injury (Gabrielsen & Spivey, 1990). These statistics clearly show that **DRINKING AND DIVING DO NOT MIX!** (Egstrom & Rowley, 1986).

## SPRINGBOARD LADDERS

Children who do not yet demonstrate mature climbing movement patterns should not climb the 3-meter springboard ladder unassisted. Children using a 3-meter ship ladder may find it more suitable to climb the ladder using a hand-over-hand pattern so that the diver is always holding on with at least one hand. A young diver may need to grab the rungs if the rails or hand grips are too wide for his/her arm span or if the support posts have too great a circumference for the child to grab. Divers who climb down the ladder should climb down facing the ladder using a hand-over-hand pattern (Gabriel, George, Kimball, O'Brien & Xie (1995; see Figure 6.1).

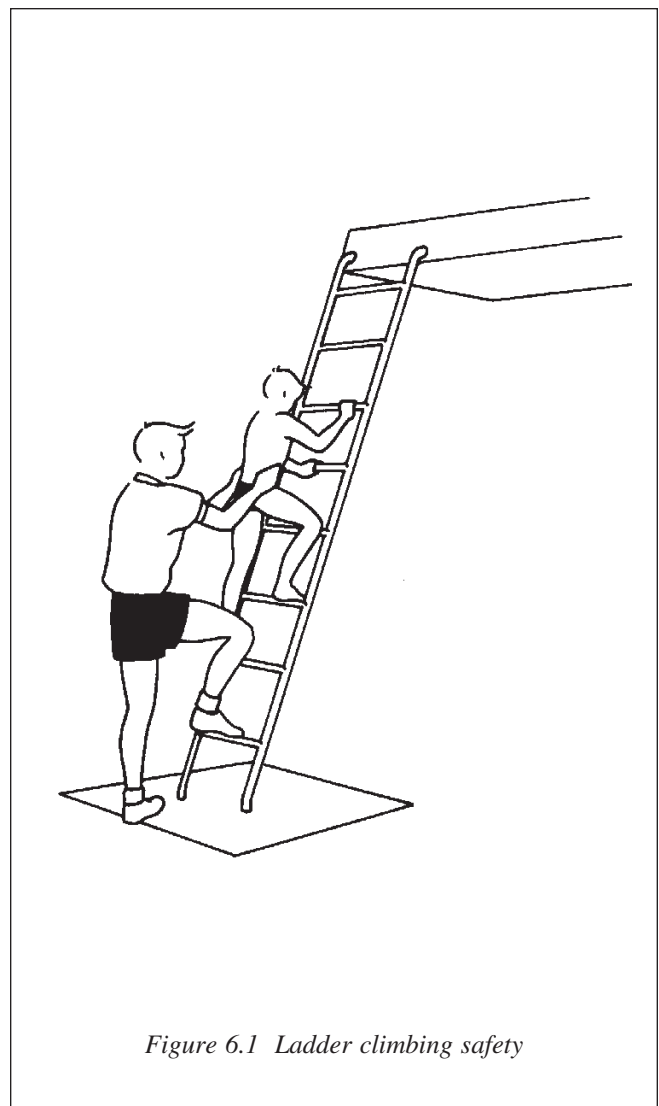
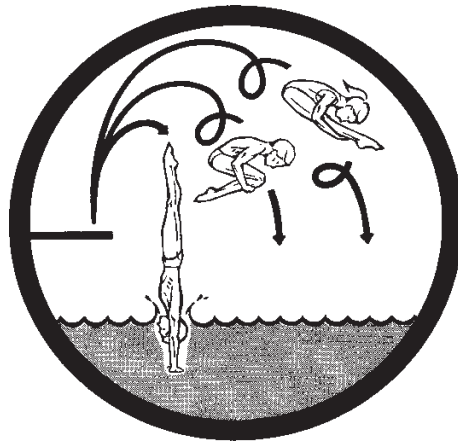

Figure 6.1 Ladder climbing safety

## REFERENCES

- American Red Cross (1992) *Swimming and Diving*. St. Louis, MO: Mosby Year Book. pp. 88, 104.
- American Red Cross (1995) *Lifeguarding Today*. St. Louis, MO: Mosby Lifeline, pp. 53-69.
- American Red Cross (1996) *Safety Training for Swim Coaches*. St. Louis, MO: Mosby Lifeline, pp. 7, 20.
- Egstrom, GH, Rowley WN, Wilson RR (1986) Alcohol and diving performance. University of California, Los Angeles, Department of Kinesiology, p. 49.
- Gabriel JL (1992) *Diving Safety, A Position Paper*. U.S. Diving, Inc. pp. 1-3.
- Gabriel JL, George GS, Kimball D, O'Brien R, Xie C (1995) *Dive Safe*. Indianapolis, IN: U.S. Diving Publications, p. 16.
- Gabrielsen M, Spivey M (1990) *Diving Injuries: The Etiology of 486 Case Studies with Recommendations for Needed Action*. Fort Lauderdale, FL: Nova University Press, p. 4-7.
- Louganis, G. (1990) Landing and entry. In Gabriel JL, George GS (eds.): *U.S. Diving Safety Manual*. Indianapolis, IN: U.S. Diving Publications. p.110.
- On the Guard II: *The YMCA Lifeguard Manual* (1994) Champaign, IL: Human Kinetics (2nd Edition), pp. 29-30, 37, 72.
- Sawyer T. (1992) Legal issues in coaching. In Seefeldt V, Brown EW (eds.): *Program for Athletic Coaches' Education Reference Manual*. Dubuque, IA: Brown & Benchmark, pp. 25-4 - 25-5.



## CHAPTER VII PROPER INSTRUCTION

### CHAPTER COMPETENCIES

**Upon completion of this chapter, coaches should be able to:**

- *Know and apply steps for systematically instructing divers as they progress developmentally in diving skills.*
- *Identify the desirable characteristics and abilities to be attained by each diver throughout the season and consider these when preparing regular evaluations.*
- *Provide divers with evaluations of personal achievement and discuss the results with each diver individually at regular intervals.*
- *Teach skills and strategies that are within performance limits of the diver.*
- *Know the specific risks to participants and how to reduce these risks in diving.*
- *Know which training/conditioning activities are potentially harmful (contraindicated) for divers; avoid using these activities in coaching diving.*
- *Know how skill instruction and coaching decisions influence the risk of injury to divers.*
- *Assess divers' success in learning skills relative to their physical limits.*
- *Know the legal responsibilities of the coach in teaching and how to meet them.*
- *Match spotters to divers in terms of such characteristics as age, maturity, size, skill and experience; group spotters and divers appropriately.*

# Part 1. Using Skill Progressions in Diving

by Ron O'Brien, Ph.D.

## USING SKILL PROGRESSIONS

Knowing what to teach and how to teach correctly is of the utmost importance to diving safety. However, knowing when to teach the skills and in what order is equally important. This is known as skill progression. Only when a coach has a thorough grasp of all these areas will safe and effective instruction take place.

Skill progression is a game plan or blueprint to be followed, but also altered when necessary to meet the individual needs of each diver. Skill progression begins with the very first skill taught and continues to the end of the diver's career. **The diver should always be in the process of progressing, no matter what the level of skill.** When parts of the dives are no longer practiced in isolation and when the repetitive use of skill progression patterns is not utilized, improvement is significantly reduced.

## GOALS AND PROGRESS

A well thought out and developed skill progression plan can result in some very important basic goals being achieved, namely:

1. safe and logical transition from one skill to another
2. effective teaching of sound fundamentals
3. providing the diver with the best opportunity to reach full potential

As important as having the proper skill progression program is its monitoring and control by the coach (see the Dive/skill quality assessment form on page 34). Patience must be the key factor in allowing each skill to be thoroughly learned, through consistent repetition, before moving on to the next level. If this is not the case, safety is compromised and a breakdown in the progression chain most likely will occur somewhere at the more complex skill level, prohibiting the diver from advancing further or from performing the complex skill required in a proficient manner. **Additionally, each diver must be allowed to advance at a pace consistent with his/her ability to enhance safety and to promote the proper execution of the movements desired.**

## SIMPLE TO COMPLEX

The basis for learning is a **simple to complex progression**. Imbedded in this progression are three levels of skills: core skills, lead-up skills and complex skills (see Figure 7.1.1). Some skills may be interchangeable in progressions when there are similarities in the dive groups. For example,

skill mastery of a leg-first kick on the back line-up tuck and the back dive tuck has application throughout the back progression for multiple somersaults with head-first entries, as well as throughout the reverse simple to complex skill progression.

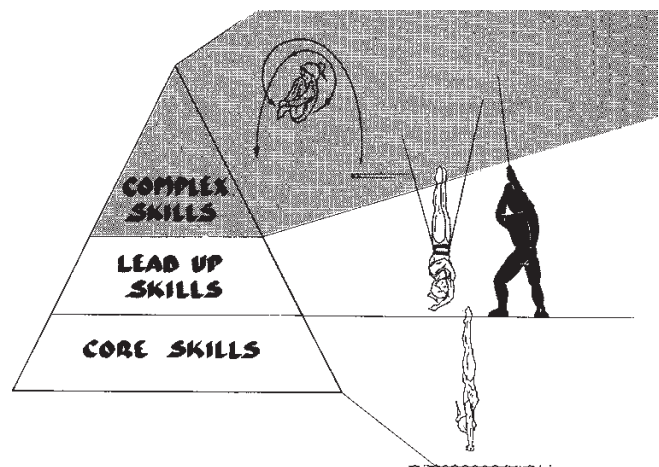

Figure 7.1.1 Simple to complex skill hierarchy

## Core skills

Core skills include a broad spectrum of skills which develop the basic fundamentals necessary for safety and success later. Core skills should be learned first, as they provide a basis for positive transfer of learning. Core skills such as entry, squats, armswing, body alignment, comeouts, toe point, basic dives and single somersaults in all four dive groups and forward 1 and 1/2 somersaults have a broad application in all groups.

For the beginning diver and in many instances even for the intermediate and advanced diver, some of these diving skills can be used in a competitive list of dives. In order to emphasize correct and complete mastery of these core skills by the beginning and intermediate divers, it is urged that a skill testing program be used by the coach to evaluate proficiency on the skills as they are learned.

## Lead-Up Skills

Intermediate level skills may also be used as competitive dives as well as preparation for the more complex dives to be executed later. These skills include up to 2.5 somersaults in all four non-twisting dive groups, 1.5 somersaults with 2 twists forward and 1.5 twists in the back and reverse groups. These dives should be learned from the 1- and/or 3-meter

springboards where appropriate as well as from the 1-, 3-, 5- and 7.5-meter platforms as dictated by the age group rules, safety and effective transition to more complex skills. The use of the trampoline and dryland diving board, dry platform, and wet board and wet platforms with overhead spotting rigs is also encouraged where possible to teach these skills safely and efficiently.

### **Complex Skills**

Complex skills are advanced dives used in high level competition and based on the fundamentals learned in the core and lead-up categories. These skills can be practiced from 1- and 3-meter springboards and 1- through 10-meter platforms as appropriate. Complex skills in general include up to forward 4.5 somersaults, back, reverse and inward 3.5 somersaults, and twisting dives with 3.5/4.5 twists. Some of these skills are lead-ups which cross over into the complex skill classification because of their high degree of difficulty. The use of overhead spotting rigs provides opportunity for skill repetition and mastery.

It is the responsibility of the coach and diver to make prudent decisions and exercise good judgment as to what skills will be taught at what height. Safety, logical transition of the skill and the diver's ability to perform the movements are the key determinants. For example, inward double and triple somersault lead-ups are extremely difficult to execute with good control and a safe landing. A forward somersault with 1 twist, or a forward double somersault tuck position from the 5-meter platform are also extremely difficult to control on landing.

### **DEVELOPING A SPECIFIC SKILL PROGRESSION**

Specific skill progression entails drawing on isolated parts of the core, lead-up and complex skill categories, as needed, to develop a training plan which allows the diver to perform a predetermined dive safely and effectively. To do this, a five step process should be followed:

1. **Observe** the skill to be accomplished by watching video tape, film or actual dives done by someone who executes the dive properly. The coach and diver need to have a good visual image of the desired final result.
2. **Analyze** the various component parts of the skill movements to determine what has to be taught and in what order. By breaking down and understanding the individual skills needed to perform the whole skill complex the teaching and learning task will be more focused and not so overwhelming in scope.
3. **Isolate** the parts of the dive to be taught into training drills which are as easy as possible for the diver to perform and allow for a high number of repetitions. At this point in the skill progression, an evaluation of equipment and facilities is necessary by the coach. Since each training situation has

different advantages and disadvantages, this will dictate how the skills can be taught.

4. **Combine** isolated simple training drills into more complex drills which move the diver closer to the overall skill performance. When and how this is done depends on the task mastery that the diver displays in the isolated skill training.
5. **Perform** the desired skill using all the practiced movements from steps 2 and 3. If the component skills have been taught correctly and repeated enough so that strong habit patterns have been developed, the overall skill should be performed effectively.

Prior to performing the total dive, if dry board/platform or wet board/platform spotting rigs are available, spatial orientation training is extremely valuable and productive. By having the diver perform the new dive many times in the safety of the spotting equipment, the feeling of the whole dive can be experienced, thus enhancing the chance of success on the first try.

### **BASIC GUIDELINES FOR SKILL PROGRESSION USAGE**

Guidelines to be followed in developing and implementing skill progressions as well as recommendations for monitoring the diver through the learning process include:

1. Take the time to develop a skill progression plan to follow, not only for learning new dives, but for use in setting up short and long range training programs.
2. With beginning divers, spend more time on physical readiness and dryland skills than on diving skills.
3. As mentioned earlier, be sure sufficient repetition of each skill is performed so that safety and task mastery are served first.
4. Insist on proper execution of lead-up skills before moving on to more complex movement patterns.
5. Be sure both coach and diver understand the movements to be made and the reasons why they are to be made.
6. Proceed from simple to complex skill acquisition.
7. Assess the diver's "readiness" to move on. Does the diver demonstrate:

- Good balance
- Safe distance
- Spatial orientation
- Sufficient strength
- Good form

8. **Don't allow deadlines or pressure from the diver or parents to accelerate the skill progression process. Upcoming competitions many times interfere with progress and sometimes safety by causing skills to be learned too quickly.**

9. Don't be afraid to regress in order to progress. At times it will be necessary to go back and practice various preliminary skills to further develop good movement patterns. By retreating and retracing the skill progression the diver ultimately is more successful.

10. Always continue to practice the most productive lead-up skills.

11. Patience and wise decision-making on when to move to the next skill are paramount in helping the diver develop sound fundamentals necessary for a safe, high-quality performance of the complex diving skills.

## **REFERENCES**

Miller DI, Munro CF (1985) Greg Louganis' springboard takeoff: II. Linear and angular momentum considerations. *International Journal of Sport Biomechanics*. 1: 288-307.

O'Brien R (1992) *Diving for Gold*. Champaign, IL: Leisure Press, pp. 153-176.

O'Brien R (1990) Using skill progressions in diving. In Gabriel JL, George GS (eds.): *U.S. Diving Safety Manual*. Indianapolis, IN: U.S. Diving Publications, pp. 135-139.

## Part 2. Safety Spotting

by Dick Kimball, M.A.

The goal of competitive diving is for the diver to be able to perform all the dives in his/her list unassisted during practice and competition. Like the use of the sparging system or skill progressions, safety spotting is a method to facilitate safe performance of complex skills. **Spotting is defined as the strategic manipulation and observation of a performer through a skill (or series of skills) to its completion to minimize the risk of injury and to facilitate learning** (Mitchell & Longdon, 1985). Manipulation may be done with the hands or belts. When appropriate and as the diver gets more proficient, the coach uses specific supervision, positions him/herself nearby ready to assist with a verbal call if necessary. During competition divers perform a dive list without assistance. General supervision is provided in the pool by the coach and/or lifeguard.

### PURPOSES

The purposes of hand and/or belt spotting of a diver are to:

- avoid having the diver hit the board or land incorrectly
- to exert forces necessary to the proper and safe execution of a skill
- develop confidence
- decrease learning time
- teach new dives, somersaults and twists
- to develop motor programs that enable the diver to perform complex skills automatically by providing opportunities for skill repetition
- enhance willingness to make changes to improve skills
- increase body awareness and spatial orientation
- work on skill parts while performing the whole skill
- improve lead-up skills to increase physical readiness
- slow down somersaults so diver may learn to see visual spots
- assist diver with proper body alignment
- shape body positions on skill initiation, flight and comeout
- cue diver with a light touch or verbal cue

### SPOTTING METHODS

By using hands, handbelts or overhead spotting belts in conjunction with body leverage, coaches may manually assist divers.

### HAND SPOTTING

Because most handspotting for diving is done on a one-skill-at-a-time basis, it is relatively easy to learn, especially for basic skills and single somersaults. Handspotting allows the

coach continuous control over the often unpredictable first attempts of the beginner. In spotting basic tumbling skills and somersaults, a rule of thumb is for the spotters to position themselves approximately at the midpoint between take-off and landing. Spotters must be ready to shift their weight in whatever direction the skill performance necessitates to insure a safe landing (Figure 7.2.1).

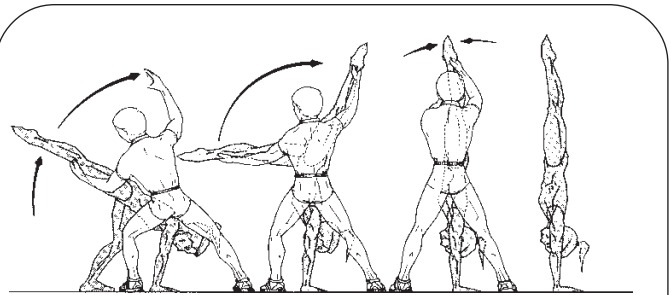

a. Spotter positioning for assisting the split kick armstand

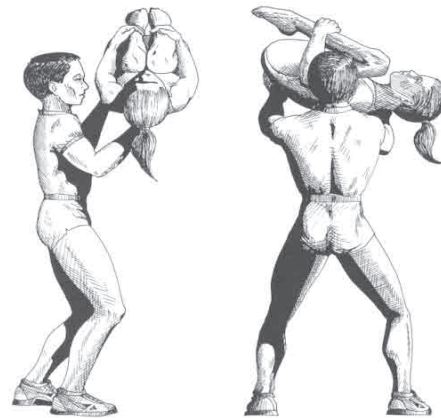

b. Positioning of spotter on the back somersault

Figure 7.2.1 Positioning of spotter for manual spotting

### Hand spotting variations

**Hands-on spotting.** This is a trampoline spotting method for advanced hand spotters. Since the spotter bounces with the diver, the timing and coordination is critical.

**Hands-off spotting.** The spotter does not spot the take-off or flight, but rather positions him/herself in readiness to assist on landing should a problem occur. This method might be used by diving coaches to reduce the stress of repeated landings during somersault training by “easing” the diver down to the landing area as a stepping stone to solo performance.

## Handspotting Landmarks

Coaches should know where to place the hands in spotting. Spotting landmarks are a special concern when the diver is a young female and the spotter is a male. The U.S. Diving Dive Safe program teaches coach members about placement of the hands during hand spotting basic skills on mats, sides of the pool and 1-meter springboard. Guidelines include:

- Know the spotting landmarks for the skill. Avoid any unnecessary touching.
- Handspotting at pool side and on the 1-meter springboard into the water require both face to face and face to back spotting configurations. Unlike the side spotting placement available on gymnastic mats, the spotter is limited by physical constraints imposed by spotting on the edge of the take-off surface.
- There are instances when a diver needs to be held by a handspotter; for example, a diver may be lifted and rotated by being held under the armpits, or may be lifted and stabilized by being held by the leg or arm.
- Make every effort to avoid spotting or touching **NO ZONES** (Whitlock, 1998) such as the diver's chest, buttocks or genital areas. In the Dive Safe program on the 1-meter springboard, the sternum is spotted as the last safety spot prior to solo performance of the inward dive. The purpose of the sternum spot is to push the diver away from the diving board in the event that he/she leans in dangerously close to the board.

## HANDHELD BELT

The handheld belt may be used for spotting single somersaults on the gymnastics mats or trampoline. This technique is particularly useful for introducing somersaulting as it allows more room for the unpredictable in performer error and requires less spotting expertise than the handspotting method (see Figure 7.2.2). Since two spotters are used, disparities in sizes between spotters and performers are minimized.

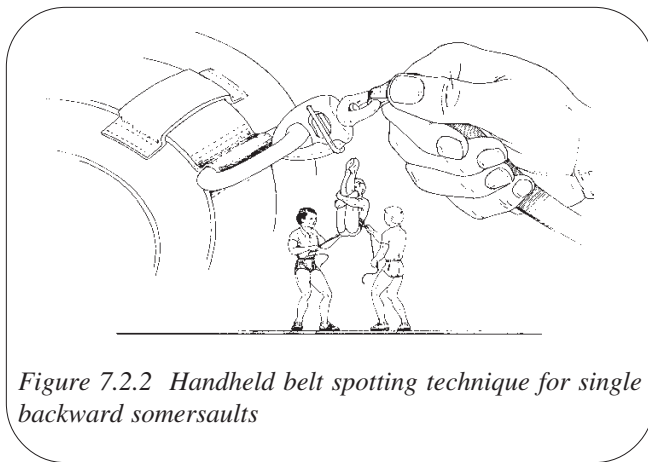

Figure 7.2.2 Handheld belt spotting technique for single backward somersaults

## OVERHEAD MOUNTED BELT SPOTTING

There are five spotting stations whereby diving coaches make use of overhead spotting rigs to aid divers in learning (1) trampoline, (2) dry board with portable landing pit, (3) low platform take-off runway, and (4) 1-meter or 3-meter wet board and (5) wet platform. The overhead mounted belt is the most versatile spotting method for competitive diving. Not only feet-first somersaulting skills but line-ups to the hands with arms overhead for head-first water entry are possible. The basic dives as well as somersaulting and twisting dives of increasing increments may also be simulated. In the belt, divers know they will be held up during the flight of the simulated dive. This fear-free environment allows them to concentrate on: (1) takeoff, (2) correct mechanics during the flight of the dive, (3) learning the use of the eyes during the spin or twist, and (4) developing the proper comeout action to line up for water entry.

## Landings

In dryland overhead belt spotting on trampoline, dry board and dry platform, landings are always spotted. As the spotter holds the diver up in an armstand landing position with arms overhead and hands flat for protection of the head, neck and spine upon landing, line-ups to the hands for head-first water entries are practiced. The diver is controlled down to the pit, and either steps out short to the feet or continues moving over to a stretched out flat back drop landing into the pit. Besides the armstand landing position into a portable landing pit, the back drop, front drop or seat drop landing positions are also possibilities, depending upon the demands of the skill being simulated.

## Entries

When overhead belt spotting is used at wet board or wet platform stations, the spotter lets the ropes slide through his/her hands while the diver enters the water.

## Skill Progression Reinforcement

Just as new skills may be taught by spotting, old skills may be reinforced to aid consistency of performance. This reinforcement is especially important in the learning progression after the diver has added another somersault or twist to the progression. For example, the tendency is for a diver performing a 105 to lose the feel for a 103 without continual reinforcement of the 103.

## Spatial Orientation

The greatest benefit from the use of the belts is the spatial orientation enhancement derived when the belts are used for repetitive skill training on a regular basis and for an extended period of time. Confidence, gained through constant repetition of a diving skill in the belt, is invaluable. The belts are also a great aid in making corrections for a diver who might be having a fear management problem on a dive because he/she has been "lost" (i.e. disoriented in a multiple somersault), or can't find the right place to come out on twisters.

## PREREQUISITES FOR THE SPOTTER

•Sufficient strength, agility and coordination to execute the spot.

•An accurate concept of the full potential of the skill. An ideal model concept promotes effective spotting.

•A thorough understanding of the force or momentum production involved in the initiation of the skill by the performer.

•A thorough understanding of the appropriate use of body segments to control the movement.

- hand placement
  - with respect to diver's CG
  - on the ropes for hand over hand pattern
  - sliding the ropes through the hand
- when to apply force (timing)
- how to lift the diver
  - use the legs, not the back
  - drop body down to lift diver up in the overhead belt
- be positioned to maximize the spot with respect to:
  - force application on take-off
  - elevated take-off surface height

•A thorough understanding of the completion phase of the skill, including come out and landing.

•An awareness of the more critical aspects of the skill.

## MATCHING METHOD WITH TASK DIFFICULTY

Each method of spotting requires an understanding of the appropriate body leverage and of other techniques unique to that method. It is the responsibility of the coach to employ the appropriate method. **The coaching decision as to which method is most suitable to a given situation depends on several interwoven factors: the number, size, age, experience and ability of the diver, the requirements of the skill, the ability, size and availability of the qualified spotter-coaches, and the equipment available.** Each method has its own safety equipment requirements for which the coach must assume responsibility.

Some skills may not require the spotting belt as the principal means of protection from a fall. The judgment of which protection method to use and when to use it is the coach's responsibility. Thus, whenever in doubt, it is far better to over-spot, especially on the landing than not. After the diver has gained confidence in his/her landing positions, the spotter may lighten up on the over-spot. When in doubt, use the highest level of protection available, until the performer demonstrates that he/she is ready to perform at a reduced level of protection (Sands, Cunningham, Johnson, Meek & George, 1988).

In the initial stages of complex skill learning, belt spotting is recommended, so as to minimize the peak G values

realized by the falling performer. Overhead belt spotting provides good fall protection and, compared with mats or foam pits alone, offers the greatest ability to slow a falling performer (Sands, Cunningham, Johnson, Meek, & George, 1988).

## KNOWLEDGE OF LIMITATIONS

### Heavy performer versus light spotter in overhead belt spotting

A falling body is heavier than one might suspect. Be sure that the spotter's weight and the weight of the performer are near enough so that the spotter with the use of the overhead spotting belt can reduce the performer's drop to zero within a couple of feet. As a general rule of thumb, a spotter should never attempt to spot a performer whose weight is far in excess of the spotter's (Trampoline Safety Manual, 1978).

**All other things being equal, consider using the heavier spotter whenever a performer is attempting a skill that may require instantaneous spotting assistance.**

There are other variables besides disparate weights to take into consideration. Appropriate spotting also involves assessing the performer's capability with the task's difficulty. Many highly skilled spotters who have mastered appropriate body leverage skills using the overhead mounted spotting belt are capable of safely belt spotting a diver heavier than him/herself. How much heavier depends on the spotter's weight and ability, the performer's weight and ability, and the demands of the task.

**A competent spotter recognizes his/her limitations and adopts safe spotting options.**

In overhead mounted belt spotting, a competent spotter may opt to spot a diver for the lead-up skill, and/or to a feet-first or basic drop landing, rather than to the armstand landing when necessary. Take-off mechanics and technique may still be practiced without a landing to the hands simulating head-first entry alignment with arms overhead. Because there are options available to the spotter that minimize the necessity for optimal weight ratios between a diver and spotter, the amount of force required to assist in performance remains well within the potential of most spotters of any size (George, 1980).

Anticipation of problematic circumstances requires constant vigilance. **The key to good judgment is the coach's knowledge of his/her own limitations.**

## COMMUNICATION

It is not enough to possess technical knowledge related to spotting. This knowledge must be communicated in a manner clearly understandable to the diver and the parent. Coaches must:

1. Explain the goals of spotting.

**•The primary goal of safety spotting is for the spotter to attempt to reduce the possibility of a serious or catastrophic injury by a fall on the head, neck or back.**

**•The secondary goal of safety spotting is the teaching of new skills.**

2. Warn about the possible risk of injury.

**•Spotting is not 100% fail-safe. Even in the best of situations, divers may still be injured while being spotted.**

**•Human beings are fallible. Errors on the part of the diver and/or spotter may occur.**

**•Equipment may fail.**

3. Explain the roles and expectations of the spotter and diver.

In some situations, the spotter may risk personal injury in order to safeguard the athlete, so in the best interest of safety for both spotter and athlete, it is important that the athletes understand that they must make their best effort to perform and land the skill appropriately.

**Spotting is a sacred trust between spotter and diver.**

4. Explain about spotting landmarks and misses.

•Occasionally, the coach may miss a spot and end up touching the diver in a NO ZONE. As long as this is a very infrequent, accidental occurrence, it is excusable. In these cases the coach and the diver both may be somewhat embarrassed. A simple "Oops! Sorry about that!" is a sufficient apology.

•In other situations, such as a very poorly executed attempt or a "miss" by the diver, the coach may find it necessary to spot whatever and wherever he/she can for the safety of the diver. This too is excusable and the diver should be aware that this can happen.

•Coaches too may be accidentally hit in a NO ZONE or injured by a diver during a spot. These situations may be embarrassing for both the diver and coach. Unless an injury results that requires first aid or other emergency response, it is probably the best strategy to minimize the situation.

It is very helpful for the coach to tell the diver:

- what visual cue(s) he/she should see, and
- what he/she should feel during the passage through the air
- a predetermined start signal
  - not to go unless the spotter is in place
  - not to go if the diver does not feel appropriate tension or slackness in the ropes
  - not to go if the spotter does not have his/her eyes on the diver. *(It is extremely difficult for the spotter to catch up with the diver once the action has commenced).*
- to avoid confusion by being clear on what skill is going to be spotted before the diver begins. The spotter should establish clear and accurate communications with the diver. It is vital that both the spotter and the performer know precisely what, when, where, how and why the skill is to be performed and spotted.

## SPOTTING SUGGESTIONS

•Check that the difficulty of the skill is appropriate to the capabilities and experiences of the diver. Extremely awkward spotting situations indicate that the skill is too complex for the diver's ability level and implies the necessity of lead-ups and progressions and/or increased physical readiness.

•Learn to spot performers of different sizes and abilities effectively and consistently on the most basic skills with the broadest application first, before progressively moving on to the more complex skills.

•Make every effort is to **read individual weaknesses and responses**. Learn what to expect from each diver.

•Appropriate supervision is a key to the diver's safety in the competitive diving environment. Divers should not be allowed on the dryland equipment without the coach's approval and presence.

- When handspotting difficult skills during the initial learning stages, provide continuous assistance throughout the entire skill.

- When handspotting, overspot when in doubt, but avoid undue overspotting. Creating a dependence on handspotting may slow a diver's progress towards skill mastery.

## REFERENCES

Gabriel JL, George GS, Kimball, D, O'Brien R, Xie C (1995) Dive Safe. Indianapolis, IN: U.S. Diving Publications.

George GS (1988) Spotting – a sacred trust. USGF Gymnastics Safety Update, 3: No. 1, p.1.

George GS (1980) Biomechanics of Women's Gymnastics. Englewood Cliffs, NJ: Prentice Hall, Inc., pp. 203-214.

Kimball D (1990) Spotting safety. In Gabriel JL, George GS (eds.): U.S. Diving Safety Manual. Indianapolis, IN: U.S. Diving Publications, pp. 141-148.

Milem, D.J. (1990) Spotting belts. In George GS (ed.): USGF Gymnastics Safety Manual (2nd ed.) Indianapolis, IN: USGF Publications, pp. 47-50.

Mitchell R, Longdon P (1985) Spotting and gymnastic safety. In George GS (ed.): USGF Gymnastics Safety Manual. Indianapolis, IN: USGF Publications, pp. 63-67.

Mitchell R, Longdon P (1994) Spotting and gymnastic safety. In George GS (ed.): USGF Gymnastics Safety Manual (2nd ed) Indianapolis, IN: USGF Publications, pp. 57-60.

Sands WA, Cunningham SJ, Johnson SC, Meek SG & George GS (1988) Levels of protection: gymnastics safety equipment, Technique 3 & 4: 20-24.

Schlosser T (1996) USA Trampoline and Tumbling Coaching the Fundamentals. Brownfield, TX: I.L. Cooper.

Trampoline Safety Manual (1988) Cedar Rapids, IA: Wagners Printers.

Whitlock S (1989) When is spotting appropriate? Gymnastics Safety Update, 4: (2) 5-6.

Whitlock S (1998) (ed.): USA Gymnastics Safety Handbook, Indianapolis, IN: USA Gymnastics Publications, pp. 47-50.

## Part 3. Overhead Mounted Belt Spotting Techniques

by Dick Kimball, M.A.

### ROPE WRAP TECHNIQUES

The technique of spotting dives from the back or inward dive groups is easier to learn than from the forward and reverse. The diver keeps the ropes behind his/her arms during the swing and back take-off. The spotter should keep the ropes taut while the diver is performing the take-off, and should then be ready to pull the ropes up as the diver leaves the board.

The spotting techniques used on forward or reverse take-offs are quite different and much more difficult to master. It is recommended that the beginning spotter observes these methods demonstrated by an expert before attempting them. If done incorrectly, it could be dangerous to the diver being spotted. It is also useful to have an experienced spotter "double-spot" by guiding the ropes for the beginning spotter.

There are two basic methods being used at the present time. Currently the most popular method is for the diver to wrap the rope around his/her arms in such a way that the rope unwinds and slides off, ending up behind the body as the arms are lifted up into the hurdle and swung around during the take-off. This method is easier for the spotter to learn. The diver needs to get used to the feeling of having the ropes wrapped around the arms during the approach and take-off.

When spotting front and reverse take-offs using the second method, the ropes have to be left loose as the diver takes an approach. The ropes remain loose until the diver hurdles, lands on the end of the board, and takes an arm swing. As soon as the arms are swung down and around, the spotter must pull up the slack in the rope, and get ready to control the diver during the lift off the board, in the execution of the dive and on the landing.

### LEARNING TO CONTROL SLACK

The trampoline is the preferred spotting station for acquisition of belt spotting skills. The diver being spotted on trampoline should be instructed to keep his/her arms in front of the ropes. The spotter controls the ropes so that there is a minimum amount of slack. The ropes are held taut by the spotter as the diver (in a basic belt) begins to take small repetitive bounces in the center of the trampoline. The ropes are kept taut during the bounce, but not held so tightly that the diver feels held up on the downward drop to the trampoline. If the spotter allows the ropes to become slack and gets "behind" in the spot, the timing of the spot will be missed. If the ropes are held taut, the spotter is ready at all times to control the diver. When the diver makes a mistake during the dive or has a weak take-off, the spotter will be able to hold the diver up for the landing. It is very important that the spotter never takes his/her eyes off the diver in the belts or loses

contact with the ropes while a diver is being spotted. **The spotter's primary responsibility is to land the diver safely.**

In order to control the slack, Shaffer (1988) recommends holding the ropes with both hands slightly above shoulder level. The non-dominant hand is placed above the dominant hand. The non-dominant hand grips lightly enough to allow the rope to slide through. The dominant hand pulls and lifts as the diver ascends and descends respectively. As the diver jumps up, the spotter pulls downward on the rope. As the diver descends from the peak of the jump, the dominant hand and the rope return to the starting position. The spotter will not add additional lift to the diver. The spotter should not allow an excessive amount of slack in the ropes, which would create a rough or jerking motion as the diver jumps. In most skills the spotter allows the diver to jump to maximum height while assisting the diver to create or maintain the somersault initiated from the take-off. With proper technique the diver should not feel any uncomfortable jerking on the ropes.

### BODY LEVERAGE

Shaffer (1988) describes the basic belt spotting technique on somersaulting and twisting skills as one which incorporates body leverage techniques. The spotter by flexing at the knees and hips and leaning backwards counterbalances the diver's weight. This body leverage technique is accompanied by a hand-over-hand pattern with the arms. The degree of knee flexion and amount of body leverage necessary are dependent upon several factors: the number of somersaults being performed, how the diver's size and weight compares to the spotter's, and the diver's skill level. A single somersault in most cases will take little effort by the spotter while a multiple spinning somersault may find the spotter applying so much leverage that he/she is practically supine to enable the diver to complete the revolutions. It is important that the spotter learn to use his/her entire body for leverage rather than to hold the diver up with only the arms. Proper use of body leverage enables a smaller spotter to spot a diver larger than him/herself. **Using body leverage effectively also enables the spotter to spot more advanced multiple somersaults and twists safely.**

### HAND-OVER-HAND PATTERN

Regardless of the number of somersaults performed, the hand-over-hand pattern remains the same (Shaffer, 1988).

### Ascent

At take-off, the spotter's arms are extended overhead with the non-dominant hand slightly higher than the dominant hand. As the diver begins to ascend, the spotter's dominant

hand begins to pull downward on the ropes. The non-dominant hand will remain overhead, allowing the ropes to slide through the hand. As the dominant hand finishes its pull at approximately waist level, the non-dominant hand grips the ropes to begin to pull down. When the non-dominant hand begins to pull downward, the spotter begins to flex at the knees and hips, and begins to lean backwards to help counterbalance the weight of the diver. The dominant hand releases and reaches overhead to regrip above the non-dominant hand. The body continues to flex and lean backwards. After the dominant hand regrips, both hands pull down and in towards spotter's body. At this point the diver has attained peak height.

## **Descent**

Safely controlling the diver's landing is the primary objective of the spotter. In the descent phase, as the diver completes the rotation, the spotter begins to stand up, counterbalancing the diver's weight, while keeping the arms close to the body.

## **TIPPING**

Once the spotter gains experience in handling the ropes, the ropes can actually be pulled in such a way as to aid the diver in bouncing and rotating the simulated dive. The term coined by the author for these maneuvers of pulling on the ropes to accelerate the diver's spin in the direction of the rotation around the spinning axis is "tipping." For any direction of multiple somersaulting, there is an active and a passive phase of tipping the somersault as it rotates around the axis. Keep in mind that the active and passive tipping phase terminology (Shaffer, 1988) refers to the position of the diver in the somersault and when the spotter will apply or not apply force to the ropes. Since the spotter must always control the ropes to land the diver safely, overhead mounted belt spotting is always an active rather than a passive activity.

## **Active Phase**

The *active tipping phase* is the period in which the hips pass through an imaginary vertical line and begin rotating upward from an upright (head up, hips down) to an inverted position. The *passive spotting phase* in the somersault is the period in which the hips pass through an imaginary vertical line and begin rotating downward from an inverted (head down, hips up) to an upright position. In the active phase the spotter can increase the amount of rotation by "tipping" or pulling down on the ropes, thus accelerating the body in the direction of the rotation. The amount of effort required to tip the diver during the active spotting phase is very minimal. It is more like a flick of the wrists while maintaining tension through the ropes.

## **Passive Phase**

During the passive tipping phase it is important to ease up somewhat on the ropes to allow the diver to continue to rotate.

Remember, no matter what mistakes are made during tipping, landing the diver safely is the primary objective.

By aiding the diver on lift and spin through the tipping technique, the spotter enables the diver to execute dives such as 107c,b, 109c, 205, 305, 405, 207, 307, 407 and any other dive imaginable under FINA guidelines. The experience of actually going through these dives and being able to learn the come-outs is a tremendously valuable teaching aid.

## **SPOTTING PROGRESSIONS**

The ability and readiness level of the spotter and diver limit what skills may be taught. The belts are teaching tools which complement progressions. Belts are not a substitute for proper teaching progressions. Spotting requires considerable practice in order to develop adequate proficiency in handling the ropes. The difficulty of the diving skill being spotted should be commensurate with the coach's spotting experience. If simple single somersaulting skills to the feet are being spotted, it is fairly easy to control the person in the belt. But, if more complex skills are being spotted to the hands, to or through the head-first water entry landing positions, the coach needs to have a complete knowledge of the mechanics, and be ready and able to hold the diver up during the execution of the skill and control the landing. Learning to spot should be achieved at the individual spotter's own pace. Learn to spot a new skill with a diver considerably lighter in weight (relative to the spotter) who can already perform the skill. Spotters should achieve skill mastery on a lighter diver before spotting a heavier diver or one with less ability. Spotters need to be comfortable and confident with their spotting proficiency before moving on to the next skill in the progression. For example, in the front somersaulting progression, after the coach masters the timing of the tip in the front somersault spot, the next step is the front one-and-a-half, tipping the diver over consistently well past the armstand and head-first entry line up to the back, before attempting the tip for the front double. Since front somersaults performed out of the belt in past noncompetitive trampoline usage have resulted in the majority of severe injuries which have occurred on the trampoline bed, spotters need to be aware of the importance of this spotting progression. The spotter must exercise caution when learning this spotting progression. It should be noted that the timing of the tip is the key factor. Strength should not be relied on in lieu of tipping expertise.

## **AREAS OF CONCERN**

### **Common mistakes**

Common mistakes made by beginning spotters include:

1. holding the ropes with too much slack.
2. trying to tip too early, causing the diver to stop in the middle of a somersaulting dive.
3. waiting too long to tip, and allowing the diver to land without controlling the landing.

4. causing the diver to lose balance by pulling the ropes unevenly or at the wrong time.

### **Additional spotting precautions**

In a dry land spotting situation the spotter may exceed the diver's tolerance by tipping the diver into multiple somersaults which greatly exceed competitive diving somersaulting demands. **Acceleration-produced retinal hemorrhages in normal individuals are relatively inconsequential, but the potential damage to the eye in divers with a congenital predisposition towards bleeding is great and may warrant explicit instructions to such divers and their parents about avoidance of these extended belt spotting activities** (Rabinovitch, McLean, Beck, & Brown, 1978).

## **BASIC GUIDELINES FOR SAFE AND EFFECTIVE SPOTTING**

### **Guidelines for the spotter**

- The spotter needs to be prepared physically by gradually getting into shape. Spot for short periods of time at first to gradually callous the hands. The arms, elbows, shoulders, back and legs also have to be in good condition to withstand the wear and tear placed on them.
- The spotter needs to have a thorough technical knowledge of the mechanics involved in the skill's execution.
- The spotter needs to have knowledge of the spotting techniques appropriate for the skill.
- The spotter needs to have an understanding of progressions and lead-ups involved in teaching and spotting skills.
- The spotter needs to check that the apparatus is in good working condition and is properly set up according to individual needs and the demands of learning situations.
- The spotter can work with only one diver in the belt at a time. It takes about ten minutes to spot a somersault workout and about five minutes to work on all the twisting dives. Plan workouts accordingly.
- The spotter may save time once the skills are learned by working with two divers at once. Have them alternate belts, so they can have a rest period between the somersaulting belt and the twisting belt.
- The spotter controls the dive's forward and lateral displacement while the diver performs in the belt.

### **Guidelines for the Diver**

1. The diver needs to report any equipment not in good working condition to the coach.

2. The diver needs to know how to wear belts properly. Divers need to be ready with the proper belt and spotting equipment secured when it is their turn.

3. The diver needs to be dressed appropriately for the activity. Jewelry is not recommended. A sweatshirt may be useful in preventing chafing of the arms from ropes.

4. The diver needs to be warmed up and in good physical condition before beginning training in the belts.

5. Before beginning the skill, the diver needs to check to see that the coach is in position and ready to spot.

6. Do not talk to or distract a coach while he/she is spotting.

7. Do not double-bounce the dry board out of the belt.

8. Only one person should be allowed on the board at a time.

9. Only use dry land equipment when a coach is present.

10. Permit absolutely no horseplay during workout/competition.

## **REFERENCES**

Kimball D (1983) Use of spotting rigs with trampoline, port-a-pit diving board, and regular pool one meter diving board. In Golden D (ed.): Proceedings of the U.S. Diving Sports Science Seminar, Indianapolis: U.S. Diving Publication, pp. 35-47.

Kimball D (1990) Overhead mounted belt spotting. In Gabriel JL, George GS (eds.): U.S. Diving Safety Manual. Indianapolis, IN: U.S. Diving Publications, pp. 155-157.

Kimball D (1992) *Instructional Video – Overhead Mounted Belt Spotting: Intermediate and advanced skills for competitive diving coaches on dry board, dryland platform and 1-meter.* Indianapolis, IN: U.S. Diving Educational Services, Item #101.

Rabinovitch P, McLean EB, Beck GR, Brown AC (1978) Recurrent preretinal hemorrhages following a negative "g" maneuver on school playground equipment. *J. Pediatr.* 92: 846-853.

Shaffer JS (1988) Learning how to spot; training in the use of an overhead spotting apparatus, In Proceedings of the Mission Bay Dive Clinic.

## Part 4. Landing and Entry

by Greg Louganis

Landing and entry are collision skills. The coach must provide ample opportunity for mastery of landing and water entry skills until these skills become automatic. Since gravity dictates a landing and/or water entry on every aerial maneuver, these skills have the broadest application to skill progressions in competitive diving. Although landing and water entry skills are the last skills in the sequence of a dive, they should be mastered first.

### LANDING SKILLS AND LEARNING TO FALL

Teach divers basic landing mechanics, how to recover from an off-balance landing and how to fall using proper matting and spotting before using elevated spotting stations for somersault training.

#### Landing Technique Drills

•Jump vertically in place, landing first on the balls of the feet and then on the heels (an almost flat-footed landing).

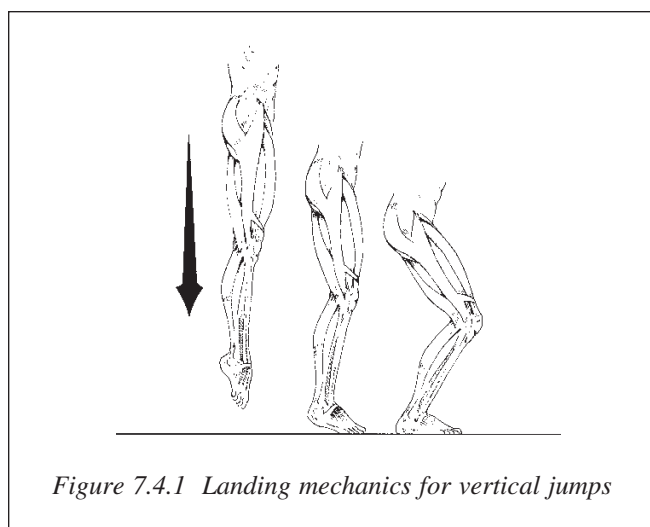

Figure 7.4.1 Landing mechanics for vertical jumps

-Discourage landing completely flat-footed or primarily on the toes. Emphasize bending sufficiently at the ankles, knees and hips to absorb the landing shock, without hyperflexion in the knee joint (see Figure 7.4.1).

-Stress proper use of arms for balance and appearance.

-NEVER land feet-first with locked knees.

-Stress a rounded, not arched back.

•Jump forward, backward and at a slight diagonal and land with proper technique (see Figure 7.4.2).

#### Drills for recovery from off-balance positions

Jump forward, backward and on a diagonal, landing slightly off-balance and recovering by doing a forward, backward or shoulder roll (see Figure 7.4.3), whichever is appropriate to the situation (Calkin, 1985).

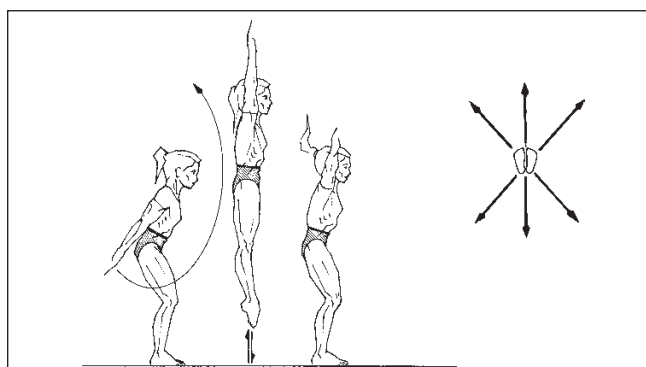

Figure 7.4.2 Landing forward, backward and diagonal jumps

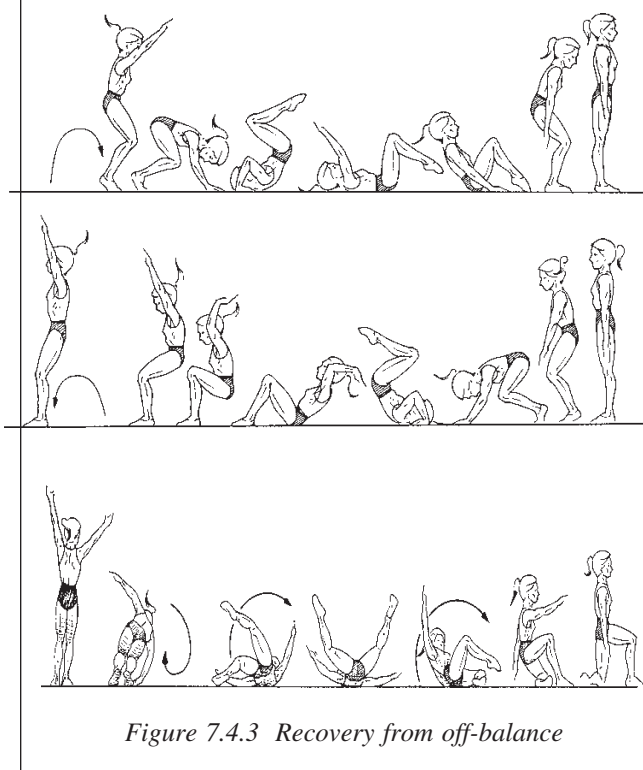

Figure 7.4.3 Recovery from off-balance

- Teach divers to protect the head and neck with the arms and back when rolling backwards.

- Stress proper placement of the hands on the sit-back phase of the backward roll. The hands should be placed on the mat with the fingers facing forward so that the elbow can “hinge.”

- On the shoulder roll stress rolling across shoulders and back. This is similar to the side roll taught in karate or judo. Emphasize the arms and back forming a ‘roll cage’ to protect the head and neck (see Figure 7.4.4).

- Jump vertically in place with a 1/4, 1/2, 3/4 and full twist. Practice in both twist directions. Recover or roll on the mat if the landing is not perpendicular to the ground to protect the knee joint.

### Fall recovery

- Backward rotating fall.** Roll back into a cradle position.
  - Emphasize that the arms and back be in position before the head contacts the mat. The arms and back form a “roll cage” to protect the head and neck.

- The back of the hands are presented to the mat as an extension of the arms. The palm is in position to push against the mat. Avoid reaching the arms behind the body with the elbows locked.

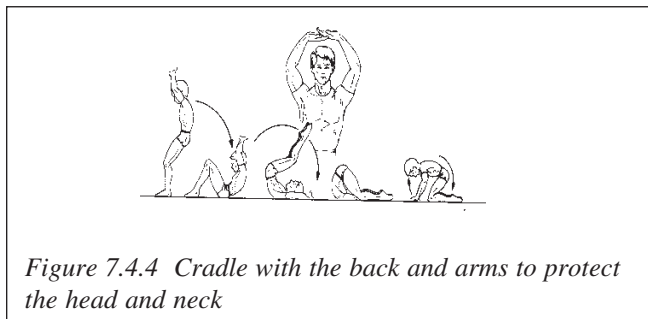

Figure 7.4.4 Cradle with the back and arms to protect the head and neck

- Fall forward to a prone position.**

- First use some hip and knee bend.
- Repeat with a completely straight body and absorb the shock by bending the arms (see Figure 7.4.5)

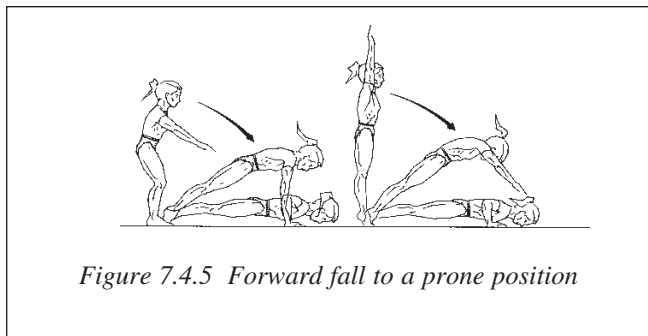

Figure 7.4.5 Forward fall to a prone position

- Skill progression for recovery from a fall from a handstand
  - Do a cartwheel (see Figure 7.4.6)
  - Arch over contacting the mat with the feet
  - Forward roll out.

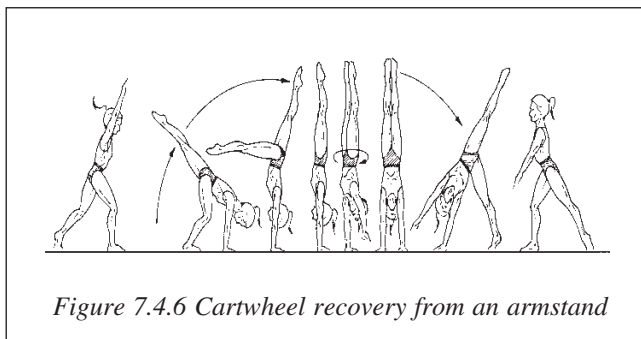

Figure 7.4.6 Cartwheel recovery from an armstand

### BASIC SAFE LANDING POSITIONS (SLP) FOR DRY BOARD & DRY PLATFORM INTO PORTABLE LANDING PIT AND TRAMPOLINE

Basic landing skills have a positive transfer of learning to the trampoline and dry board training stations. In addition to feet first landings, divers may land on other body surfaces besides the feet.

#### Armstand landing variations in the overhead spotting belt

**WARNING:** The armstand landing position to the hands that simulates head-first water entries with arms overhead on dry board into a portable landing pit or trampoline is ALWAYS practiced in the safety belt with a competent spotter controlling the ropes. The spotter holds the diver up in an armstand landing position while the diver keeps the arms overhead and hands flat to support the body weight upon landing. When simulating head-first water entry line ups in the safety belt on the dry board into the portable landing pit and trampoline, the diver should always keep the hands overhead for protection of the head, neck and spine throughout the armstand landing. The diver is controlled down to the portable landing pit or trampoline and either steps out short to the feet or performs a forward roll to the feet, or continues moving over through an armstand to a flat back landing position into the portable landing pit or trampoline bed. After demonstrating control in landing the armstand position, the diver lets the weight drop and settle into the portable landing pit rather than trying to hold an armstand. This procedure will avoid swinging back into the board, especially on the inward group (Figure 7.4.7).

#### Basic Drops

The back drop, front drop and seat drop are also used, depending on the demands of the skills being simulated and what the skill emphasis is (see Figure 7.4.8).

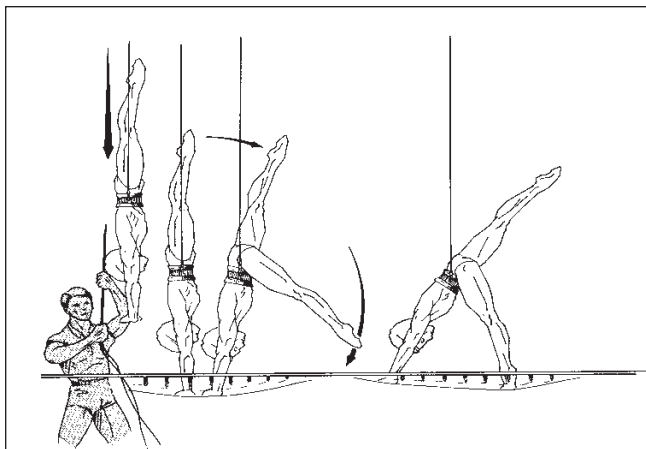

a. Armstand step down

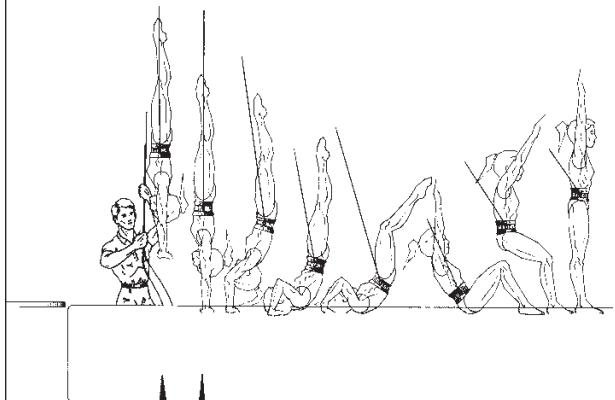

b. Armstand forward roll

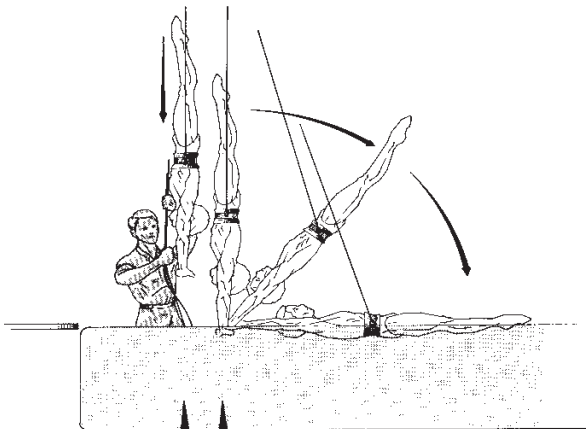

c. Armstand to flat back

Figure 7.4.7 Armstand landing skills with overhead belt spotting into trampoline or portable landing pit

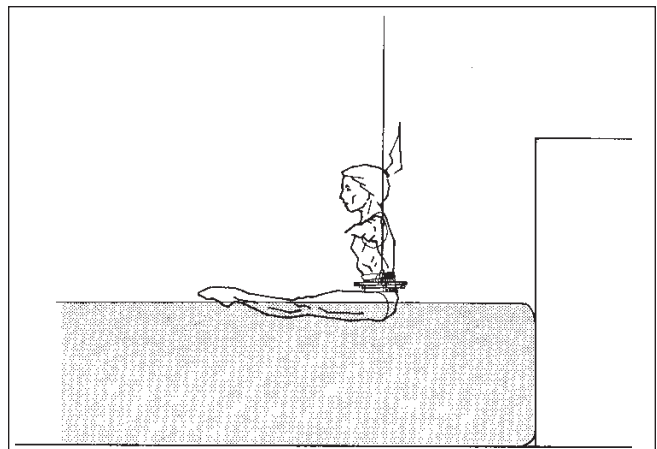

a. Seat drop

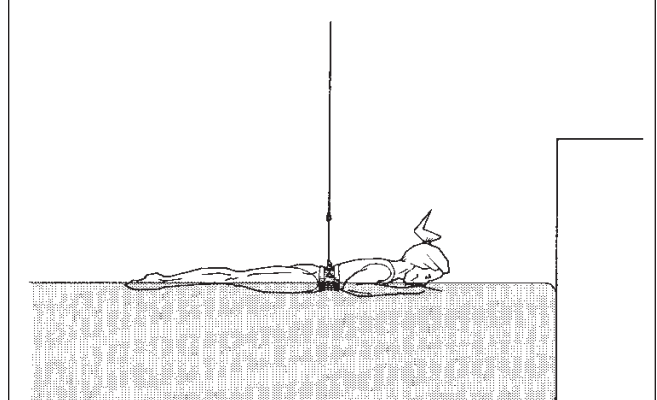

b. Face drop

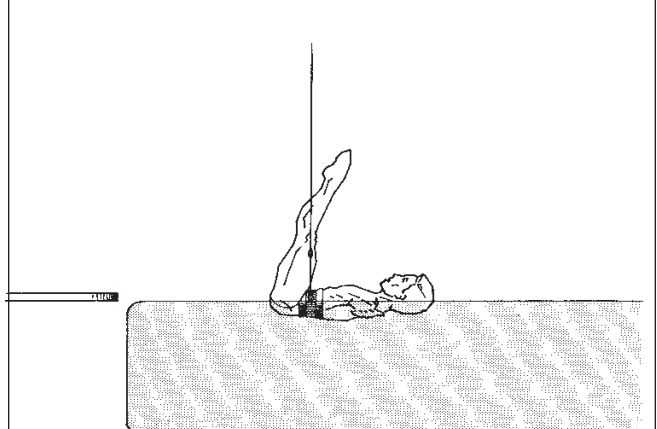

c. Back drop

Figure 7.4.8 Basic landing positions in the safety belt on dry board into the portable landing pit and trampoline. The seat drop position is commonly used to practice the square out of a twister.

## **WATER ENTRY**

### **Shallow water entry spinal cord injury profile**

Every year about 2 million Americans have a head injury or spinal injury with a severity that warrants medical care (American Red Cross (1995)). Fatalities and quadriplegia sustained from head-first entries into shallow water are irrevocably tragic. Through safety awareness, training and supervision the incidence of these tragedies may be reduced. The sport of competitive diving has suffered a poor image due to the name association of 'diving' with accidents which involve a head-first dive into shallow water, but have no connection to the sport of competitive diving. Some facts about this dangerous shallow water diving activity include:

Facts from the National Spinal Cord Injury Statistical Center University of Alabama, Birmingham (1998)

◆Of all spinal cord injuries (SCI), about 11.4 percent are sports-related.

◆Of these sports-related SCI, about sixty-six percent resulted from 'diving', *most from head-first entry into shallow water.*

◆Males are more likely to suffer this type of injury than females. Of these 'diving' SCI, 92 percent involved males and eight percent females.

Facts from 360 pool related diving injuries of which 95 percent resulted in quadriplegia. Gabrielsen & Spivey (1990)

◆The majority (93%) of SCI victims dived into shallow water five feet deep or less. The rest of the victim's points of impact were in mid-deep water 5'1" to 7' deep.

◆The majority (88%) were between the ages of 13-33. The mean weight for males was 175 lbs and for females 124 lbs.

◆The majority (84%) of 'diving' SCI victims were not properly supervised.

◆Most (93%) were removed from the pool without a spineboard by friends who were not aware the victim's neck was fractured.

◆About half(48%) of all cases involved alcohol/drug ingestion.

### **Spinal cord injury mechanism**

Neck loads with the head 'ducked' at impact have been studied in recreational swimming involving head-first dives into shallow water (McElhaney, Snyder, States & Gabrielsen, 1979, Tator and Palm, 1981; and Stone 1982). Diving spinal cord injuries (SCI) are usually the result of flexion or flexion-rotation, (i.e. head 'ducked' at impact with the bottom of the pool), injuries generally associated with compression fractures/dislocations that cause direct injury to the spinal cord at that site. The motor and sensory impairment that results is based on the location of injury in the spinal cord. If a diving accident

results in injury at the C4 level of the cervical spine, all of the functions at or below that level could be affected resulting in temporary or permanent paralysis, or death (Scotzin, 1985).

### **Water depth and spinal cord injury**

The risk of spinal cord injury can never be eliminated in any practical diving pool design. Running entries from a 1-meter board (Stone, 1982) and even standing dives from the deck (Blanksby, Wearne, Elliott, 1996) into deep water that meets the FINA 1-meter springboard minimum water depth dimension of 3.4 meters may generate sufficient force (300 pounds) to dislocate or crush cervical vertebra with the cervical spine flexed. Stone (1982) calculated it would take pools built about twice as deep as the minimum currently recommended by FINA under a 1-meter springboard to eliminate the risk of injury from potential head impact with the pool bottom. Such an overbuilt diving area design is considered impractical. FINA dimensions do not even recommend that much depth under a 10-meter platform.

### **Spinal cord Injury Control Strategies**

Since there is no record of a fatality or catastrophic injury connected with a supervised training session or diving competition in 100 years of competitive diving in the U.S., **competitive diving is not considered to be a high risk sport.** However, since collision with the pool bottom at whatever depth poses a risk of damage to the cervical vertebrae, U.S. Diving recommends the following strategies to prevent spinal cord injuries:

• **There is a basic requirement to steer underwater to avoid potentially injurious impact with the bottom in any practical pool.**

• **A competitive diver must know how much room to maneuver the water envelope provides.** Divers need to be aware of the pool bottom configuration and the depth under, ahead and to each side of the board or platform before diving. Divers and coaches are urged to familiarize themselves fully with the actual dimensions of any new pool before making head-first entries.

• Hold all practice sessions in pools which comply with the minimum depth and other dimensions set forth in the U.S. Diving Rules and Regulations.

• If any pool is used for practice which does not meet these dimensions, all divers and coaches using the pool for the first time should be advised of the nonconforming dimensions of the practice pool, particularly those affecting room to maneuver underwater (see: H—water depth at plummet; A—from plummet back to pool wall ; J-K—distance & depth ahead of plummet and L-M—distance & depth each side of plummet).

• If the diver feels he/she is not able to maneuver in any depth, be it 9 or 12 feet, the decision should be made in that situation not to dive; or if the decision is to dive, then the decision must

be made voluntarily with full appreciation and assumption of the potential risk of serious injury, paralysis or death.

- Divers who regularly train in nonconforming pools are usually well aware of their pool's limitations and govern themselves accordingly. Divers and coaches who are new to any nonconforming practice pool must be particularly warned about the pool's limitations.

- Teach divers not to dive in head-first or jump feet first to enter an unfamiliar pool, lake, river or ocean. Instead, teach divers to wade in or ease in.**

- Enter the deep water in the diving area feet-first the first time in an unfamiliar competitive diving facility.**

- Teach beginning divers to dive in deep water (9 feet deep or more). Teach them a nearly horizontal entry and a steer up.

- In regard to water depth, teach divers to match task difficulty with skill competency on every dive especially after a layoff, growth spurt or illness.

### 10-meter platform entry impact

Entrance velocities increase as the height increases. Entries from 10 meter platforms reach entrance velocities of about 32 mph or 14.16 m/s. The average impact force for a well executed 10 meter platform dive varies from 20 G's to 24 G's with a time to peak acceleration of 100 milliseconds (Stevenson, 1983). G's identifies the magnitude of force in relation to the gravitational force on the body which is equivalent to  $9.8 \text{ m/s}^2$ . For example, 24 G's means that the force is equivalent to 24 times the gravitational force ( $1G = 9.8 \text{ m/s}^2$ ). Stapp (1949, 1951) reported a threshold of danger in whole body accelerations of 35-50Gs. Stevenson related peak acceleration and duration of peak acceleration data from the 10 meter platform impact to a model for human tolerance.

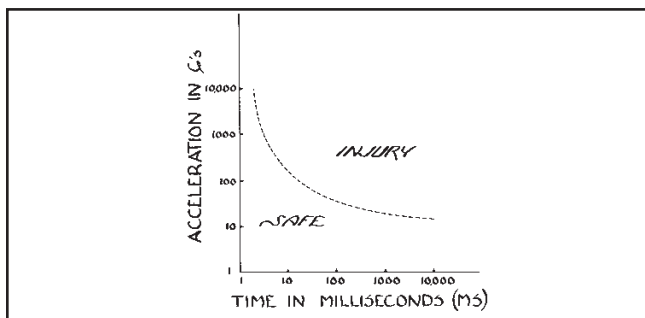

Figure 7.4.9. Relation between acceleration and time required to produce human injury. Note that a well executed 10 meter dive with an acceleration force of 24 G's with a time to peak duration of 100 milliseconds falls with the safe area under the curve. Stevenson (1983) modified from Lissner et al (1960) Acceleration and intracranial pressure changes.

The idealized graph modified from the Lissner study in Figure 7.4.9 shows that:

- High accelerations can only be tolerated without injury when the time duration of impact is short.

- Low impact forces can be tolerated without injury for a longer duration.

---

States (1976) assisted General Motors with human tolerance studies by collecting data on 72 year old Henri LaMothe, a stunt diver who regularly performed a belly flop with back arched from a height of 10.4 meters into 18 inches of water without sustaining injury. Most of the velocity of the dive was lost in the first 3 to 4 inches of water penetration. The high G force of impact at his sternum, the initial impact point, was 380 G's. The total chest area received 69 G's of force. LaMothe was able to tolerate high accelerations without injury by tensing the muscles to load the blow over as much of the body as possible, thus reducing the duration of impact.

---

In order to prepare divers properly for platform entries, coaches should be aware that:

- Whether a hit or a miss, rigidity at impact is essential to protect the body from injury** (Schneider, 1962).

- A single misaligned dive, repetitive submaximal trauma or diving when fatigued could have a bearing on tolerance of individuals to impact forces of a given magnitude, direction or duration.

- Injury may result when one part of the body is decelerated at one rate while another part of the body is decelerated at another (Sands, Cunningham, Johnson, Meek, & George, 1988), such as on an entry when an arm gets caught behind the head and back after the "swim," resulting in shoulder dislocation.

- Any technique (a "swim" or an underwater save) that exposes a greater cross-sectional area to the water will increase the magnitude of force of the entry, if executed before the feet disappear through the surface. It is difficult to derive how the force is distributed to the more vulnerable areas (such as the lower back or shoulders) because of the natural "give" of tissue and joints in the human body (Stevenson, 1983).

- Thumb and wrist injuries are common among platform divers and are related to the "rip" entry, which involves the "swim" technique (Rubin, 1987). Mathematically, it has been derived that a "swim" produces 3.6 times greater magnitude of force than an entry without a "swim" (Stevenson, 1983).

## Body alignment for safe 10 meter entries

Entrance velocities from 10 meters demand considerable strength in the shoulder girdle, arms, wrists and back to maintain the proper entry alignment. Learning the proper body alignment and conditioning the body to maintain this alignment under the forces of impact are gradual processes. It takes practice for the body to adapt itself to these conditions (Rackham, 1975). Given the risk of lower back injury and the additional force the shoulders must withstand due to the “swim,” the safety-conscious coach will pay attention to proper body alignment to prevent injury (Gruber, 1982, Mangine, 1982). Coaches should:

- Understand that the hands grabbed and thumbs interlocked in combination with a hollowed trunk with arms overhead is critical to protecting the head, neck and spine at entry.
  - Have divers rehearse the mechanics of entry in a static dryland situation, so that the diver masters the proper shape and sequence of movements before having to replicate them in a dynamic situation.
  - Understand the role of the armstand in teaching proper body alignment in an inverted position.
- Posterior pelvic girdle rotation aligns the lower half of the body with the upper half. Rotate the arms slightly inward to align the arms with the trunk, and place the head directly between the arms (see Figure 7.4.10).

Figure 7.4.10 Comparison of good versus poor armstand body alignment technique (George, 1980)



- The combination of the techniques of elevation and hollowing of the shoulder girdle increases stability in the armstand (George, 1980) inverted entry position (see Figure 7.4.11). The shoulders are raised as high as possible to fully elevate the shoulder girdle toward the ears to attain a completely stretched position with the greatest distance possible between the hands and the feet.

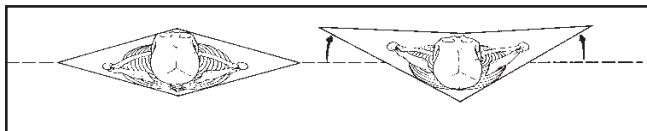

Figure 7.4.11 Flat versus hollowed shoulder girdle shape on armstand and forward/inward head-first entries (adapted from George (1980))

- Understand that the goal on forward lineups is to enter slightly short of vertical to avoid an arched back at entry from over rotation (Brown & Abraham, 1983).

## PLATFORM COMPETITIVE ENTRY GUIDELINES

*(The underlined points are guidelines developed by the American Academy of Pediatric for working with young athletes (Stevenson, 1983)).*

- Adequate abdominal, back, shoulder and wrist strength commensurate with the nature of the skill, the height of the event and the age of the competitor needs to be achieved. Children's strength is not necessarily proportional to their size. In addition, they often lack motivation on conditioning for strength and endurance, and lack patience about restrictions on activities.

- Since the body can withstand impact in the feet-first entry position better than head-first, acclimate a diver to the forces of entry by mastering feet first jumps at higher heights.

- Divers' entry skill progressions should include both vertical lineup and horizontal “impact” drills. Play the jump or dive game to teach recovery and rigidity.

- Master body control on the basic lineups from low heights before gradually acclimating the body to withstand impact from greater heights.

- It is difficult to recognize congenital problems in children: avoid their landing on the water with the back in an arched position. Keep the hips tilted under for protection.

- Since the flexible ligaments and open epiphyses (incomplete bone growth) of children could lead to musculoskeletal injuries, emphasis should be placed on lead-up skill proficiency, consistency and proper alignment at the lower heights before proceeding to the 10 meter.

- **Consideration should be given to wearing protective equipment only if an injury is present; otherwise, it may become a “crutch.” The hexcelite thumb brace may be used early when learning platform diving for short periods, especially in younger developmental platform divers. Children are uninterested in using protective equipment.**

- **Avoid overtraining. To protect against chronic trauma which could result from repeated impacts of high magnitude, limit the number of platform dives executed each session.** The total amount of activity including strength and conditioning must be considered to prevent injury due to fatigue. Reduce risk by:

- ceasing to practice dives from a given dive group until the next session if the coach observes that the diver is fatiguing or failing too many entries in that group.

- practicing the bulk of the repetitions (i.e. lead-ups) at lower than the workout height.

- subtracting one dive from the total number of entries the coach allows the diver to perform for every lineup practiced at that height.

## REFERENCES

- American Red Cross (1996) Safety Training for Swim Coaches. St. Louis, MO: Mosby Lifeline, p. 7.
- Blanksby BA, Wearne FK, Elliott BC (1996) Safe depths for teaching children to dive. *The Australian Journal of Science and Medicine in Sport*, 28: 79-85.
- Brown JG, Abraham LD (1983) The role of whip in rip entries. In Golden D (ed.): *Proceedings of the U.S. Diving Sports Science Seminar*. Indianapolis: U.S. Diving Publication, pp. 3-14.
- Calkin, J. Teaching landing techniques. In G.S. George (Ed.), *USGF Gymnastics safety manual*. Indianapolis: The USGF Publications Department, 1985, 82-83.
- DeMers G (1994) To dive or not to dive: What depth is safe? *JOPERD*, April: 17-22.
- Egstrom GH, Rowley WN & Wilson RR (1986) *Alcohol and Diving Performance*, University of California, Los Angeles, Department of Kinesiology, 1986.
- Gabriel JL (1992) *Diving Safety, a Position Paper*. Indianapolis, IN: US Diving Publication.
- Gabrielsen M, Spivey M (1990) *Diving Injuries: The Etiology of 486 Case studies with Recommendations for Needed Action*. Fort Lauderdale, FL: Nova University Press, p. 4-8.
- George GS (1980) *Biomechanics of Women's Gymnastics*. Englewood Cliffs, N.J.: Prentice Hall, Inc.
- Gruber FW (1982) The body alignment of classical ballet applied to springboard diving. In the *Proceedings of 1988 Mission Bay Dive Clinic*.
- Lissner HR, Lebow M, Evans EG (1960) Experimental studies on the relationship between acceleration and intracranial pressure changes in men. *Surg. Gynec. Obstet.* 111: 329-338.
- Louganis G (1990) Landing and entry. In Gabriel JL, George GS (eds.): *U.S. Diving Safety Manual*. Indianapolis, IN: U.S. Diving Publications, pp 105-116.
- Mangine RE (1982) Preventative exercises for the back in the competitive diver. In Golden D (ed.): *Proceedings of the U.S. Diving Sports Science Seminar*, Indianapolis: U.S. Diving, pp. 91-99.
- McElhaney J, Snyder RG, States JD, Gabrielsen MA (1979) Biomechanical analysis of swimming pool injuries. In *The Human Neck: Anatomy, Injury Mechanisms and Biomechanics*, No. SP-438. Warrendale, PA: Society of Automotive Engineers.
- Facts at a glance (1998). National Spinal Cord Injury Statistical Center, Birmingham, AL. Annual Statistical Report, December, 1998. In *Spinal Cord Injury: Clinical Outcomes from the Model System*. Available through Aspen Publishers, Order #20697 1-800-638-8437.
- Rackham G (1975) *Diving complete*. London: Faber and Faber LTD.
- Sands WA, Cunningham SJ, Johnson SC, Meek SG, George GS (1988) Levels of protection: gymnastics safety equipment, Technique, 3 & 4: 20-24.
- Schneider RC, Papo M, Alvarez CS (1962) The effects of chronic recurrent spinal trauma in high diving. A study of Acapulco's divers. *J. Bone and Joint Surg.* 44-A: 648-656.
- Scotzin M (1985) New York regional spinal cord injury system, Rusk Institute of Rehabilitative Medicine. In *Proceedings of the National Pool and Spa Safety Conference*, co-sponsored by the U.S. Consumer Product Safety Commission and the National Spa and Pool Institute. Arlington, VA, May 14, p.36.
- Stapp JP (1949) Human response to linear acceleration: Part I. Preliminary survey of aft facing seated position. Air Force Technical Report Number 5915, Part 1.
- Stapp JP (1951) Human exposures to linear deceleration: Part II. The forward facing position and the development of a crash harness. Air Force Technical Report Number 5915, Part 2.
- States M (1976) Daredevil dives aid safety study. *Physician and Sports Medicine*, 4 (8): 20.
- Stevenson JM (1983) The impact force of entry in diving from a ten meter tower. In Winter DA et (eds): *Biomechanics IX - B*, Champaign, IL: Human Kinetics. pp. 106-111.
- Stone RS (1980) Detailed diving studies by Dr. Richard S. Stone of Arthur D. Little, Inc. National Swimming Pool Foundation (NSPF) publication, 1.1-1.2. (Available as a set of 10 studies from NSPF, 10803 Gulfdale, Suite 300, San Antonio, TX 78216 (512) 525-1227).
- Tator CH, Palm J (1981) Spinal injuries in diving: Incidence high and rising. *Ontario Medical Review*. 48: 628-631.
- Werner G (1998) *FINA Handbook*, pp. 378-379.
- Whitlock S (1998) *USA Gymnastics Safety Handbook*. Indianapolis, IN: USA Gymnastics Publications, pp 45-46.

# Part 5. Body Awareness and Spatial Orientation

by Micki King

The primary safety objective in competitive diving is safe board/platform clearance on every dive. The secondary safety objective is completing the desired rotations. **Spatial orientation** is the ability of the diver to know the position of his/her body relative to the diving board and the water. That is, the diver must always know, no matter how complicated the movement, exactly which way is up and which is down. **Body awareness** is the ability of the diver to control the body positions and shapes while somersaulting and twisting in the air. The development of a diver's spatial orientation and body awareness helps him/her meet the safety objectives of the sport.

Disorientation and a lack of body awareness during a dive may result in injury. Divers must learn to stay oriented to the vertical throughout the dive to prevent disorientation. In the event that a diver becomes disoriented during a dive, it is imperative that he/she make quick reactive adjustments to protect him/herself. For example, too much backward lean toward the fulcrum on a reverse take-off could place the diver at risk of striking the board. A diver well trained in spatial orientation is better able to perceive the mistake and jump away from the board. In addition, during the airborne phase, the kick-out and arm reach for the water may be delayed or adapted to avoid striking the hands or head on the board.

A disoriented diver may not complete the desired amount of rotation and risk injury during entry. Body awareness of a proper tuck and pike position may facilitate somersault completion. Body awareness promotes proper body alignment (with the hips under) during board recoil and entry that may reduce the risk of lower back injury.

## SENSORY SYSTEMS

Body awareness and spatial orientation are inextricably related, and as such are developed in concert with one another. Body awareness and spatial orientation have been described as a function of the **integrated** activities of three sensory systems: visual, vestibular and somatosensory (Campbell, 1967; Shupert, Lindblad, & Leibowitz, 1983). These sensory systems include:

•**Visual.** The eyes provide perception of horizontal, vertical, speed, direction and distance references.

•**Vestibular.** The gravity receptors in the inner ear (semicircular canals and otolith organs) sense alterations in the position of the head during linear and rotational acceleration and deceleration.

•**Somatosensory.** Pressure and tension receptors combined with proprioceptive (kinesthetic) sense receptors found in the muscles, joints, tendons, viscera, etc. provide feedback which determine the relative position, tension and speed of the *limbs and body parts*.

## Progressive Stages of Development

Body awareness and spatial orientation are developed in concert with one another. After a transitory period (between the ages of 4-6 years), the nervous system develops mature postural control based on visual, vestibular, and somatosensory integration responses by the age of 7-10 years. More fine tuning of sensory integration occurs between the ages of 11 and 16 years. Since these progressive stages of development are alterable by appropriate training, age group divers should spend a large amount of their training time in dry land training, practicing appropriate skill progressions and lead-ups, to facilitate development of these mechanisms.

Skill progressions, that are methodically and gradually introduced, enhance safety by building on the existing organization and integration of sensory perception already established in the central nervous system. Many new or young divers lack exposure to a broad range of basic movement experiences on the ground. Body awareness is developed by exposing the diver to:

•**Basic locomotor movements** (walking, running, hopping, skipping, jumping, leaping and climbing) to develop mature movement patterns with carry-over to diving approach and take-off skills.

•**Basic body alignment.**

-Posterior pelvic rotation (hips under) aligns the upper body with the lower body.

-Countering posterior pelvic rotation with the proper positioning of the ribs with respect to the spine contributes additional stability.

-Improper body alignment can be a limiting factor in how far a diver may advance in the skill progression.

-Improper body alignment may also contribute to injury. Coaches should pay attention to body alignment, particularly in the take-off phase (diver upright) as well as in the head-first water entry phase (diver inverted), when the body is subjected to maximal force.

•**Basic body positions**-tuck, pike and straight.

•**Basic shapes**-dynamically curved forward and backward hollow and arch shapes.

Teaching body alignment, positions and shapes should begin on the ground, not in the air. Practice body alignment, positions and shapes upright, inverted, hanging from a bar, prone, supine, etc. (Roth, 1985).

Ballet training for divers (Pruett, 1981) enhances: 1) body awareness, 2) accuracy in finding a centered alignment, 3) placement and execution of twisting/turning skills, and 4) awareness of the skills of locomotion for the approach and postural stability in divers (Gruber, 1982).

Divers should master the basic diving positions and shapes on simple skills before moving to complex ones. Before moving on in the skill progression, the diver should be able to demonstrate that he/she is able to:

- assume and maintain the position/shape
- move quickly into and out of the position/shape
- maintain the position/shape under stress.

Since humans are “pre-wired” for upright posture, position sense tends to be more precise with vision rather than blindfolded, upright rather than inverted, in the forward rotational direction rather than backward, and in the layout position rather than tuck. Competitive diving requires a radical departure from the usual upright position to which people are already accustomed. Diving requires precise orientation throughout skill progressions in which divers rotate both forward and backward from (1) a stand – both upright and inverted (armstand) or (2) a forward approach, (3) traveling through the air in one of four possible positions, (4) entering the water either feet-first or head-first. The demands for versatility which the structure of the competitive contest imposes, emphasizes the role of spatial orientation training in the safe execution of dives throughout front, back, reverse, inward, twists and armstand skill progressions. Spatial orientation is developed by moving through shapes and positions in the air. Start with basic jumps in all positions before moving to dives, somersaults and twists.

### Visual Spotting

**Spotting** is the term used to describe visual contact with an appropriate point in the environment while performing a dive. Just as ballet dancers and figure skaters deliberately fixate on a visual reference point as long as possible during a turn (Dix and Hood, 1969), so too should divers spot during somersaults. Spotting can be useful in suppressing the disorientation that could occur during rapid somersaulting maneuvers. Spotting is also useful in identifying the position and orientation of the diver’s body in space (Shupert, Lindblad, & Leibowitz, 1983). Rather than diving in fear (with eyes closed), divers should be taught to open their eyes and “spot” at appropriate times during the somersault. This will enhance orientation, and thus safety. During a simple front dive, spotting is easy enough. The diver focuses on the end of the board, then, after take-off, refocuses on the water below. However, on the more difficult dives, spotting becomes increasingly more complicated and even more critical to safety.

It is the body’s acceleration during a somersaulting dive that makes spotting so critical. On multiple somersaulting dives in the forward and reverse group the diver spots or tracks a spot zone between pool edge and entry point. On back and inward groups, the diver spots or tracks a spot zone between the board/platform and the entry point. It is not recommended to spot a wall, or object common only to a diver’s home pool,

since that same spot may not be present when diving away from home. The board and the water will always be there and in the same place.

Divers who develop the habit of visually monitoring the water or board while rotating develop more trust in the information they receive. The coach should verify that the diver is consciously looking for his/her spot to adjust the angular velocity change from dive to dive. The verification spotting provides the diver, as acceleration forces increase along with degree of difficulty, is similar to the pilot switching to the instrument panel to prevent disorientation.

### Head orientation at take-off

The location and function of the vestibular receptors in the inner ear make proper head orientation a safety priority. When balance of youngsters is threatened, the head appears to remain frozen due to a “startle” response. In contrast, under the same balance-threatening conditions the more experienced gymnastic performer has been found to separate or “uncouple” the head to maintain its orientation to the vertical, and thereby prevent falling (Woollacott, Debu, and Mowatt, 1987 and Debu & Woollacott, 1988). Thus it appears that head orientation is extremely important for maintaining orientation to the vertical. In the two so-called blind entry dive groups, backward and reverse, the head may tilt back slightly during take-off to activate the neck righting reflexes that facilitate an armswing overhead with straight elbows. However, diving coaches should be aware of the importance of maintaining head orientation to the vertical at last contact. This head orientation to the vertical should be maintained, despite the tendency for the unschooled diver to orient the head in the direction of the rotation (see Figure 7.5.1).

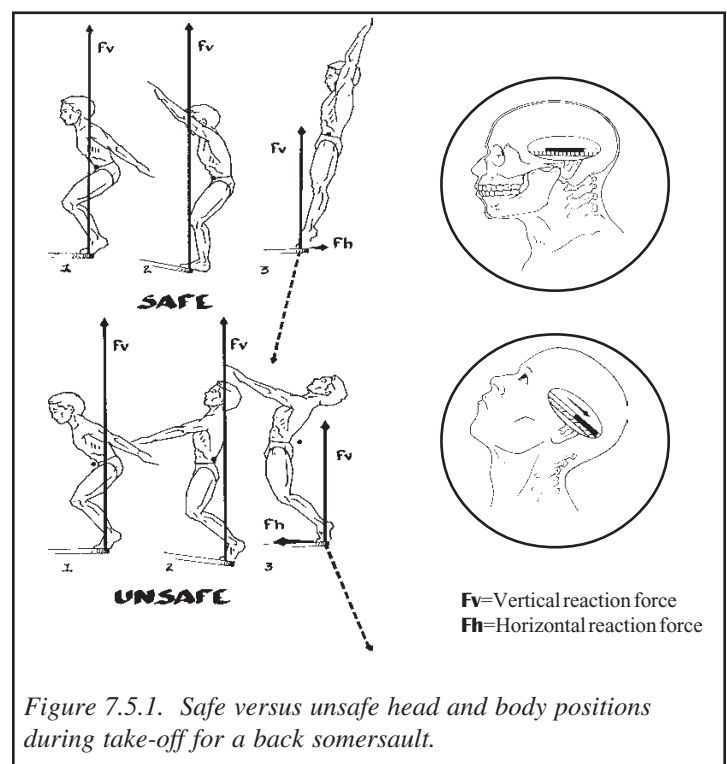

Figure 7.5.1. Safe versus unsafe head and body positions during take-off for a back somersault.

## Head orientation in flight

Just as a bird turning in flight maintains head orientation to the vertical, some divers, notably Louganis, have been observed to adjust the head position forward or “nod” while spotting the water during a back or reverse multiple somersaulting dive. This “nod” which accompanies the spot on each rotation apparently serves the purpose of reorienting the head to the vertical. Since the vestibular system does not provide information about the speed or direction of head movements of constant velocity (Shupert, Lindblad, & Leibowitz, 1983), the nodding head may provide the kind of movement input (i.e. head acceleration and abrupt change of head direction), that vestibular receptors more readily sense.

## Head position at comeout

The head position at comeout, especially in the “blind” back and reverse somersaulting dives, also affects orientation. Better spatial orientation performance may result with the head forward, as compared to the head back (Brown, 1961). The leg-first kick out provides the opportunity for divers to keep their head oriented toward vertical as long as possible, as well as affording sufficient time to focus on the appropriate spot before and after the kick.

## INTEGRATION OF SPOTTING AND FEELING

Feeling tells a diver that it is time to open up when performing a somersaulting dive. Feeling and spotting are not separate. A diver may learn to feel where he/she is in the air by learning to spot, and likewise may learn to spot by feeling where he/she is. When the diver sees the “spot” on the water or board come around on a single somersault, it reinforces the feeling of having completed one rotation and continuing on to one half rotation more.

A talented beginning diver may have a natural feel for his/her dives, yet not spot at all. Spotting provides verification that the diver is properly oriented. All divers should strive to learn to spot concurrently as new skills are acquired. The vestibular and somatosensory receptors that provide feeling and the visual cues combine to monitor spatial orientation. It is, therefore, important to emphasize both feeling and spotting together, especially in the beginning stages of learning new skills. Learning new skills without using spotting techniques may cause disorientation when visual cuing is attempted later on with the same skill. Divers should make every effort to feel and to spot with proper head orientation on every dive.

## Disorientation

Ordinarily, the inner ear, vision and other sensory cues provide spatial orientation. But the speed of rotation encountered during a dive (especially the more difficult dives) can provide misleading information to the diver. Also, not all sensory receptors adapt to a stimulus at the same rate. The diver may get lost on a dive. When this happens the diver seems to freeze in flight, and cannot find the water on entry. This condition which also afflicts pilots, has been described by

Stuller (1987) as a “perceptual straightjacket.” The reason for “getting lost” in a dive is not so much due to a failure of these sensory receptors as it is a “conflict” in the integration of sensory information (i.e. vision or somatosensory conflict with vestibular) (Debu and Woollacott, 1988). Conflicting information in the integration of sensory receptors explains the confusion the diver experiences in the learning process while reacting, for instance, to the increased acceleration forces experienced throughout a complete progression such as 203, 205, 207. Consequently, it is important that divers train to integrate more fully the visual, vestibular and proprioceptive receptors to insure more accurate feedback, and to enhance safety on every dive.

## Repetition

**Essentially, repetition of diving skills allows the diver to master the basic elements of the skill resulting in a more automatic motor program.** Exposure to disruptive stimuli is best filtered out through repetition, as divers become better practiced at suppressing disruptive visual and/or vestibular stimuli (Shupert, Lindblad, & Leibowitz, 1983). Divers should practice to eliminate the wrong moves and reinforce the right ones.

**Safety spotting in the overhead belts enhance the development of sensory integration, and thus body awareness and spatial orientation.** Just as seat belts in spacecraft provide spatial orientation cues for the astronaut (Campbell, 1967), so too in diving the safety belt (or even the manual spotter’s firm grip on the diver) provides the diver with spatial orientation cues which enhance the diver’s safety. Skill repetition in the overhead spotting belts develops and increases the diver’s proficiency and consistency.

## SPATIAL ORIENTATION AND BODY AWARENESS PERFORMANCE MARKERS

It is important for coaches to resist the urge to move the beginning diver on to harder dives too fast. Divers need time to learn to integrate their sensory systems’ input over many trials and under a variety of conditions. Here are some basic guidelines to help evaluate the diver’s body awareness and spatial orientation, which is a direct indicator of his/her readiness to move to more difficult dives or skills in the progression. The diver should demonstrate:

- Mastery of the basic dives before moving on to more complex diving skills.
- That all the body segments are in appropriate alignment, especially at take-off and entry when the body receives maximal force. Avoid exaggerated lower back arch.
- The appropriate body shape to move into and out of the basic positions safely and efficiently, when performing the core skills (line-ups, basic dives and somersaults) and lead-ups. The hollow or arch curved shapes should be distributed over as many body segments as possible.

•That the body position at take-off is aligned properly and in rhythm (tempo) with the board. In addition, the diver should duplicate about the same duration on the board during depression and recoil on multiple somersaults as achieved on the basic dive in each group (Miller & Munro, 1985).

•That the trajectory (flight in the air) is high and a reasonably safe distance from the board or platform before moving on to more complex skills in the progression.

•Awareness when he/she is not a safe distance (too close, too far out or off to the side of the board) and appropriate reactive responses.

**•The ability to make the appropriate distance correction on the next attempt.**

•The ability to feel the somersault and spot the board (or water) appropriately on the lead-up, consistently verifying that he/she sees the spot for each direction of somersault, before moving on to more complex skills in the progression.

•That the line-up is nearly vertical and the body rigid (arms tight against the ears, abdominal muscles tight, legs and toes stretched).

•A comfortable and relaxed attitude regarding the performance of the dive.

## REFERENCES

- Botkin M (1985) Gymnasts aid NASA in research of space-age problem. *USA Gymnastics*, 14 (4): 16-21.
- Brown JL (1961) Orientation to the vertical during water immersion. *Aerospace Medicine*, 32: 209-217.
- Campbell PA (1967) What has space taught us about disorientation. *Lectures in Aerospace medicine*, 6: 139-149.
- Debu B, Woollacott M (1988) Effects of gymnastics training on postural responses to stance perturbations. *Journal of Motor Behavior*, 20: 273-300.
- Dion D (1985) Prediction de la performance de l'athlete d'elite en plongeon par l'entremise de parametres anthropometriques et biomecaniques. Unpublished master's thesis, Laval University, Canada.
- Dix M, Hood J (1969) Observations upon the nervous mechanisms of vestibular habituation. *Acta Otolaryngological*, 61: 310-318.
- George GS (1980) *Biomechanics of Women's Gymnastics*. Englewood Cliffs, N.J: Prentice Hall, Inc.
- Gilmore KL (1990) Developing body awareness. In George GS (ed): *USGF Gymnastics Safety Manual*. Indianapolis, IN: USGF Publications, pp. 79-81
- Graybiel A, Kellogg RS (1967) Inversion illusion in parabolic flight: Its probable dependence on otolith function. *Aerospace Medicine*, 38: 1099-1102.
- Gruber FW (1982) The body alignment of classical ballet applied to springboard diving. In *Proceedings of Mission Bay Dive Clinic*, 1988.
- McCormick JH (1971) Relationship between position sense and beginning diving ability. Unpublished doctoral dissertation, Indiana University.
- Miller DI, Munro CF (1985) Greg Louganis' springboard takeoff: II. Linear and angular momentum considerations. *International Journal of Sport Biomechanics*, 1: 81-82.
- Pruett DM (1981) Ballet for divers. *Journal of Physical Education, Recreation, and Dance*, May: 35-37.
- Roth S (1985) Teaching body awareness. In George GS (ed.): *USGF Gymnastics Safety Manual*. Indianapolis, IN: The USGF Publications Department, pp. 81-82.
- Sands W (1989) Orientation in Space: Somersaulting and twisting. A grant from the U. S. Diving Foundation.
- Shumway-Cook A, Woollacott, MH (1985) The growth of stability: postural control from a developmental perspective. *Journal of Motor Behavior*, 17: 131-147.
- Shupert CL, Lindblad IM. and Leibowitz HW (1983) Visual testing for competitive diving: a two visual systems approach. In Golden D (ed.): *Proceedings of the United States Diving Sports Science Seminar*, Indianapolis, IN: U.S. Diving, pp. 99-115.
- Stuller J (1987) High Gs, High Risk. *Air and Space*. October/November: pp. 68-73.
- Whitlock S (1998) Body awareness and landings. In *USA Gymnastics Safety Handbook*, Indianapolis, IN: USA Gymnastics Publications, pp. 44-46.
- Woollacott M, Debu B, Mowatt M (1987) Neuromuscular control of posture in the infant and child. *Journal of Motor Behavior*, 19: 167-186.





## CHAPTER VIII

# KNOW DIVER'S SKILLS AND LIMITATIONS

### CHAPTER COMPETENCIES

**Upon completion of this chapter, coaches should be able to:**

- Recognize the physical risks in diving and how injuries may be controlled or minimized and the importance of reporting all symptoms immediately.
- Recognize and respond to symptoms of injuries that may occur in diving.
- Follow guidelines and instructions provided by a NATA certified athletic trainer, team physician and /or other qualified sport medicine professional in implementation of procedures for returning divers to practice/competition following injury or illness.
- Allow divers time to fully recover from injury before returning to practice.
- Maintain appropriate medical records for each diver, including medical information or physical screening and evaluation forms and treatment consent forms and have them available during all practices and competitions.
- Keep a record of communications with health-care providers concerning treatment of injured divers.
- Know and apply the rules and policies related to the safety and welfare of athletes during practice and competition.
- Assess the capabilities of divers based on age, maturity, size, skill level and experience.
- Assess athlete success in learning skills relative to their physical limits.
- Be able to use conditioning drills and activities consistent with the demands of diving.
- Consult with a NATA certified athletic trainer or physician, when appropriate, for assistance in understanding the physical needs of divers.
- Consider changing coaching techniques when a trainer or physician brings the need to do so to the coaches attention.
- Refer a diver to a NATA certified athletic trainer, team physician or other qualified provider upon sustaining an injury which requires more than minor first aid care; and check that the diver does not return to activity without clearance from such providers.
- Know and be able to teach activities that develop and maintain the basic level of conditioning needed for diving.
- Emphasize lifelong activity available in masters diving and enjoyment of physical activity as goals of participation in competitive diving.
- Know the most common preexisting conditions of divers and how to identify those divers suffering from these conditions, the circumstances in which these conditions put the diver at risk, how to modify the activity to effectively reduce that risk, how to recognize symptoms indicating that the condition is causing the diver to suffer activity related injury illness; and how to appropriately respond to such indications.
- Know the components of physical fitness and the appropriate levels of each in relation to age and demands of diving.
- Recognize that each diver is an individual with unique needs and treat each accordingly.
- Know the five essentials of conditioning: Warm up/cool down, overload, progression, specificity and reversibility and implement them according to the developmental level of the diver.
- Know how anaerobic energy is produced and relate this energy system to the demands of diving.
- Know how muscular system converts energy and how they respond to training.
- Know the role played by the musculoskeletal system in skill development and injury control.
- Understand muscular strength, power endurance and flexibility; know how each is required of divers; implement training programs that develop elements based on the developmental maturity of the diver.
- Know the components of the physiological systems involved in athletic conditioning.
- Know how warm-up and conditioning decisions influence the risk of injury to divers.

# Part 1. Orthopedic Care

by Benjamin D. Rubin, M.D.

## MECHANISMS OF INJURY

Orthopedic injuries occur in divers as in other athletes when the mechanical stresses on the body exceed the physiologic tolerance of the tissues being traumatized. This can occur in one of two ways:

1. A one time excessive force or **direct trauma**, such as a fracture or dislocation (acute injury).
2. **Repetitive microtrauma**, also known as an **overuse syndrome** (chronic injury).

The latter occurs in high performance athletes as a result of the intensity and repetition necessary in practice, as well as in poorly conditioned athletes who are not prepared for participation in their sport. Thus, appropriate conditioning including flexibility, strength, power and endurance training are the most important factors in prevention of overuse syndromes.

## SPECIFIC ORTHOPEDIC INJURIES

As noted above, injuries occur either as a result of a one time excessive force or as a result of overuse. The specific mechanical demands of diving lead to a unique pattern of injuries. The most common injuries that are observed in divers are listed by anatomical area.

### Cervical spine

Injuries to the cervical spine generally involve the muscles and tendons. These are classified as strains. (A sprain involves ligaments). Cervical strains and sprains are more common in platform divers. However, due to the protection afforded by the arms during entry, they are less frequent than would be expected. On occasion, a severe spasm will result from the trauma and it is necessary to limit training to dry land apparatus or completely to restrict training because of the stress on the neck musculature. As with other injuries, if performance is compromised by pain, then restriction of activity is necessary. On occasion, with a marked rotational or flexion stress to the neck, the nerves (brachial plexus) that go to the shoulder and arm can be stretched. Any injury to the neck, or, for that matter, to the lower back, that causes any loss of muscle function or sensation should be evaluated immediately by a physician.

### Lumbar spine

**Lower back injuries in divers are frequently associated with arching when pressing on the springboard,**

**hyperflexion during flight, “saving” with the legs and/or poor entry. The repetitive flexion (piking) and hyperextension (arching) during diving, especially during entry, are the main causative factors in chronic low back problems.** If low back pain does not respond to a period of rest, then orthopedic evaluation including X-rays is appropriate.

**Spondylolysis, which is thought to be a stress fracture of the spine is more common in divers than in other athletes;** however, it is not as common as it is in gymnasts. In the case of a stress fracture, it is possible that the X-rays will be normal, and it may be necessary to repeat the X-rays three weeks after the initial injury. A bone scan, CAT scan or MRI may be necessary in order to document the stress fracture. These fractures frequently heal without difficulty if treated appropriately, and upon return to diving, a back brace or a corset may be used for protection for a short period. An untreated spondylolytic defect may progress to spondylolisthesis in which one vertebra slips forward upon another vertebra. This can become disabling.

**Lower back strains are more commonly seen and frequently respond to rest and physical therapy.** Interspinous ligamentitis has been observed in a number of divers, and this responds well to physical therapy and/or cortisone injection. On occasion a diver may sustain a disc herniation which requires physical therapy and/or an epidural cortisone injection. Surgery is rarely necessary.

### Shoulder

**The shoulder laxity required for a diver to complete the mechanical demands upon the upper body may be a precipitating factor in many of the shoulder injuries that are observed. Most injuries appear to be related to repetitive overhead use of the arms and to the use of the arms to save short dives.** By far the most common shoulder problem seen in divers is multidirectional instability with secondary traction tendinitis involving the supraspinatus and biceps tendons. These symptoms present primarily as an impingement syndrome.

**It is extremely important that the diver has appropriate strength in the rotator cuff and scapular stabilizing musculature in order to avoid serious chronic injury to the shoulder.** If acute dislocation of the shoulder is observed, immediate relocation by a physician or certified trainer must be carried out. Other factors that affect the incidence of shoulder injuries are growth, development and genetics. A number of divers have been diagnosed with congenital structural defects which affect joint function. Frequently, rest periods are necessary as well as formal physical therapy programs in order to allow a diver to return to diving. In some cases, surgery is necessary to correct symptomatic pathology if a diver cannot perform despite treatment.

## Elbow

The most common injury observed in the elbow region is triceps tendonitis or triceps strain. This muscle is involved with holding the elbow in an extended position upon entry. Inflammatory conditions are frequently observed from repetitive stress to this area, especially when the elbow is not completely locked out. These injuries are more common in age group divers than in senior divers. Platform divers also have a higher incidence of elbow injuries than springboard divers.

## Wrist and hand

The direct trauma to the wrist as a result of the repetitive impact of the flat hand entry technique causes forced dorsiflexion of the wrist, especially in platform divers. This is aggravated by the forceful dorsiflexion used in pushing on the deck when getting out of the pool as well as when doing armstand dives. The most common wrist problems seen in divers are subtle instabilities of the carpal bones, especially the lunate. Dorsal impaction syndrome as well as stress fractures and cartilaginous injuries in the wrist joint have been observed. Fractures do occur, although these are not very common. Most wrist problems are chronic but, with appropriate strengthening exercises and bracing, can be minimized or avoided. Manipulation is sometimes necessary.

Also common in platform divers are injuries to the carpal-metacarpal and metacarpal-phalangeal joints of the thumb, frequently as a result of missing a grab for the hand before entry. This usually responds well either to taping, or to use of a hexcelite splint which is seen in Figure 8.1.1. Tendinitis in the wrist and thumb has also been observed, and these respond to the same treatment as well as to anti-inflammatory medication.

Injuries to the hand as a result of striking the board include fractures and contusions. In young divers who do not have the strength to keep their elbows extended on entry, contusion (a bruise) caused by striking the back of the hand on the head, is not uncommon. Various protective devices have been designed to prevent this injury during training.

## Lower extremities

Injuries to the lower extremities in divers are uncommon. Fractures of the foot from hitting the board do occur, however, they are less common than fractures of the hands. Stress fractures of the tibia and posterior tibial tendinitis (shin splints) have been observed as a result of constant use of poorly mounted non-flexible springboards or excessive bouncing on a flexible springboard. Frequent imbalances of muscle groups, as well as inadequate stretching of the posterior tibial muscle-tendon unit, have been considered causative. It is necessary to bear in mind that although a diver may be flexible, excessive flexibility is necessary in order to meet the demands of diving.

In the case of tendinitis, the symptoms usually occur in the middle and/or lower third of the front inner side of the shin.

This area is tender when examined and there is pain with passive plantar flexion (toe point) and eversion (toe out) of the ankle. These problems are frequently seen in divers who jog as part of their conditioning program. When lower extremity malalignment is causative, this frequently responds well to customized orthotic devices being placed in the running shoes.

## Abrasions

Most soft tissue injuries that are seen in divers are abrasions, either from hitting the board or scraping against the side or the deck of the pool. In such cases, the coach should control external bleeding, ice the affected area and direct the diver to appropriate medical care if deemed necessary. Frequently, first-aid treatment is sufficient and evaluation by trained medical personnel may not be necessary.

## MINIMIZE THE MAGNITUDE OF INJURIES

### Initial management of athletic injury

When an injury occurs, it is imperative that the affected area be treated with “P.R.I.C.E.” - **protect, rest, ice, compression and elevation**. If a fracture or dislocation is suspected, the involved extremity should be immobilized or splinted to prevent further injury while the diver is being transported. The diver should be immediately transported to a medical care facility where appropriate evaluation can be carried out by qualified medical personnel, and X-rays taken if necessary. In general, ice should be used at 20 to 30 minute intervals over the first 48-72 hours following an acute injury, and usually for as long as the injured area is swollen. Heat should not be applied while swelling is present, as it increases the blood flow to the area and thus increases the degree of swelling.

### Return to diving

Frequently, it is difficult for a medically untrained individual to make a decision about when it is time to allow a diver to return to diving. Therefore, a sports medicine specialist (physician or NATA certified trainer) may need to be consulted. The following general guidelines are used to determine performer readiness to return to activities. **The diver should: (1) exhibit a pain free normal range of motion in the injured area, and (2) be able to perform training activities without obvious impairment to the affected body part.**

If a diver is changing his or her mechanics, such as not swinging his arms through, not lining up, limping or favoring an extremity (indicating compensation for an injury), participation should not be allowed. Frequently, overcompensation for an injury makes a diver more vulnerable in other anatomical areas. If there is any question about a diver's ability to return to diving, it is better to err on the side of caution, to limit participation and consult with trained professionals (see page 22) rather than to make a decision for which one is unqualified.

## INJURY CONTROL

### Preventative taping and bracing

**Taping and bracing of injured areas are effective ways of allowing divers an earlier return to diving following an injury. It is also helpful in preventing re-injury. This has been especially true with hyperextension injuries of the thumb and wrist.**

Figure 8.1.1 illustrates a custom hexcelite thumb brace that has been used effectively in the treatment of injuries to the thumb (metacarpal-phalangeal) and wrist (carpal-metacarpal) joints of many divers. This brace is easily fabricated and fitted during an office visit. Adjustments can easily be made when necessary. Wrist pads, which can be made by the diver or the coach, have been effective in preventing hyperextension injuries of the wrist. These have been particularly useful in platform divers. The most important aspect of the use of this "dorsal block pad" is the placement of the pad in the right anatomical location with respect to the wrist joint.

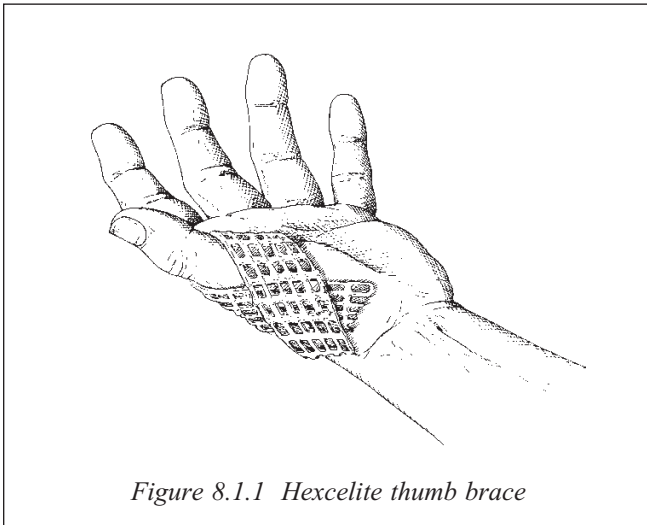

*Figure 8.1.1 Hexcelite thumb brace*

### Skill progression and body alignment

Developmental divers should be encouraged to master the core skills first and progress gradually to the more difficult dives. Emphasis on development in the younger diver should be placed on body alignment, coordination control, strength, power and flexibility. When the body is properly aligned at take-off, energy transfer from the board to the diver can be more fully maximized in a biomechanically efficient manner to increase the height of the dive, while at the same time risk of injury can be minimized. The assessment of proper body alignment for each individual is integral to safety in every skill progression.

### Rehabilitation and conditioning

Many of the problem areas that are seen in diving can be avoided by adequate pre-participation screening evaluations (see pp. 19-21) that are specifically directed to this sport with

concentration on areas that are frequently injured. Problem areas discovered during the pre-participation screening should be targeted as part of a rehabilitation program. These programs should be supervised by a NATA certified athletic trainer, team physician and/or other qualified sport medicine professionals.

Coaches need to be aware that athletes, even Olympic caliber athletes, tend to deny the importance of rehabilitation and conditioning. Rehabilitation and conditioning may not be perceived as being as much fun as performing the dives. If left unattended, these problem areas (tight hamstrings, tendinitis etc.) can compromise the athlete's ability to perform in the short term and may eventually shorten the athlete's career in the long term. If problem areas are not addressed, they may increase the likelihood of the athlete experiencing an injury, especially those injuries related to overuse. Furthermore, injuries can be minimized by appropriate conditioning in the form of flexibility and strengthening exercises. Since no one can do the rehabilitation/conditioning program for the diver, ultimately it is the diver's willingness to discipline him/herself to follow the conditioning program that determines the result. What the parent, coach, physician, trainer and administrator can do is structure the situation and use of time at every level to motivate the athlete to maintain constant vigilance with respect to the rehabilitation/conditioning program(s).

## REFERENCES

- Anderson SJ, Rubin BD (1996) Evaluation and treatment of injuries in competitive divers. In Buschbacher R, Braddom R (eds.): Sports Medicine and Rehabilitation: a sport-specific approach. Philadelphia: Hanley and Belfus, Inc. p. 111-122.
- Gater D, Rubin B (1988) Strength and conditioning programs for sports of the Olympic Games. National Strength & Conditioning Association Journal, 10 (4): 7-25.
- Newman A (1990) Medical responsibilities in gymnastics. In George GS (ed.): USGF gymnastics Safety Manual (2nd edition), Indianapolis: The USGF Publications Department, pp. 13-23.
- Rubin B (1983) Orthopaedic aspects of competitive diving. In Golden D (ed.): Proceedings of the U.S. Diving Sports Science Seminar. Indianapolis, IN: U.S. Diving Publications, pp. 65-78.
- Rubin BD, Anderson SJ (1996) Diving. In Caine DJ, Caine CG, Lindner KJ (eds.): Epidemiology of Sports Injuries, Champaign, IL: Human Kinetics, pp. 176-185.
- Rubin B, O'Brien R (1985) Preliminary results of an EMG analysis of the shoulder in diving. In Golden D (ed.): Proceedings of the U.S. Diving Sports Science Seminar. Indianapolis, IN: U.S. Diving Publications, pp. 73-77.

## Part 2. Physical Readiness

by Michael S. Brown, M.S.

Assessment of physical readiness is an injury control strategy. Assessment begins prior to the diver's training and continues throughout his/her participation. Pre-participation screening evaluations, consent waivers and release of liability forms, swimming competency assessment and skill, strength/power and flexibility assessments are recommended to help the coach evaluate the diver's physical skills and limitations. Warm-up, strength/power, and flexibility exercises are also essential to the physical preparedness of the diver.

### READINESS

Readiness is preparedness to perform a given task or activity. To a large extent, the competition rules set the standard for the demands placed on the diver. Based on experience, the contest rules regulate the number of dives and event height according to age group. The diving coach should understand how the rules of the diving contest provide for a gradual increase in number of dives and event height from young age group divers to seniors. For example, in FINA age group platform rules, 12-13 year olds (Group C) may compete on the 5-meter platform only; 14-15 year olds (Group B) may compete on 5- and 7.5 meters; and 16-18 year olds (Group A) may compete on 5-, 7.5- and 10-meter. All age groups compete on both 1-m and 3-meter springboards, however, the number of dives increases with age from six dives in Group C to eight in Group B and nine dives for girls and ten for boys in Group A. Senior males compete eleven dives on 1- and 3-meter and ten on platform. Senior women compete ten dives on 1- and 3-meter and nine on platform.

Contrariwise, the masters age group contest structure provides for a gradual decrease in the number of dives as the masters diver ages. On springboard, the number of dives decreases from eleven for men and ten for women in the 25-29 year old age group on springboard to four in the 80 + age groups. On platform the number of dives decreases from seven dives in the 25-29 year old age group to three in the 80 + age group (FINA Handbook & Addendum 1998-2000). In addition to the number of dives and event height, degree of difficulty is another contest requirement that also varies with age and skill. The coach should understand the gradual progression in competitive demands by age group and prepare the diver appropriately to meet them.

### SHARED RESPONSIBILITY

There are several people who share in the responsibility for the physical readiness and safety of participants in diving programs, besides the diver him/herself. The parents or guardians of the diver and the diver's physician also share in

this responsibility, but the diver's coach has the most responsibility (Malmberg, 1985). The coach guides the diver on an individual basis and is the most immediate observer and director of activities. Although other people also share in the responsibility, the coach should attempt to coordinate activities to make sure the administration of the diving club, the university/school, aquatic facilities and their respective sponsoring organizations and medical staff are all doing their part. The diving coach is responsible for teaching the physical skills of diving using proper mechanics and appropriate progressions to develop skill and condition the diver in a manner that will reduce the likelihood of injury.

### PRE-PARTICIPATION SCREENING EVALUATION

The coach should periodically require a preparticipation screening evaluation for all divers (see pp. 19-21) (Cantu & Micheli, 1991; Mueller & Ryan, 1991; American Academy of Pediatrics, 1992; Sawyer, 1992). Guidelines for evaluations may be set by state or local law or by an administrative body. To increase awareness of preparticipation physical exams, the National Youth Sports Safety Foundation, Inc. has prepared a fact sheet. Some facts about which coaches should be aware include the following: A routine physical exam is not considered to be adequate as a screening for sports participation (Thomas 1983). Coaches should be aware that most conditions that predispose young athletes to injury or death during sports activity participation are found in the medical history rather than the physical examination (Cantu & Micheli 1991; Sullivan & Grana, 1990; Blum, 1985). Even young athletes ages 6-10 years should have preparticipation screening evaluations. The prepubescent child may have clinical congenital abnormalities, such as heart defects, which have not previously been diagnosed (Avella & DeGeronimo, 1990). A licensed physician screens the divers. The physician's signature on the preparticipation screening form validates the evaluation.

Preparticipation screening evaluation forms should list any physical limitations of the diver. These forms should be kept by the coach in an easily accessible permanent file. The coach reviews the screening forms. He/she discusses any physical limitations with both the would-be diver as well as his/her parent/guardian. All parties need to understand the ramifications of any limitation. Prior and current medical conditions detected in the preparticipation screening forms should be taken into consideration when preparing a workout schedule for the diver. Besides physical problems, other psychological and nutritional problems should also be taken into consideration such as eating disorders (bulimia, anorexia nervosa), fears or any other personal problems that might affect the ability of the diver to concentrate and perform safely.

The preparticipation screening evaluation can be a meaningful injury control tool, however, in practice there are limitations related to its use that are, for the most part, not within the control of most coaches. In many cases, it is the parent who determines who will complete the screening evaluation for his/her child. Coaches and parents should be aware that most physicians do not have training in sports medicine. Experience shows that much of the information requested on the screening form may not even be completed by the physician. Physicians who actually do perform a thorough preparticipation screening evaluation as requested may charge hundreds of dollars for the exam (Major, McNeal & Sands, 1996). To more fully realize the potential of the presport screening tool, the National Youth Sports Safety Foundation recommends that physicians have additional training in sports medicine. The American College of Sports Medicine offers a Team Physician Course.

### **Eyes/vision**

In general, sports *like diving* that do not involve a thrown or hit ball, a stick or close aggressive play have a very low incidence of eye injuries (Vinger, 1994). Coaches should be aware that potential damage to the eye may result if a diver in a safety belt has a congenital predisposition towards bleeding (Medical History p. 19-Question 9) and is tipped into excessive multiple somersaults which greatly exceed competitive diving somersaulting demands (Rabinovitch, McLean, Beck, & Brown, 1978).

Visual skills are important to the diver's safety and performance. The diver should have adequate eye muscle control which allows focus and pursuit of a target (board and water). Visual spotting is an important technique used in diving to help divers accurately identify their body position while somersaulting and orient the body to vertical for the entry. A diver who gets lost in airborne flight may have an ocular pursuit problem. Vision enhancement programs are now available to athletes (USOC Sports Mediscope, 1988).

Divers who wear glasses also need to wear safe lenses, frames and securing devices during dry land training. The National Youth Sports Safety Foundation's fact sheet on eye injuries recommends polycarbonate lenses for all children. In addition, sports frames should fully cover the eye area with contact at the bridge of the nose and both temples and contain safety bevels to prevent the lens from popping loose from the frame and in toward the eye. The benefits of wearing contact lenses for dry land training and actual diving activities should be discussed.

### **Disabilities and/or impaired function**

All responsible parties should be aware of the safety and performance implication of any existing physical disabilities and/or impaired function. This would include missing digits, limbs, kidneys, spleen, etc., or a congenital bleeding predisposition as well as hearing and vision impairments. The coach should be aware that postural defects, shoulder and other joint instability often go undetected on the preparticipation screening, as congenital problems are

especially difficult to recognize in children. The coach should therefore discuss any indications of congenital problems with the parents and suggest the diver be referred to a physician for evaluation and training modifications.

### **SWIMMING COMPETENCY ASSESSMENT**

Using a standard procedure that includes both the frequency and severity of accidental injuries as determined by the CPSC injury severity scale, drowning and near-drowning were calculated to account for 75% of the total risk of accidental injuries for spas, pools and related equipment (McCarthy & Robinson, 1985). Swimming skill is a prerequisite to learning to dive, therefore all participants in learn-to-dive programs should pass a swimming competency assessment. A suitable test for most circumstances is being able to swim unaided for 25 yards.

### **ENERGY PRODUCTION IN DIVING**

Diving motor skills require a very high intensity performed over an extremely short duration, using the phosphagen (ATP-PC) energy system (Gater & Rubin, 1988). The ATP-PC energy source appears to be depleted in approximately 6-10 seconds, and stores may be replenished in approximately 50-60 seconds (Kearney, 1987). ATP is replenished rather quickly but the ability to return a maximal effort takes longer. This delay is due in part to a clearance of lactic acid. Typically, divers rest between dives so that the nervous system can be made ready for another maximal effort. Strength/power fitness is characteristic of diving. Divers can most effectively increase their strength/power levels through a combination of strength/power training in the weight room and plyometrics. Divers are power athletes, and as such are encouraged to take approximately three full minutes (two minutes minimum, up to five minutes) between sets in the weight room to reduce any influence of fatigue.

### **FITNESS COMPONENTS**

Each diver entering the diving program brings with him/her a degree of fitness in the following components:

- Strength
- Power
- Flexibility
- Muscular Endurance
- Cardiorespiratory endurance
- Body Composition
- Skill

It is the coach's responsibility to develop in the diver a sport specific blend of these characteristics that is unique to the sport of diving. The development of the appropriate levels of fitness can greatly add to an individual's enjoyment of diving by enhancing the diver's ability to perform complex skills (Sands, 1990; Whitlock, 1998).

## Strength

Strength is any maximal force production (Sale & Norman; 1982). Strength is important in diving for holding a handstand on platform, holding specific muscles “tight” against gravity upon entering the water, and holding tuck and pike positions while somersaulting.

## Power

Power is required in diving when a muscular force must be exerted quickly. Power is defined as force x distance per unit time, which includes the component of movement or speed (Gater & Rubin, 1988). The rate of application of muscular force varies for springboard and platform take-offs.

### Springboard

On springboard there are two examples of strength/power augmenting performance: (1) stronger/more powerful legs may increase the duration of the take-off, thereby increasing the vertical jump and (2) stronger/more powerful arms may be swung quicker and straighter. Strength/power is basically the capacity for exerting vertical force. For example, sufficient height has been determined to be the critical biomechanical element for safe board clearance. Research has indicated that elite divers are not simply passively “riding the board” but rather are actively pushing downward against the board to aid its depression. The legs are responsible for about 75% of the center of gravity’s acceleration with 50 of the 75% resulting from the legs accelerating the trunk forward (Miller, Jones, Pizzimenti, 1988). These research findings accentuate the importance of leg strength/power to diving safety (Miller, 1983).

Squatting movements are trained without emphasis on speed at first but with great attention to detail, beginning with no or light resistance. Form and strength are developed before shifting training emphasis from strength to power. Every movement in the direction of gravity is controlled by an eccentric tension. Squatting is controlled by leg extensors, not flexors. In a concentric tension, the internal force produced by the muscle exceeds the external force of the resistance and the muscle shortens, producing movement. In an eccentric tension the muscle lengthens while continuing to maintain tension. Leg strength/power is represented by both eccentric (lengthening quadriceps, such as landing on the board out of a hurdle) and concentric (shortening quadriceps, such as when exploding into a vertical jump take-off) tensions of the knee, hip and ankle extensors during take-off.

A stronger more powerful body becomes less prone to injury due to an increased ability to withstand physical stress. Joint stability is directly related to the strength/power and balance of the muscles that cross the joint.

### Platform

Although the movement patterns may be similar, platform take-off durations are much quicker than springboard. Since the take-off surface is rigid, platform diving presents a conditioning challenge to the elastic (connective tissue) components of muscle.

## Flexibility

Flexibility is the range of motion (ROM) through which the joints of the body can move within the limits of pain. Active flexibility in diving enables the diver to move a body segment against gravity and/or the opposing stretch of the antagonist muscles. Diving requires wide ranges of joint motion for both function and aesthetics. The functions of take-off require plantar flexion and dorsiflexion in the ankle, flexion and extension in knees and hip for squats and jumps, shoulder circumduction in armswings, and flexion and extension of the spine to initiate somersaults. In general, the more somersaults initiated, the greater the degree of the flexion or extension of the spine required. A functional hollow shape to create a rip entry requires shoulder girdle flexibility along the long axis with the arms overhead. Aesthetics require an elongated rigid body with knees locked and ankles and feet plantar flexed during entry.

The objective of a stretching program is to achieve a desired muscle length and joint capsule flexibility, so that the diver’s optimum strength/power may be applied throughout the full range of motion. This should enhance performance as well as safe participation in diving (Mangine, 1982). **STRETCHING MUST BE DONE GRADUALLY.** For injury control, the diver should demonstrate flexibility at the extremes of the range used during the competitive activity (Mangine, 1982).

In competitive diving there are recognizable injuries to specific body areas, such as the lower back (Mangine, 1981). Prevention is the key to the elimination of back pain. A flexibility program must take into account mechanical factors as well as muscular ones. Thus, the program must be oriented toward improving postural conditions as well as muscle function (Mangine, 1982). For example, in the case of lower back pain, both lower extremity and trunk mechanics are involved. The stretching routine must not only take into account trunk bending and extending but hamstring (posterior thigh), hip flexors (anterior thigh) and gastrocnemius (posterior calf) (Mangine, 1981). Stretching and postural routines should be performed in all planes of movement.

No two divers possess the same flexibility. In fact, flexibility is also “**joint specific**” within each individual. For example, just because a diver can demonstrate a wide range of motion in one shoulder joint does not necessarily insure that the other shoulder joint is equally flexible! A flexible lower back does not guarantee that the diver also possesses a flexible upper back!

## Muscular Endurance

Muscle/anaerobic endurance is a fitness characteristic that involves work output of relatively high levels for activity of greater than 10-15 seconds but less than two minutes (Sands, 1990). Muscular endurance will also be developed to a certain degree through trampoline and dry land work where little rest is taken, and in the early part of the general preparation phase of a periodized weight training program.

## Cardiorespiratory endurance

Cardiorespiratory/aerobic endurance refers to low work intensity levels for activity lasting longer than two minutes (Sands, 1984, 1990). Coaches should be aware that divers who train aerobically for weight control do so at the expense of a possible decrease in their power output (i.e. vertical jump) (Gater & Rubin, 1988).

## Body composition

Body composition is the ratio of lean body mass to nonessential fat body mass. Lean body mass includes tissues of muscle, bone, viscera, connective tissue, blood, nervous tissue and essential fat. The fat body mass refers to nonessential fat deposits. Divers need to have a high strength to weight ratio in order to achieve powerful take-offs and control the body in the air and on the entry. Divers with excessive nonessential fat or who have disordered eating may be more susceptible to injury and should be advised to discuss proper diet and safe weight control methods with a registered dietitian. A medical or sport psychologist with a background in eating disorders may also be an appropriate resource in certain situations.

## Skill

Divers learn skills in progression from jumps to multiple somersaults and twists in five dive groups on springboard and six on platform. There are many core skills and skill parts that are similar among dive groups. These skills, such as hand grabbing, entry alignment, leg first comeouts with mid-line bent elbow and lateral arm paths, squatting, jumping and holding an armstand should be mastered first. In addition, divers learn motor fitness on these skills that include kinesthetics (feeling), spatial orientation and visual spotting.

## ASSESSMENTS

### Strength/power and Flexibility

**Periodic tests or reviews of the diver's strength/power, and flexibility are recommended to assess the diver's physical readiness.** Since flexibility is joint specific, screenings, evaluations and subsequent flexibility programs should emphasize training prescriptions that are highly individualized so that each diver can achieve the proper "balance" in joint range of motion for the entire body. The coach should be responsible for supervising and evaluating the relative effectiveness of the flexibility program. Periodic evaluation of each diver's progress is advisable. Keep in mind that certain individuals are inherently more flexible than others (Malmberg, 1985). Norms for divers by age are included in the U.S. Diving Future Champions and Champions Challenge test kits (O'Brien, 1993). Coaches should periodically test and retest a diver's progress in resistance training and flexibility programs on the diving specific tests.

## Skill

**In general, the best indicator of readiness to perform is a diver's ability to perform a more basic lead-up or**

**progression skill.** This lead-up may be a dry land or gymnastic skill or an actual diving skill progression. Physical readiness assessments should focus on evaluating the relevant lead-up movements and core skills specific to the activity. Coaches are encouraged to evaluate the diver's progress in attainment of skill proficiency (see p. 34).

## WARM-UP

An important part of any diving session is the warm-up. Warming-up is essential to the physical preparedness of the diver. Vosler (1985) explains that the warm-up helps protect against injury of muscle, joint and connective tissues (tendons, ligaments). This protection is especially important in diving, which is characterized by explosive vertical jumps and "ripped" water entries.

## Increased Body Temperatures

**The warm-up should help the diver maintain adequate body temperature throughout the diving workout.** Divers compete in a variety of environmental conditions. Indoor facilities during the cold winter months may be drafty. Divers are required to withstand the elements in outdoor facilities. Exposure to extreme cold (as well as overheating of muscles) can lead to decreased function. Care should be taken during the diving workout to maintain appropriate body temperature during an extended period of time. Drying off between dives, continuing warm-up movements, and external warming equipment such as heat lamps, warm showers or a hot tub have been found to be helpful in maintaining an elevated body temperature during workouts.

Generally, the body core temperature has been raised sufficiently to increase muscular efficiency when the athlete begins to perspire (de Vries, 1966; Unitas & Dintiman, 1979; Sands, 1990).

Generally, a good warm-up prepares the body for activity by:

- increasing body and muscle temperatures,
  - facilitating enzyme activity, which raises the muscle's metabolism,
  - increasing the amount of blood and oxygen reaching the skeletal muscles,
  - improving the contraction and relaxation times of skeletal muscle.
- moderately increasing muscle temperature to increase muscle strength and joint flexibility, which will enable the diver to perform more effectively.**

## SAMPLE WARMUP

Dance, running in place, calisthenics, jumping, and skipping, combined with stretches of the arms, trunk, legs, and neck are typical exercises that can provide a thorough warm-up to diving activities. The following exercises are typical of a basic warm-up in a competitive diving program:

1. Begin with 5 minutes of running, skipping, jumping jacks or hopping in place or around an unobstructed area. It is recommended to do this type of work on a mat or a soft dry surface, such as grass, wearing running shoes.

2. Standing with feet apart and arms extended, bend at the waist forwards, sideways, right and left, then slowly circle trunk several times to the left and right.

3. Lie supine. Lift one knee toward the chest, then the other and hold. Lift the head also for a stronger stretch. Pull into a tight tuck position, grabbing the shins and rock back and forth.

4. Standing with arms extended, slowly swing arms in small circles, then increase to wide circles in both directions, taking time to thoroughly warm-up the entire shoulder area. Perform several circles to the front of the body and overhead. Shake arms and shoulders to relax the muscles.

5. Sitting upright on the floor, legs together in front, knees straight, stretch forward, slowly reach for pointed toes.

6. In an upright sitting position, with wide straddled legs, toes pointed, bend forward slowly stretching the chest towards the floor, reach and bend toward the right leg, then the left leg.

7. Lie on the back, bring both legs slowly backward overhead toward the floor, while maintaining thoracic spine contact with it. Do not roll back on the neck.

8. Lie extended on the back, then assume a slightly hollowed total body shape. Rock back and forth on the back several times.

9. Lying on the stomach, raise the head up, arms laterally, and legs upward to an arched position several times and hold an arch for several seconds. Spread the arch out over the whole trunk rather than solely in the lower back.

10. Lie extended on the back with arms overhead, contract into a tuck position, balancing on the seat; extend the knees. Straighten the elbows moving the hands in the same direction as the feet. Leave the hands on the thighs. Look at the toes. Using a midline bent elbow arm path, return to the supine starting position with arms overhead. Repeat “tuck kick-out.”

11. Standing with the arms extended, bend one knee and bring a heel to the buttocks. Hold the foot with the same hand. Keep the knees close together and squeeze the buttocks.

12. Sitting on the floor, extend and flex the wrists, using the opposite hand for assistance. Clasp hands together and interlock fingers, rotate wrists in a circular or figure-eight fashion.

13. While standing, grasp hands overhead in the entry position, then spread arms quickly, pulling them down in front. Repeat this “swim entry” action several times.

14. When facilities have sufficient space and appropriate matting is available, elementary gymnastics movements such as rolls, extensions, cartwheels and handstands may be used as warm-up exercises for diving activity. Any somersaulting

activity should only be done under the supervision of the coach and after the physical warm-up.

## WARM-UP GUIDELINES

The warm-up session may be a routine procedure designed by the coach, or it may be adapted to the workout that will follow. It should take into account the diver's specific needs as well as his/her strengths and weaknesses. The warm-up program should be progressive. A well balanced warm-up should combine vigorous gross motor movements as well as light stretching exercises through a variety of motions in specific joints. The warm-up should:

(1) last from five to ten minutes,

(2) be mildly vigorous (enough that the athletes are a bit out of breath when they talk),

(3) avoid extreme ranges of motion,

(4) be sufficiently simple that skill does not play a major role in the performance of the warm-up activities,

(5) include all the major muscle groups of the body, direction of limb motions and major body movements,

(6) and conclude with stretching exercises specific for the skills being performed during subsequent training sessions, and with easy skill rehearsal. Stretching exercises designed to enhance flexibility should be reserved for later in training following the warm-up and/or at the end of any diving, trampoline, dry land or resistance training workout (Bompa, 1983; Sands, 1990).

## BASIC RESISTANCE TRAINING

It is recommended that divers follow a regular resistance training program. This program should be based upon a diver's age, physical development and a periodic assessment of the diver's strengths and weaknesses. Safe application of a resistance program requires instruction by a qualified person. Performing resistance exercises incorrectly minimizes effectiveness and can actually cause and/or contribute to injury. Coaches should be aware that a “rounded back” position is dangerous in lifting weights because the compression load acts on the anterior part of the intervertebral disks while the extension load acts on the posterior part, thus increasing the pressure on the disk (Zatsiorsky, 1995).

A resistance training program should provide for a “balance” in one's strength such that the diver is not strong in certain muscle groups and very weak in others. Since diving requires control, balance and strength/power in a wide variety of movements, achieving the proper balance in the resistance training program helps the individual to participate more efficiently and more safely (Malmberg, 1985). Divers must be physically prepared to withstand the impact of water entry unique to this sport. Rubber tubing exercises have been especially useful in diving training programs for shoulder/rotator cuff injury control and rehabilitation.

## TRAINING PRINCIPLES

The effectiveness of a resistance training program depends greatly on consistent participation in a planned program. Increases in strength/power will not usually occur if exercises are applied sporadically. The coach should follow a periodized program which is appropriate for his/her divers and their competitive schedule to maximize the strength/power benefits from the program. Coaches regulate exercise overload in progressive stages to condition divers in a manner specific to the energy production and muscular strength, power and flexibility demands of the sport. Manipulating the basic training principles, such as volume, intensity, variation, and specificity will help to reduce overtraining and monotony, and bring performance to a peak at the right time (Stone & O'Bryant, 1987). Setting aside a structured time, preferably after diving activities, can help provide for program consistency. Maintenance training between seasons is advisable as fitness gains are reversible.

**Periodization** is a process of dividing the annual plan into smaller phases of training in order to allow a program to be set into more manageable segments and to provide a correct peaking for the main competitions of the year.

## YOUTH RESISTANCE TRAINING

Resistance training is now recognized as an important component of youth fitness programs, health promotion objectives, and injury control strategies. During supervised training programs the incidence of soft tissue injuries does not appear to be greater than in any other sport. There is some research that suggests a role in injury control as demonstrated by decreases in injury rate, injury severity or joint pain (Micheli, 1998; Hejns, Rosenberg & Bufurusis, 1982). Improved connective tissue strength in resistance trained individuals may be a factor in decreased injury rates (Kraemer, Deschenes & Fleck (1988). Trained fitness professionals must supervise every exercise session and must have a thorough understanding of youth resistance training and safety procedures. Different resistance training modalities have proven to be equally effective for children. The size of the exercise equipment should correspond to the size of the child. Although resistance training equipment is required for many exercises, body weight-resisted and partner-resisted exercises are viable alternatives. Push-ups, sit-ups, chin-ups, running, jumping, rope climbing, and handstands are exercises which are typical of a well rounded general conditioning program. Coaches working with entry level untrained young children should be aware that, depending on the child and the exercise, body weight may be too heavy. In those instances, coaches may have to find ways to reduce the resistance such as push ups from the knees.

The total exercise picture which includes free play as well as organized sports should be carefully considered. An important consideration in injury control is the coach's awareness of the variability in children of the same age in their ability to tolerate stress. Because of this interindividual variability in stress tolerance, each child must be treated as an individual and observed for signs of stress that would require a modification in frequency, volume, intensity, and progression

of training. Correctable risk factors such as muscle imbalances, inflexibility, poor physical condition should be identified so that coaches and clinicians can address each child's specific needs. In some instances it may be necessary for young athletes to reduce their sport involvement to allow time for preparatory conditioning. Coaching guidelines on youth resistance training are available through the NSCA (Faigenbaum et al., 1996) and FIMS (Golan et al., 1998). Recommendations may change as additional research becomes available.

## RESISTANCE TRAINING GUIDELINES

1. Resistance training programs should be supervised. If sessions are held prior to an actual diving workout, sufficient time should be allowed for recovery and workout demands adjusted accordingly. Resistance training sessions held after diving training help to avoid the tendency toward the development of undesirable technical habits as well as the possibility of injury due to muscular fatigue.
2. In general, if a child is ready for participation in sports, he or she is ready for some type of resistance training. Coaches must recognize the different maturation rates of children and be aware of the genetic predispositions for physical development. Although resistance training equipment is required for many exercises, body weight-resisted and partner-resisted exercises are viable alternatives.
3. For the older adolescent and adult, weight training should serve as a supplement to general body conditioning, although specific muscles may be targeted for development.
4. A "base" for weight training should be established by a period of general conditioning and light to moderate weights lifted with 8-12 repetitions. Each workout should begin with a general whole body warm-up (e.g., this may include jogging for approximately five minutes and stretching all the major muscle groups). A specific warm-up, consisting of a light to moderate warm-up set, should be done for each primary weight training exercise (Stone & O'Bryant, 1987). From a "base" the diver can progress by appropriately manipulating volume, intensity, variety, and specificity of exercises related to diving. Guard against "overtraining" as well as "undertraining."
5. Resistance training should progress from multi-jointed, structural or whole body movements involving large muscle groups before moving on to isolating individual muscles. Work on one muscle group should usually be accompanied by work on the opposing muscle group. This should prevent overdevelopment of one muscle group and unequal fatigue of opposing or supporting muscles involved
6. Resistance training exercises should, as much as possible, closely simulate diving skill objectives (specificity of training). For example, properly executed weighted jumping lunges are specific to the hurdle used in springboard diving. Medicine ball work can increase the power of the diver's armswing on the front/inward as well as back/reverse take-offs (Gater & Rubin, 1988). Standing front, back, reverse and inward somersaults on mats is a very specific way to incorporate plyometric work for divers who possess the adequate strength/power necessary to perform these skills (Gater & Rubin, 1988).
7. Resistance training should be executed with proper form and mechanics throughout the exercises. Poor training techniques could transfer into poor diving skill techniques and may increase the risk of injury.
8. Spotting technique should be taught before beginning the weight training program. Divers should pair up and spot (as well as motivate) each other throughout the weight training workout. The body adapts physically to the stress of consistent weight workouts after three to six weeks. Training cycles of this length should be developed for variation and for maximum gains from resistance training. A plan is needed for periodization of a resistance training program during the year in order to (1) vary the intensity, volume, and rest (2) to accommodate the competition schedule of the individual diver, and (3) to increase his/her potential to peak at the right time.
9. Safe and effective resistance training programs should always be integrated into a holistic training program. Proper diet and adequate rest for all divers are important to the safety of the total program. Coaches should keep in mind that young athletes need more rest than normal when involved in a vigorous training program (Martens, Christina, Harvey, & Sharkey, 1981).
10. It is generally a good procedure to administer a flexibility program an hour or more after the resistance training program (Rosenbaum & Hennig, 1995; Siff & Verkhoshansky, 1993). Besides being an effective time to increase flexibility (because the muscles are warm), stretching may also help to relieve sore muscles which tend to reflect participation in the early phase of a resistance training program (de Vries, 1961; de Vries, 1966; Smith, 1994).

## PLYOMETRIC TRAINING FOR DIVERS

For divers, the term plyometrics is often used to refer to jumping drills and medicine ball work (Gater, 1988, 1988-89). The National Strength and Conditioning Association Position Statement on Explosive/Plyometric Exercises (1993) describes the stretch-shortening cycle which is essential in the performance of competitive diving as “*a rapid deceleration of a mass followed almost immediately by rapid acceleration of the mass in the opposite direction. A plyometric exercise program trains the muscles, connective tissue and nervous system to effectively carry out the stretch-shortening cycle*”. Vertical jumping and medicine ball throwing exercises may facilitate safe adaptation to the demands of explosive jumping and somersault initiation characteristic of competitive diving.

The NSCA recommends that:

*“plyometric drills affecting a particular muscle/joint complex (upper body or lower body) should not be performed on consecutive days. Plyometric drills should not be performed when an athlete is fatigued. Time for complete recovery should be allowed between plyometric exercise sets.”*

Divers who engage in formal plyometric training should be completely warmed up beforehand. Just as with learning new dives, divers should follow proper progression. Master simple plyometric drills before moving on to more complex drills.

Well conceived plyometric exercise programs that follow proper training procedures have been found to be no more injurious than other forms of sports training and competition. Generally, depth/drop jumps from excessive heights by heavy or physically unprepared athletes have accounted for most problems (Wathen, 1993). Wathen also reports that:

*“most authorities do not recommend plyometrics on the days of heavy weight training or other intense activity. An estimated minimum strength level of 1.5 to 2.5 times body weight in the free weight squat has been recommended for safe participation in plyometric drills (Bielik, 1986; Chu, 1992; Gambetta, 1978; Santos, 1979; Verhoshanskiy, 1979). Another measure of readiness for lower body plyometrics is the performance of five reps of the squat with 60 percent of body weight in five or less seconds. For upper body drills, the ability to perform five hand clap push-ups should qualify an individual for beginning upper body plyometric drills”.*

Plyometric programs should also utilize the concept of periodization. **Extreme caution in choosing appropriate plyometric drills, correct technique and progression is of the utmost importance to avoid injury when including plyometric training.**

## PLYOMETRIC TRAINING GUIDELINES

1. Divers with orthopedic limitations should check with their doctor before engaging in these drills.
2. Exercise shoes and landing surfaces used should be appropriate to the activity.
3. Beginning divers should start with very low impact plyometric exercises as part of their warm-up. For example they may begin with jogging or running in place, jumping jacks, skipping, or rope-skipping.  
**Keep in mind, diving itself is plyometric in nature.**
4. The intermediate divers with a training age of two full seasons of participation may begin formal plyometric training **ONLY TWICE PER WEEK** with exercises such as squat jumps, jumping up stairs (begin one at a time), tuck jumps (begin one at a time), and medicine ball work. Medicine ball drills should begin with a very light weight ( e.g., a basketball or volleyball first, then a medicine ball weighing about 4-6 lbs.).
5. Reserve more advanced plyometric work (depth jumps) for postpubescent divers who have developed an adequate level of base strength.
6. Follow appropriate progressions for number of foot contacts for all formal plyometric sessions (Stone & O'Bryant, 1987).

## FLEXIBILITY TRAINING

Enhancement of flexibility is done by three basic stretching methods: (a) static stretching, (b) ballistic stretching and (c) proprioceptive neuromuscular facilitation (PNF) stretching (Sands, 1990). All forms of stretching involve placing the muscle on tension by manipulation of the joints (Sands, 1989). When performing stretching exercises, the body moves through its initial maximum range of motion. When approaching the limit, some mild discomfort on the stretching muscles will be felt. Do not take the stretch to the point of pain.

### Static stretching

In static stretching, the limb is placed near its extreme range of motion and then gently and very slowly moved into a more extreme position.

**In static stretching**, the position may be held anywhere from **20 to 60 seconds**, then released, and may be repeated approximately **5-10 times** depending on the needs of the diver. Static stretching is the easiest of the three methods to implement safely.

## Ballistic stretching

Ballistic stretching is generally discouraged due to the involvement of the stretch reflex, which is a protective mechanism of muscle tissue. This reflex actually causes the muscle to contract during an extreme bounce when the athlete is trying to stretch it (Anderson, Beaulieu, Cornelius, Dominguez, Prentice & Wallace, 1984; Astrand & Rodahl, 1977, de Vries, 1966; Sands, 1984, 1990). If ballistic stretching does accompany static stretching, it should be limited to the advanced levels of training and overly rapid and/or forceful motions should be avoided. While “dynamic” stretching which includes large swinging movements and rapid movements to near extreme ranges of motion may benefit athletes who are already very fit (Worrell, Smith & Winegardner, 1994; Holt, Holt & Pelham, 1995; Tenke & Higgins, 1999; Siff, 1998), static stretching is still the most appropriate stretching for beginners.

## PNF Stretching

PNF stretching in most exercises involves the judicious use of a partner. In active PNF stretching the working diver moves a limb close to the extreme range of motion and then contracts the muscle being stretched isometrically for a count of approximately six against the immovable resistance offered by the assisting diver. The working diver then lifts or moves the limb further in the direction of the stretch. In passive PNF stretching, the assisting diver does the lifting or moving (Sands, 1984, 1990).

### FLEXIBILITY GUIDELINES

1. Prior to the actual activity, strive to obtain only current joint ranges of motion using basic warm-up techniques.
2. Following the activity, attempt to slightly increase existing joint ranges of motion by means of a prudent flexibility training program.
3. Train carefully in a graduated and consistent fashion – gradually increase the range of application over an extended period of time. Go slowly!
4. Emphasize those joint sites that are applicable to the broadest category of skills (priority training).
5. Since flexibility is “joint specific,” additional emphasis should be placed on the more inflexible areas.
6. Flexibility training exercises should, as much as possible, closely approximate skill objectives (specificity of training).
7. Static (slow, progressive) stretching is a recommended technique at all levels of training.
8. Judicious stretching with a partner is recommended for advanced levels provided the coach supervises and instructs the proper procedure of gently applying and withdrawing pressure.
9. Proper form and mechanics are essential to prevent injury while stretching.
10. Stretching designed to increase flexibility is most effectively done with warm and fatigued muscles (Bompa, 1983) (e.g., an hour or more after a diving workout, trampoline session, resistance training, jacuzzi, or sauna).

## REFERENCES

- Anderson B, Beaulieu JE, Cornelius WL, Dominguez RH, Prentice WE, Wallace L (1984) Flexibility. National Strength and Conditioning Association Journal, Aug-Sep, 10 (22): 71-73.
- Astrand PO, Rodahl K (1977) Textbook of work physiology. New York, NY: McGraw-Hill.
- Avella DG, DeGeronimo TF (1990) The pre-season medical exam. The Healthy Athlete. British Am Publishing, 77.
- Bielik E et al (1986) Round table: Practical considerations for utilizing plyometrics. Part 1. NSCA Journal 8 (3): 14-22.
- Blum, RW (1985) Preparticipation evaluation of the adolescent athlete. Adolescent Athlete 78 (2) Postgraduate Medicine, 52-69.
- Bompa TO (1983) Theory and methodology of training: the key to athletic performance. Dubuque, IA: Kendall/Hunt Publishing Company.
- Brown M (1990) Performer readiness. In Gabriel JL, George GS (eds.) U.S. Diving Safety Manual. Indianapolis, IN: U.S. Diving Publications, 69-76.
- Cantu R, Micheli LJ (1991) ACSM's Guidelines for the Team Physician. Lea & Febiger, 71-77.
- Chu D (1992) Jumping into Plyometrics. Champaign, IL: Human Kinetics.
- De Vries HA (1961) Electromyographic observations of the effects of static stretching upon muscular distress. Res Quar. 32 (4), 468-479.
- De Vries HA (1966) Physiology of Exercise for Physical Education and Athletics. Dubuque, IA: Wm.C. Brown, p 365.
- Faigenbaum AD, Kraemer WJ, Cahill B, Chandler J, Dziadosz J, Elfrink LD, Forman E, Gaudiose M, Micheli L, Nitka M & Roberts S (1996) Youth resistance training: position statement paper and literature review. In Strength and Conditioning, (December) 62-75.
- Werner G (1998) FINA Handbook 1998-2000. pp. 222.-224. and Addendum (July, 1998)
- Fleck SG, Kraemer WJ (1987) Designing resistance training programs. Champaign, IL: Human Kinetics.
- Gambetta V (1978) Plyometric Training. Track and Field Quarterly Review, 78 (1): 58-59.

- Gater DA (1988) Lecture on: The application of training principles to the skill/power sport of diving. USOC Coaches College on Applied Exercise Physiology. Olympic Training Center, Colorado Springs, CO., 1988-1989.
- Gater DA (1988) Lecture on: Part I: The application of strength/power training principles to diving. Part II: periodization. National Team training Camp, Indianapolis, IN.
- Gater D, Rubin B (1988) Strength and conditioning programs for sports of the Olympic Games. National Strength & Conditioning Association Journal, 10 (4): 7-25.
- Golan R, Falk B, Hoffman JR, Hochberg Z, Ben-Sira D, Barak Y (1998) Resistance training for children and adolescents (Position Statement by The International Federation of Sports Medicine (FIMS). In Chan KM & Micheli LJ (eds): Sports and Children, Hong Kong: International Federation of Sports Medicine. 265-270.
- Hejns WF, Rosenberg A, Bufurusis DG et al. (1982) Prevention of sports injuries in high school students through strength training. Itat Strength Conditioning Assoc 4: 28-31.
- Holt J, Holt LE, Pelham TW (1995): What research tells us about flexibility-I. In Bauer T (ed.): Proceedings XIII International Symposium on Biomechanics in Sports. Dalhousie University, Nova Scotia: International Society of Biomechanics in Sports, 175-179.
- Kearney JT (1987) Coaches' College on Applied Exercise Physiology, Olympic Training Center, Colorado Springs, 1987.
- Kraemer WJ, Deschenes MR, Fleck SJ (1988) Physiological adaptations to resistance exercise. Implications for athletic conditioning. Sports Med. 6: 246-266.
- Major JA, McNeal JR & Sands WA (1996) Physician compliance with physical examinations for national talent-selected female gymnasts age 6-11 years. Proceedings of the North American Society for Pediatric Exercise Medicine, p. 70.
- Malmberg E (1985) Physical readiness. In George GS (ed.): USGF Gymnastics Safety Manual. Indianapolis, IN: The USGF Publications Department, 69-72.
- Mangine RE (1981) Stretching for the competitive diver. In Golden D (ed.): Proceedings of the U.S. Diving Sports Science Seminar, Indianapolis. IN: U.S. Diving, pp. 123-130.
- Mangine RE (1982) Preventative exercises for the back in the competitive diver. In Golden D (ed.): Proceedings of the U.S. Diving Sports Science Seminar, Indianapolis: U.S. Diving, 91-99.
- Martens R, Christina RW, Harvey JJ & Sharkey BJ (1981) Coaching Young Athletes. Champaign, IL: Human Kinetics.
- McCarthy GE, Robinson NJ (1985) Spa and pool safety: a quantitative risk analysis. Prepared for the National Spa and Pool Institute by Failure Analysis Associates. September 3, p. 1.
- McLaughlin T (1981) Strength/power training for U. S. divers, In Golden D (ed.): Proceedings of U.S. Diving Sport Science Symposium, Indianapolis, IN: U.S. Diving, 131-147.
- Micheli LJ (1998) Strength training in the young athlete. In Brown EW & Branta CE (eds.): Competitive Sports for Children and Youth. Champaign, IL: Human Kinetics, pp. 991-105.
- Miller DI (1983) Selected biomechanical aspects of the final approach step, hurdle and take-off of competitors in National Sports Festival V. Report No. 1. Submitted to United States Diving, September 20.
- Miller DI, Jones IC, Pizzimenti MA (1988) Taking off: Greg Louganis' diving style, SOMA: Engineering for the Human Body. 2 (4): 20-28.
- Mueller FO, Ryan AJ (1991) Prevention of Athletic Injuries: The Role of the Sports Medicine Team. F.A. Davis Company.
- National Youth Sports Safety Foundation, Inc. Fact Sheets. Available from the National Youth Sports Safety Foundation, Inc., 333 Longwood Avenue, Suite 202, Boston, MA 02115 617/277-1171 [Http://www.NYSSF.org](http://www.NYSSF.org)
- O'Brien R (1993) Preliminary talent identification test development: physical performance measures of junior olympic divers. In Malina R, Gabriel JL (eds.) U.S. Diving Sport Science Seminar Proceedings. Indianapolis, IN: U.S. Diving Publications, 17-25.
- Preparticipation Evaluation, The Pediatric Athlete. (1990) In Sullivan JA, Grana WA (ed.): The American Academy of Orthopaedic Surgeons Seminar, 53-61.
- Preparticipation Physical evaluation (1992) A joint publication of the American Academy of Family physicians, American Academy of Pediatrics, American Medical Society for Sports Medicine, American Orthopaedic Society for Sports Medicine, American Osteopathic Academy of Sports Medicine. Available from the American Academy of Pediatrics, 141 Northwest Point Boulevard, Box 927, Elk Grove Village, IL 60009, 800-433-9016.

- Rabinovitch P, McLean EB, Beck GR & Brown AC (1978) Recurrent preretinal hemorrhages following a negative “g” maneuver on school playground equipment. *J. Pediatr* 92 846-853.
- Rosenbaum D, Hennig EM (1995) The influence of stretching and warm-up exercises on Achilles tendon reflex activity. *J Sports Sci.* 13, 481-490.
- Sale DG, Norman RW (1982) Testing strength and power. In MacDougall JD, Wenger HA, Green HJ (eds): *Physiological Testing of the Elite Athlete*. Ithaca, NY: Movement Publications, 7-38.
- Sands WA (1984) *Coaching Women’s Gymnastics*. Champaign, IL: Human Kinetics Publishers.
- Sands WA (1989) *Conditioning for Gymnastics, Report to the USGF*.
- Sands WA (1990) Performer readiness. In George GS (ed.): *USGF Gymnastics Safety Manual*, Indianapolis, IN: The USGF Publications Department, (2nd Edition).
- Santos J (1979) Jump training for speed and neuromuscular development. *Track and Field Quarterly Review*, 79 (1): 59.
- Sawyer TH (1992) Legal Issues in Coaching. In Seefeldt V, Brown EW (eds.): *Program for Athletic Coaches’ Education Reference Manual*, Dubuque, IA: Wm.C. Brown Communications, Inc. 25-7.
- Siff MC (1998) Facts and fallacies of fitness. *The School of Mechanical Engineering, University of Witwatersrand, Johannesburg, South Africa*.
- Siff MC, Verkoshansky (1993) *Supertraining*. The School of Mechanical Engineering, University of Witwatersrand, Johannesburg, South Africa, 487.
- Smith CA (1994) The warm-up procedure: to stretch or not to stretch. A brief review. *JOSPT* 19 (1) 12-17.
- Stone M, O’Bryant H (1987) *Weight Training: a scientific approach*. Edina, MN: Burgess International Group, Inc., p. 98 & 121.
- Tanner GM (1967) *Growth and Adolescence* (2nd Edition). Oxford: Blackwell Scientific Pub.
- Team Physician Curriculum of the American College of Sports Medicine (ACSM), ACSM, Box 1440, Indianapolis, IN 46206, 317/637-9200.
- Tenke Z, Higgins A (1999) *Warm-up and preparation for athletes of all sports*. Sports Books Publishers, Toronto, Canada.
- Thomas KA (1983) Screening the child for sports participation. *Issues in Comprehensive Pediatric Nursing*, 6:179.
- Unitas J, Dintiman G (1979) *Improving health and performance in the athlete*. Englewood Cliffs, NJ: Prentice Hall.
- U.S. Diving Rules & Regulations (1998-1999) J:05-J:11, S:07-S:10, M:01-M:05.
- Verhoshanskiy Y (1979) Depth jumping in the training of jumpers. *Track and Field Quarterly Review* 79 (1): 60.
- Vinger P (1994) *The Eye and Sports Medicine*. Duane’s Clinical Ophthalmology. J.B. Lippincott Co. p. 66
- Visual Skills (1988) *USOC Sports Mediscope*, 7 (6): 2.
- Vosler KD (1985) *A Year Round Training Program for Diving* (A practical handbook for competitive diving coaches). Limited edition.
- Wathen D (1993) National Strength and Conditioning Association Position statement on Explosive/Plyometric Exercises. *National Strength and Conditioning Association Journal* 15 (3) 16-19.
- Whitlock S (1998) Physical readiness. In *USA Gymnastics Safety Handbook*. Indianapolis, IN USA Gymnastics Publications, 68-72.
- Worrell TW, Smith TL & Wingardner J (1994) Effect of hamstring stretching on hamstring muscle performance. *JOSPT* 20 (3), 154-159.
- Zatsiorsky VM (1995) *Science and Practice of Strength Training*. Champaign, IL: Human Kinetics, 190.

# Part 3. Injury Management

by Gerald E. DeMers, Ph.D.

## MANAGEMENT OF DIVING INJURIES

Poor management of an athletic injury can contribute to such misfortunes as delayed healing, an unstable or weakened body area, compromised training and performance, or more seriously, permanent disability or possibly death. The body's immediate and long-term responses to physical trauma are essentially the same for all types of athletic injuries; that is, inflammation followed by healing. The physiologic and anatomic changes that characterize each step are reliable and predictable indicators from which a trained observer can deduce a great deal of information both about the initial injury and the subsequent course of the recovery process. The body's basic response to a traumatic athletic injury is illustrated in Figure 8.3.1. This cycle outlines the sequence of events following an injury. Depending on the severity of the injury and the management procedures used, this cycle can vary greatly in its length and conclude in less-than-optimal recovery and possibly reinjury or permanent loss of function. Ideally, the end result is optimal recovery.

The majority of diving injuries are caused by some type of trauma. Traumatic forces include:

- compression or loading,
- tension or fracture, and
- torsion or shear.

The physical signs of acute injuries (bleeding, swelling, joint deformity) tend to be more obvious than the symptoms of overuse injury (pain, achiness, fatigue). Since acute injuries occur from a recognizable event and have obvious signs of injury, they are more likely to come to medical attention than the more subtle overuse injuries. Nonetheless, it is critical to recognize both types of injuries and see that both get the early medical attention necessary for an optimal recovery.

Injuries (both acute and overuse) result in pain, inflammation, and loss of motion, strength, and normal function. Treatment must address each component of the injury including:

- control of pain and inflammation,
- restoration of integrated function (including sport-specific skills),
- restoration of strength and fitness.

Treatment that involves just rest or use of medications may not effectively restore full function after an injury. In fact, resting alone may increase the risk of further injury by causing stiffness, weakness, and deconditioning.

The first stage in the recovery process is to protect the injured area from further trauma and to control inflammation. The inflammatory process is an important defense mechanism that occurs for a specific purpose, namely to protect and heal an injured area. The five cardinal signs of inflammation are:

- redness
- swelling
- heat
- pain
- loss of function

These signs serve to remind an athlete that he or she has been injured and are present to prevent the athlete from exceeding safe limits of activity. Inflammation rids the injured area of waste products and prepares the body for healing.

## Pain-spasm cycle

An additional response to trauma is the pain-spasm cycle. Generally, pain and muscle spasm of varying degrees accompany musculoskeletal injuries. Muscle spasm is a protective mechanism, designed to prevent further damage to an already injured area. The body attempts to splint the area surrounding the injury through the involuntary contraction of muscles or groups of muscles. The resulting contraction is called muscle spasm. As the muscle spasm develops, there is increased pressure on the nerve endings, resulting in pain. The body responds to the increased pain with increased muscle spasms, resulting in more pain, and so on; hence the name pain-spasm cycle.

## THE PROCESS OF WOUND HEALING

Rehabilitation will differ, depending on the type of tissues injured. Injuries involving the contractile unit (muscles and tendons) are treated and managed differently than those involving noncontractile tissues such as ligaments. Range of motion exercises for muscles/tendons or ligaments should be started when the physician indicates it is permissible. If muscles and tendons are allowed to heal without active early motion, it may be very difficult to restore full strength and range of motion. Starting too early may impede healing, cause

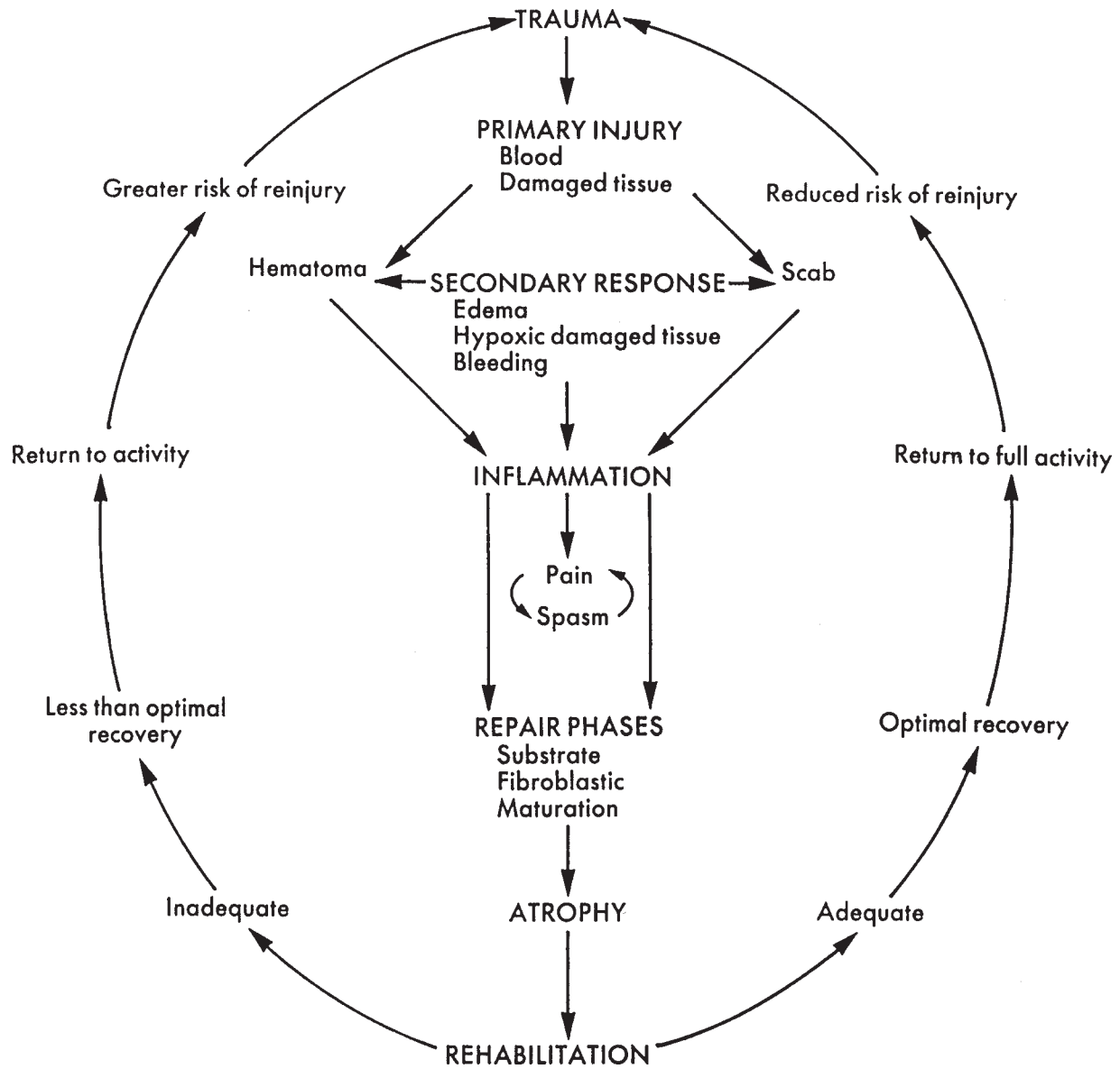

Figure 8.3.1 Cycle of an Athletic Injury from Boohar & Thibodeau, *Athletic Injury Assessment*

additional hemorrhaging and swelling, and result in a bigger scar and possibly a limitation in function. Allowing the muscle/tendon unit to heal in a shortened state will result in a loss of motion making the athlete more vulnerable to repeated strains.

Ligament injuries require a long period of time (possibly 6 months) to heal. If ligaments are subjected to abnormal stresses early in the healing process, the developing scar tissue may elongate, resulting in some degree of permanent instability of the involved joint. Too much rest or too much use may be harmful. The coach should be communicating with the treating physician or physical therapist to ensure that the diver is finding the correct balance for his/her particular injury and phase of recovery.

Another result of the injury cycle that a diving coach must be aware of is *atrophy*. Atrophy is the wasting away or deterioration of muscle/tendon tissue. During healing, if the injured area has been immobilized or otherwise inactive, atrophy will occur. In most cases the degree of atrophy is directly proportional to the amount and time of immobilization. An area of the body that has atrophied is more susceptible to reinjury. Thus, the injured diver should not be returned to full diving activity until the area has been rehabilitated optimally.

## FRACTURE HEALING

It is vital not to rush recovery. Time is required for proper bone union to take place. During healing, fractures can keep an athlete out of participation for several weeks or months, depending on its nature, extent, and site. During this period there are certain conditions that can seriously interfere with healing. One of these conditions is poor immobilization of the fracture site. This can be caused by poor application of a cast or too much activity in the injured area.

Allow ample time for fractures to heal before attempting any diving activity. Follow the directions of the physician about when the diver can resume training.

## CRITERIA FOR FULL RECOVERY

In addition to following the general guidelines presented in Part 1 (see p. 125) for return to diving after an orthopedic injury, it is important that the diver has regained the confidence to return. Sometimes this phase of recovery is a long and tedious process for both the coach and the diver. The restoration of confidence is important but does not necessarily come with patience alone. This is an area where the coach may be a great help to the physician or therapist.

Regardless of the type of injury from which the diver is recovering, the coach plays a major part in the healing process. Follow the directions of the athletic trainer or physician. Ask what can be done to maintain fitness without jeopardizing healing. Progressively work the diver toward full participation in diving activities. If swelling or inflammation returns, they are indications that healing is not complete. Allow more time for healing and avoid reinjury or producing a chronic injury.

## PSYCHOLOGICAL RESPONSES TO TRAUMA

Coaches must consider the psychological responses of the diver to physical trauma and pain. Athletes react to physical trauma in different ways. Perceived changes in movement patterns, gait, appearance, and functional ability all contribute to the psychological reality of injury. Some may perceive an athletic injury as a disaster, whereas others may find it a welcome relief from poor performance. Athletes can undergo a variety of psychological reactions to an injury, such as anger, disbelief, denial, alienation, depression, isolation, resignation, or acceptance. In fact, an athlete may go through all of these reactions during a single injury. Some of these reactions can develop into a self-defeating attitude and become blocking forces to effective recovery and rehabilitation. Athletes may lack motivation to recover and wonder if they ever will completely recover and compete again. Coaches must be aware that these factors can greatly affect the physiologic responses to trauma. Recovery depends on the proper psychological attitude as well as on the physiologic processes involved. Coaches should combine physiologic healing processes with a positive, encouraging attitude in an attempt to effectively care for the mind as well as the body.

## SUMMARY

The coach plays an important role in the healing process. They are most important in initial recognition of an injury, first aid care, ensuring compliance with rehabilitation programs, and making the transition back to full activity. The coach must also consider the psychological effects the trauma of the injury has had on the diver involved, other diving team members, assistant coaches, other personnel involved in the incident and effects on the coach him- or herself.

The diver's ability to recover physiologically and psychologically is affected by how the diving coach approaches the road to recovery. A positive and caring approach will benefit all.

## REFERENCES

- Arnheim DD (1989) *Modern Principles of Athletic Training*. St. Louis, MO: Times/Mirror/Mosby College Publishing.
- Booher JM, Thibodeau GA (1985) *Athletic Injury Assessment*. St. Louis, MO: Times Mirror/Mosby College Publishing.
- Everstine D, Everstine L (1993) *The Trauma Response*. New York: W.W. Norton and Co.
- Rubin B (1990) Orthopedic care. In Gabriel JL, George GS (eds.): *U.S. Diving Safety Manual*. Indianapolis, IN: U.S. Diving Publications, p. 27.
- Wilson JP (1989) *Trauma: Transformation and Healing*. New York: Brunner/Mazel Publishers.
- Wilson J, Kahana B (eds.) (1988) *Human Adaptation to Extreme Stress*. New York: Plenum Press.
- Wolman B, Stricker G (eds.) (1994) *Anxiety and Related Disorders*. New York: John Wiley and Sons, Inc.



# SECTION III: EMERGENCY RESPONSE AND CARE OF COMPETITIVE DIVING INJURIES

## SECTION STANDARDS

### Upon completion of this section, coaches should know:

- The scope of their legal responsibilities concerning emergency response and first aid care of competitive diving injuries.*
- To implement procedures for appropriate emergency care.*
- To demonstrate skill in recognition and evaluation of competitive diving injuries and the ability to assist divers with the recovery/rehabilitation from injuries that are generally associated with participation in diving in accordance with the guidelines provided by qualified medical personnel.*
- To minimize exposure to the risk of injuries by considering the effects of environmental conditions on the circulatory and respiratory systems when implementing programs for physical conditioning.*



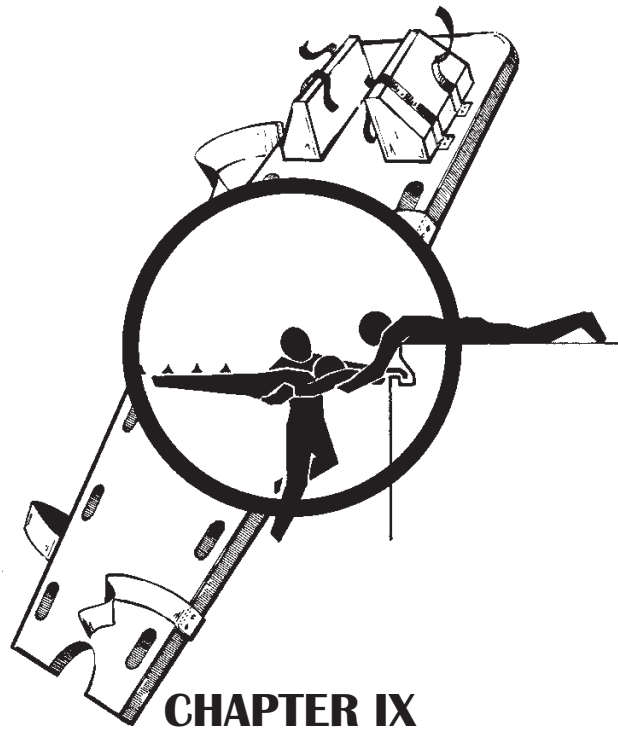

## CHAPTER IX EMERGENCY RESPONSE

by Gerald E. DeMers, Ph.D.

### CHAPTER COMPETENCIES

#### Upon completion of this chapter, coaches should be able to:

- Follow safety guidelines, procedures and risk management plans established by program administrators.
- Know their responsibilities in first aid, CPR and emergency procedures.
- Execute the established emergency plan for the organization/activity/situation.
- Have knowledge of first aid and CPR, or have immediate access to someone who is first aid/CPR qualified.
- Know how to recognize and respond to symptoms of injuries that may occur in diving.
- \*Have backboards with appropriate straps and head restraints available at all practices and competitions.
- Know the location of the nearest telephone.
- Know when professional medical care is required for an injured diver.

*\*(Option A) Demonstrate in water skills — extension assist, reaching assist, throwing assist, unconscious victim underwater armpit tow to pool side, unconscious victim on surface rescue with rescue tube, removal of unconscious victim from the water, upper & lower extremity injury rescue, conscious victim rear approach with rescue tube, removal of upper & lower extremity injury victims from water, head-splint supine & prone rescue on the surface, head-splint rescue underwater, backboarding in deep water.*

*or*

*(Option B) Assist on deck (in-water physical skills not demonstrated) — assist rescues within the physical limitation of the participant, knowledge of rescue procedures and knowledge of deep water backboarding procedures.*

# Part 1. Responding to Diving Related Emergencies

Coaches are considered lay responders, i.e. rescuers or first aiders, who provide *care*. Coaches are not expected to provide *treatment*, which is care rendered by professional medical personnel. Coaches are not expected to have the medical expertise of a fully trained and licensed medical provider or practitioner, but it is helpful for them to have at least a working knowledge of the potential injuries and problem areas associated with diving. Assessment of an injury is difficult, especially when the victim is immersed in water. Accordingly, the initial assessment of the victim in water may vary somewhat from what is taught in the ARC Sport Safety Training program. A quick review of the ARC Sport Safety Training texts will help identify specific areas of concern for diving. This chapter will address the coach's role in the EMS system.

## THE COACH'S ROLE IN THE EMS SYSTEM

Most often the diving coach has seen the injury happen. This is an advantage in assessing the injury and responding in an appropriate manner. In some circumstances, the coach may not observe the incident, in which case the response will be somewhat different. The following information will assist the coach in recognizing that an emergency exists, deciding to act, taking action, assessing the severity of the injury, planning for first aid care, and deciding to transport the injured athlete.

### Recognize that an emergency exists

Consider the following:

- the injury or sudden illness
- unusual noises, sights, or odors
- diver's appearance and behavior
- site of the injury
- manner in which the diver was injured
- location of the victim

### Initial Reaction

It is your duty to respond in an emergency. Be certain that you review rescue and first aid skills periodically so that you perform a rescue and give care effectively and prudently.

- Protect yourself adequately from blood-borne pathogens.
- Call 911 or the local emergency number for help.
- Provide first aid care until help arrives.

### Taking Action

Three basic steps:

**Check the scene for safety; check the injured diver, protect the victim from further injury.**

**Call or designate someone to call 911 or the local emergency number when appropriate.**

**Care for the injured or ill diver.**

Following the correct steps minimizes confusion at the scene of an emergency.

### Check

Answer these questions:

- Is the scene safe?
- Is the diver protected from further injury?
- What happened?
- Is there more than one injured diver?
- Can bystanders or other divers on the scene help?

### Call

Call 911 or the local emergency number if the injured diver:

- Is not breathing.
- Has no pulse.
- Is or becomes unconscious.
- Has breathing difficulty or is breathing irregularly.
- Has chest pain or pressure.
- Is bleeding severely.
- Has pressure or pain in the abdomen that does not go away.
- Is vomiting or passing blood.
- Has seizures, a severe headache, or slurred speech.
- Has injuries to the head, neck or back.
- Has possible broken bones.
- Also call 911 for any of these situations:
- Presence of poisonous gas.
- Injured or ill diver who cannot be moved easily.
- Unconscious for any period of time underwater.
- Review "How to Call EMS Personnel" in ARC Sport Safety Training Workbook p. 3.

### Care

Always keep a well-stocked first aid kit on hand (see ARC Sport Safety Training Handbook, p. xi).

- If necessary, send someone to call EMS personnel.
- Care for life-threatening emergencies.
- Monitor for changes in breathing and level of consciousness.
- Help the diver rest in a comfortable position.
- Keep the diver from getting chilled or overheated.

If you are certain there is no head or neck injury the injured diver should be removed from the water in order to provide care if proper support can be given. More specific information relating to checking the athlete can be found in ARC Sport Safety Training Workbook pp. 8-12.

## Assessing the Severity of the Injury

Diving injuries vary from minor to catastrophic. It is important that the coach be able to assess the extent of the injury in order to make appropriate decisions about care. If the diver is conscious and able to talk, he or she is breathing and has a pulse. Scan the diver for severe bleeding.

Before removing a conscious diver from the water after an injury, do a visual inspection, talk to the diver, and conduct a head to toe evaluation. Instruct the diver not to move any area where there is pain. Visually inspect the diver's head for bumps, bruises, bleeding, bone protrusions, and abnormalities. The following are examples of questions which may be asked in order to better assess the extent of the injury:

- Do you have pain anywhere?
- Do you know what happened?
- Do you know where you are?
- Do you feel light-headed or dizzy?
- Are you nauseous or sick to your stomach?
- Can you open your eyes?
- Can you see normally?
- Can you hear normally?
- Can you shrug your shoulders?
- Can you take a deep breath?
- Can you move your arms?
- Can you move your hands?
- Can you move your fingers?
- Can you pull your knee toward you chest?
- Can you move your foot?
- Can you move your toes?
- Do you have numbness or tingling anywhere?

There may be other questions to ask which relate to the type of injury observed. Questions will assist you in deciding whether or not you can move the victim from the water to the deck.

If the diver is unconscious, your observation of what caused the injury will dictate the type of care you give. Whether the injury was observed or not, any suspicion of a neck or back injury warrants in-line stabilization and backboarding before removing him or her from the water (see Chapter 9.3 for details of spinal injury management). Since the diver will be close to the edge of the pool, in situations where there is not a suspected spinal injury, remove the diver from the water as soon as a head or neck injury has been ruled out. **After the unconscious diver is on deck do the following:**

- Roll the diver onto his or her back.**
- Open the airway, look, listen and feel for breathing.**
- If not breathing, give two full breaths.**
- Check the pulse.**
- Check for severe bleeding.**
- If no pulse, start CPR.**
- See pages 18-20 and 31-37 in [ARC Sport Safety Training Workbook](#).

## Plan for First Aid Care

Planning ahead can save valuable time in the care of an injury. A first aid kit should be at the scene for all diving practices and competitions. Do not rely on the facility to maintain a first aid kit. The best method to assure that you have proper first aid equipment is to carry a first aid kit with you to all diving activities. If you use any material from the kit, be sure to replace it.

Dry blankets and/or towels should be available to help the injured diver retain body heat after an injury. Since the diver is wet in the majority of injury scenarios, it is likely he or she will get cold while being cared for on the deck. Towels or blankets will be valuable if the diver goes into shock.

Be certain a rescue tube is immediately available for use. This device will provide good flotation for the injured diver and rescuer. A backboard with the appropriate number of straps and a head-immobilizer must also be available on deck. Cervical collars in a variety of sizes are also needed in case of a suspected spinal injury. There are now adjustable collars available for purchase.

If ice is not immediately available, know where you can get some. You may also choose to store chemical cold-packs in a first aid kit. Ice may be used to control swelling. Have latex gloves, bandages, dressings, resuscitation mask, eye shield, and other first aid equipment readily available for use.

Review your emergency action plans periodically. This will assist you in taking decisive actions promptly. There should be a telephone available on the pool deck or accessible from a swimming pool office. If a phone is not available in the facility, consider carrying a cellular phone. Emergency phone numbers should be posted at the location of the telephone along with printed directions for easy access if needed, such as what number to press to make available a phone line designated for outgoing calls and dial tone.

Review your rescue, first aid and CPR skills; recertify periodically. In an emergency, it is easy to panic and forget proper techniques. The more you review and practice these skills, the more likely it is that you will act properly in an emergency.

Contact your local EMS System and determine its policies for the type of care you should provide before their arrival at the scene. Know where the quickest access from the street is located and share that information with EMS. Know where the easiest access to the swimming pool is located. Access should be large enough for a gurney to pass through.

Incident and accident report forms should be available for use (see pages 24 and 25). Be certain to complete the form in a timely manner and as thoroughly as possible. Know how to document and report any sports injury or illness (see [ARC Sport Safety Training Handbook](#), p. 50).

## Deciding to Transport the Injured Diver

It is important to exercise judgement when deciding whether to transport the injured diver. One consideration is

the severity of the injury or illness. Simple athletic injuries, particularly to the upper extremities, generally do not need emergency transport. **Serious injuries of the upper extremities; unstable fractures; dislocations; head, neck, and back injuries; possible internal injuries; injuries of the lower extremities; and any injury resulting in loss of pulse or sensation may require specialized skill and equipment during transport to a medical facility. In these situations, EMS should transport the victim to a hospital.**

## **GUIDELINES FOR TRANSPORTING INJURED ATHLETES**

These guidelines may be found in ARC Sport Safety Training Handbook, p 54. Some of the principles have been altered in this text to reflect the aquatic environment.

- DO NOT move an athlete with a serious head injury or suspected neck or back injury. If the injured diver is in the water, follow the procedures discussed in Chapter 4 of this text.

- If you have doubts regarding the seriousness of an injury or illness or how to care for an injury or illness, wait for professional medical help. Provide appropriate first aid or CPR until help arrives.

- Immobilize and protect any musculoskeletal injury and wait for EMS to arrive. They will have the necessary equipment for splinting. In many situations, the location of EMS is minutes away.

- Allow other athletes to provide assistance to an injured or ill athlete only by following your instructions.

- Have at least two persons (coach, athlete, parent) accompany the injured athlete when he or she is being transported by anyone other than EMS personnel.

The person in charge of a rescue or emergency situation should be clearly identified. If someone with more experience or skill arrives, the transfer of responsibility for first aid care should be clearly communicated.

For optimal protection of the injured athlete during transport, call EMS. They can assess the injury and decide whether the diver should be transported to the hospital for more advanced treatment. In many parts of the country, EMS will not charge a fee unless they provide care. Their arrival at the scene of the injury does not necessarily mean a fee will be charged. Call your local ambulance company or Emergency Medical Services System to determine the policies in your area. The possibility of being charged a fee should not be a factor in using EMS for an emergency.

## **SUMMARY**

The diving coach is generally the first person to respond in a diving emergency. It is important that you be able to recognize that an emergency exists and respond promptly and prudently. Your ability to assess the severity of the injury and plan for first aid care depends on the protocol you have established for emergency care. You will need to decide if emergency transportation is necessary or if another mode of travel is possible. These decisions are based on your perceptions and knowledge of proper responses to an emergency.

## **REFERENCES**

American Red Cross (1996) First Aid: Responding to Emergencies. (Second Edition), St. Louis, MO: Mosby/Lifeline.

American Red Cross (1997) Sport Safety Training Handbook, St. Louis, MO: Mosby/Lifeline.

American Red Cross (1997) Sport Safety Training Workbook, St. Louis, MO: Mosby/Lifeline.

## Part 2. Rescue Techniques for Injured Divers

Competitive divers may incur many sorts of injuries, from minor to catastrophic ones. In some situations, the coach will have to perform a rescue of a conscious or unconscious diver. The coach needs to be familiar with rescue techniques which can be adapted to any injury situation. This chapter will address how to identify a distressed swimmer, an active or passive victim. It will also address types of rescue equipment, non-swimming assists, entering the water, approaching the victim, rescue techniques, and removal of the victim from the water.

### IDENTIFYING A DISTRESSED DIVER AND AN ACTIVE OR PASSIVE VICTIM

Drownings are highly unlikely in competitive diving; however, there are some characteristics of a drowning victim which should be known. An active drowning victim goes through certain phases. This is known as the “instinctive drowning response” (ARC, 1995). Recognition of the “instinctive drowning response” will allow the coach to act quickly and decisively in an emergency.

#### Distressed Swimmer

A diver may become a distressed swimmer if an injury prevents the diver from swimming normally. Any injury to the head, abdomen, back, neck, chest or extremities may cause the diver to become a distressed swimmer. **A distressed swimmer makes little or no forward progress and cannot reach safety without assistance.**

You can recognize distressed swimmers by the way they try to support themselves in the water. **They may float or use swimming skills such as sculling or treading water.** If a lifeline or other floating object is nearby, a distressed swimmer may cling to it for support. Depending on the method used for support, the distressed swimmer’s body may be horizontal, vertical, or diagonal. **The distressed swimmer usually has enough control of the arms and legs so that he or she can keep the face out of the water to continue breathing and call for help.** If a distressed swimmer is not rescued, he or she may become an active drowning victim.

#### Active Drowning

An active drowning victim struggles at the surface in a highly predictable fashion. A video, [The Reasons People Drown](#), by Frank Pia, illustrates the sequences which take place during a drowning. Knowledge of this response gives you a distinct advantage in recognizing active drowning victims. The instinctive drowning response has four characteristics. A drowning person:

- Struggles to keep the face above water in an effort to breathe. Unable to do this, he or she begins to suffocate.
- Has arms extended to the side and presses down for support.
- Has no supporting kick.
- Has a vertical body position in the water.**
- Struggles at the surface and is unable to move forward for approximately 20 to 60 seconds before submerging.**

An active drowning victim is struggling to breathe. The mouth repeatedly sinks below the surface and reappears. While the mouth is below the surface, the drowning person keeps it closed to avoid swallowing water. When the mouth is above the surface, the drowning person quickly exhales and then attempts to inhale before the mouth starts to go below the surface again.

While the victim is gasping for air, he or she also may take water into the mouth. Some of this water may enter the windpipe (trachea) and produce a spasm of the vocal cords (laryngospasm) that will block the airway. This is the body’s natural way of keeping fluid or food out of the airway. Unfortunately, this may result in the victim suffocating and losing consciousness.

**Active drowning victims cannot call for help.** With their body positioned low in the water, they can barely take in enough air to breathe. Breathing takes priority over speaking or yelling.

The active drowning person uses an instinctive arm motion to stay at the surface. The arms are extended out to the side, where they are pressed down against the water to enable the person to raise the mouth out of the water. These arm movements are not under the drowning person’s control. In contrast to the distressed swimmer, the active drowning person cannot wave for help. In addition, the active drowning person does not have an effective kick supporting him or her in the water. The active drowning victim’s body is vertical in the water. This allows the mouth to be at the highest point to provide the greatest chance for the person to breathe.

Finally, an active drowning victim does not make any forward progress in the water. All the person’s energy is devoted to keeping the mouth above the surface of the water. The active drowning person usually stays at the surface for only 10 to 60 seconds. The active drowning victim may continue to struggle underwater but will eventually lose consciousness and stop moving (ARC, 1995).

Situations in which a diver could become an active drowning victim are not common but are possible. A diver with a spinal injury resulting in paralysis will not go through the patterns of an active drowning victim. They may struggle at the surface briefly and then sink below the surface. Divers with fractured bones may have difficulty staying at the surface and could become an active drowning victim quickly. Shock due to trauma may cause the diver to be disoriented, which could cause a drowning situation. Impact with the water may cause the diver to inhale water and lead to drowning. The coach needs to be aware of the instinctive drowning response and take the necessary steps to rescue the diver as quickly as possible.

### Passive Drowning Victim

A passive drowning victim is someone who slips below the surface of the water without warning or any sign of a struggle. Passive drowning may result from the diver being rendered unconscious due to hitting his or her head, sudden illness such as passing out, hard impact with the water causing a blackout or unconsciousness, or shock due to trauma. The most important thing to remember is that you need to be aware that passive drowning is possible in competitive diving.

All potential drownings call for immediate activation of the emergency action plan. By understanding the signs and behaviors that take place in a drowning emergency, the coach can provide proper care quickly.

### RESCUE EQUIPMENT

The facility where you coach should have a variety of rescue equipment available for your use. It is highly recommended that you place the equipment in a location which is easily accessible. Consult with the facility manager to determine if the equipment may be moved to a desirable location. If the facility does not have rescue equipment available for your use, purchase your own equipment. Rescue equipment is reasonably priced and if you purchase your own, you are assured of its availability. Equipment which can be used in an emergency include a rescue tube, reach pole and a shepherd's crook.

### Rescue Tube

A rescue tube is one of the most versatile pieces of equipment used for rescues. It can be used for reaching to a distressed victim, towing a passive victim, or supporting the rescuer. Although sizes and shapes vary, a typical rescue tube is made of buoyant molded foam, 3 1/2 inches by 5 1/2 inches by 45 inches. Many have a line with a loop attached to one end. The line may vary in length depending on the depth of the water in which it will be used (YMCA, 1997).

Rescue equipment reduces the risk of harm to the rescuer and provides support for both the victim and the rescuer. It also makes it easier to tow the victim to safety (See Figure 9.2.1)

### Shepherd's Crook and Reach Pole

The shepherd's crook (see Figure 9.2.2) and reach pole are lightweight wood, aluminum, or fiberglass rods 10 to 15 feet long. The shepherd's crook has a blunt hook on one end that is large enough to place around an unconscious victim for transport to the side of the pool. Both the shepherd's crook and pole may be used to assist a conscious victim.

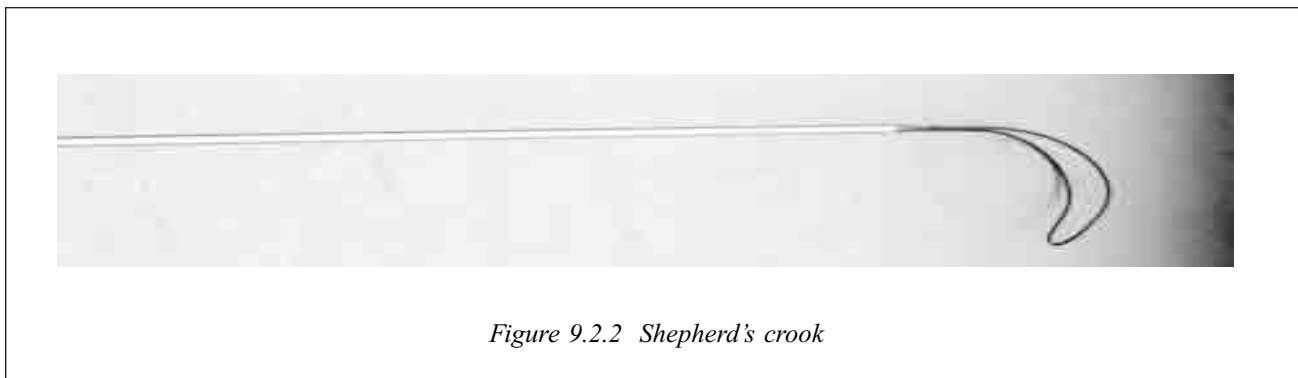
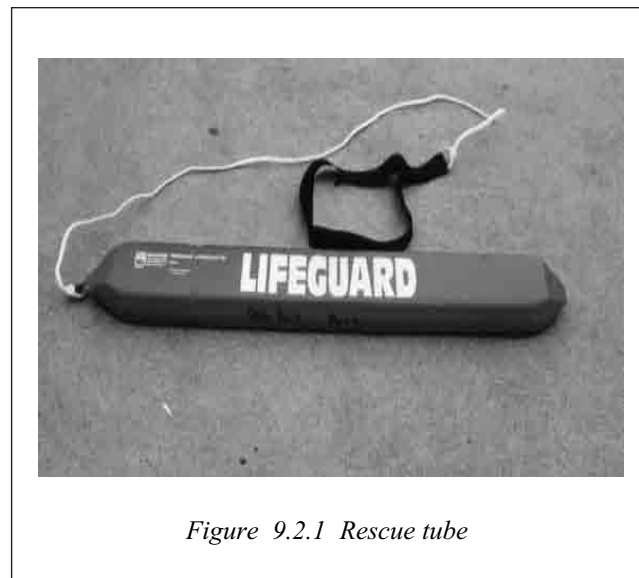

## NON-SWIMMING ASSISTS

The safest way to perform a rescue is using non-swimming assists. If at all possible, this type of rescue should be performed. Non-swimming assists are safer for the rescuer and still provide the necessary support for the victim.

### Reaching and Extension

There are some basic principles which should be followed when performing a reaching or extension assist. There should be no suspicion of a spinal injury. The victim must be fairly close to the side of the pool in order to perform this type of rescue.

---

**Make certain you have a stable base of support. Stay low.**

**Extend or reach in a manner which will not involve the diver's injured limb.**

**Pull the victim to the side of the pool slowly.**

---

To perform a reaching assist out of the water, lay down on the deck and spread your legs to establish a wide base. Extend one hand to the victim. Grasp the victim and pull him or her to the side of the pool (See Figure 9.2.3).

**If extending a reach pole or shepherd's crook to a conscious diver, place one foot forward and one foot back. Stay low. Extend the pole and position it under the diver's armpit so he or she can clamp down on it.** Pull them hand-over-hand to the side of the pool (See Figure 9.2.4). If the diver is unconscious, enter the water with a rescue tube as will be learned later in this chapter.

Another reaching assist can be performed in the water. Enter the water and hold onto the pool gutter. Extend your hand to the victim and pull him or her to the side of the pool. If the victim is farther away, extend your foot to the victim, have it grasped, and then pull to the side of the pool (See Figures 9.2.5 and 9.2.6).



Figure 9.2.3 Reaching assist from pool deck



Figure 9.2.4 Extension assist: shepherd's crook



Figure 9.2.5 Reaching assist in water



Figure 9.2.6 Extending leg to victim



Figure 9.2.7 Throwing assist



Figure 9.2.8 Holding the rescue tube



Figure 9.2.9 Stride jump

## Throwing Assist

A throwing assist may be made if the diver is within six feet of the side of the pool. Using a rescue tube, grasp the shoulder harness on its line. Toss the tube to the distressed victim and tell him or her to grab it. Pull the victim slowly to the side of the pool (See Figure 9.2.7). An active drowning victim will not be able to grasp onto the rescue tube without assistance from the rescuer. It may be necessary for the rescuer to enter the water and insert the rescue tube under the arm of the victim. A distressed victim most likely will be able to grasp the rescue tube.

## SWIMMING ASSISTS

There are situations where non-swimming assists will not be possible or appropriate. All swimming assists should be performed with a rescue tube. The proper use of a rescue tube will provide the rescuer and the victim with adequate flotation for transport to the side of the pool. The following procedures should be used if you must enter the water and swim to the victim in order to perform a rescue.

## ENTERING THE WATER

### Stride Jump

Hold onto the rescue tube as shown in Figure 9.2.8. Stride out away from the side of the pool (See Figure 9.2.9). Lean forward slightly. Kick your feet together as you enter the water. This action will allow the rescuer to keep his or her head above the surface and to keep one's eyes on the victim.

### Waveless Entry

If the victim is fairly close to the side of the pool, it may be detrimental to jump into the water and create waves, especially if a spinal injury is suspected. The waveless entry is performed by sitting on the side of the pool and carefully slipping into the water. This is done by turning and facing the side of the pool as you lower yourself into the water (see figure 9.2.10).

### APPROACHING THE VICTIM

While keeping the rescue tube in front of you with one hand, swim to the victim using a modified breaststroke or front crawl (See Figure 9.2.11).



Figure 9.2.10 Waveless entry



Figure 9.2.11 Approaching the victim



## RESCUE TECHNIQUES

### Unconscious Victim on the Surface

In most situations, if the victim is unconscious on the surface, a spinal injury should be suspected. If you suspect a spinal injury, follow the procedures discussed in chapter 9.3. If no spinal injury is suspected, as you approach the victim, place the rescue tube across your chest and under your armpits. Approach the victim from the side and grasp under both arms. Trap the victim against the rescue tube and against your chest. Role the victim to a supine (face-up) position on top of the rescue tube (See Figure 9.2.12). Tow the victim to the side of the swimming pool.



### Unconscious Victim Under Water or on the Bottom

If the victim is underwater, approach the victim from the rear. If you do not suspect a spinal injury, enter the water without the rescue tube and grab the victim's armpit with one hand (right hand to right armpit or left hand to left armpit) and swim to the surface. Once at the surface, swim the victim to the side of the pool using a breaststroke, scissors, or rotary (eggbeater) kick (See Figure 9.2.13). Use your free hand to assist you in the swim to the side.



Figure 9.2.13 Armpit tow

Figure 9.2.12 Rescue of an unconscious victim on the surface

## Removal from the Water

Once you reach the side of the pool, turn the victim to face the wall and position yourself to the rear of the victim. Reach under the victim's arms and grab the side of the pool to support the victim. You can also support the victim on your knee (See Figure 9.2.14). Instruct an assistant or other diver to grab the victim's wrists and lift him or her so that the face will stay out of the water (See Figure 9.2.15). Climb out of the water and grasp one of the victim's arms while the assistant holds onto the other arm. Both rescuers should grasp the wrist and upper arm of the victim. On a count of 1, 2, 3, simultaneously lift the victim up and onto the deck. Lift until the victim's knees or mid-thighs are on the deck (See Figure 9.2.16). Lay the victim carefully down while protecting his or her head.

This can be done by lowering one arm so the head rests on it while lowering the victim to the deck. Another option is to have one rescuer release the upper arm and support the victim's head (See Figure 9.2.17)

Position the victim's head to one side. Move to the side of the victim, then move the victim's arm which is closest to you to a location above the head and on the deck. Grasp the victim's hip with one hand and shoulder with the other. Roll the victim toward you. Protect the victim's head during the turn so it does not fall onto the deck (See Figure 9.2.18).

After the victim is turned over, open the airway (Head-tilt/Chin Lift) and check for breathing. If not breathing, give two slow breaths and check the pulse. Perform a primary survey as learned in the American Red Cross Sport Safety Training Course.

## Conscious Victim on the Surface

There are many variables which must be considered if a victim is conscious and a rescue is needed. If a spinal injury is suspected, perform the rescue techniques discussed in Chapter 9.3. Determine if the victim needs assistance in swimming to the side of the pool. You must consider the type of accident which has occurred. Your rescue method will be modified to meet the demands of the injury. As was previously learned, there is a possibility of a variety of injuries including injuries to the upper and lower extremities, back, head, neck, face, abdomen, and chest. Rescue methods must be adapted to provide adequate support for the victim and allow the victim to eliminate movement of the injured body part. The following rescue techniques will allow the rescuer to modify the rescue in order to provide flotation and reduce or eliminate movement where necessary.



*Figure 9.2.14a. Supporting unconscious victim at side of pool*



*Figure 9.2.14b. Assistant on deck grasps victim's wrists*



*Figure 9.2.15 Rescuers grasp victim's wrists and upper arms*

Generally, the water is a good support for an injured extremity. The challenge occurs when the victim is removed from the water. This is where support and stabilization is important. The coach should try to identify what area of the victim's body has been injured. This can be determined by how the injury occurred and how the victim moves in the water after the accident. Sometimes it is fairly easy to determine which part of the victim is injured, but in some instances it is more difficult. In any situation where the extent of the injury is unknown, perform the rescue that will limit movement and provide the best support.



Figure 9.2.16 Lift the victim so the deck is at mid-thigh or lower

In situations where there is a head, neck, or back injury, the victim should be backboarded and removed from the water. Backboard procedures in deep water are discussed in chapter 9.3. If the injury involves upper or lower extremities, the following rescue procedures should be performed.



Figure 9.2.17 Protect the victim's head from the deck



Figure 9.2.18 Roll the victim to a supine position

### **Upper Extremity (shoulder, upper arm, elbow, lower arm, wrist, and hand)**

It must be understood that after a traumatic injury to an upper or lower extremity, divers may be dazed, disoriented, incoherent, and/or unable to move efficiently. They may struggle to stay at the surface or alternate between surfacing and submerging. They may be able to support themselves fairly well or they may have a great deal of difficulty staying afloat. If the victim is having difficulty swimming to the side of the pool, the coach should enter the water with a rescue tube as previously discussed. For your own protection, always keep the rescue tube between you and the victim. Since it would be beneficial to keep the injured extremity as motionless as possible, determine which body part is injured and **place the rescue tube under the armpit on the opposite side of the injury**. You may try to approach the victim from the front, grasp the rescue tube about in the middle with one hand and about 12 inches from the end with the other hand. With the rescue tube between you and the victim, push the short (12 inch) section under the victim's armpit, grasp his or her elbow, and hold the arm down and around the tube (See Figures 9.2.19, 9.2.20, and 9.2.21). **Hold onto the rescue tube and tow the victim to safety, letting the injured extremity drag behind.** This procedure will provide good flotation for the victim and allow him or her to avoid movement of the injured limb.



*Figure 9.2.19  
Rescue of a victim  
with an upper  
extremity injury*



*Figure 9.2.20  
Insert the rescue  
tube under the  
uninjured arm*



*Figure 9.2.21  
Trap the victim's  
arm over the  
rescue tube*



*Figure 9.2.22  
Rescue of a victim  
with a lower  
extremity injury*



### **Lower Extremity (hip, upper leg, knee, lower leg, ankle, foot)**

A diver with an injury to the lower extremity may be able to scull with the arms but may have difficulty kicking. Because of the resistance created by the water, any leg movement may be extremely painful.

Enter the water as previously described. **Approach the victim with the rescue tube in front of you. Extend the rescue tube to the victim. Instruct him or her to place the rescue tube against the chest and under the armpits. Grab the rescue tube and tow the victim to safety** (See Figure 9.2.22).

If the victim is unable to grab the rescue tube, place it against your chest and under your armpits. Swim to the rear of the victim and reach under his or her armpits. Support the victim in a comfortable position and swim to safety (See Figure 9.2.23).



*Figure 9.2.23  
Rescue of a  
victim with a  
lower extremity  
injury*

### **Conscious Victim Underwater**

Generally, the only time this would occur is if there was paralysis. In this case the rescuer should perform the Head-Splint in-line stabilization technique discussed in detail in chapter 9.3.

## REMOVAL OF THE VICTIM FROM THE WATER

After swimming the injured diver to the side of the pool, you must remove the diver from the water. Depending on the extent of the injury, assistance in exiting the water may or may not be necessary. Some questions to consider include:

- Will further movement of the injured part cause further damage?
- Could further injury result if you do not assist the diver in exiting the water?
- Would it be better to move to shallow water before exiting the pool?
- How much pain is the diver currently experiencing?
- What is the diver's level of consciousness?
- How many others are able to assist you?

There may be other considerations as well. The point is that there are many variables that will dictate your actions in removing the victim from the water. You may even decide that additional professional assistance is necessary. It may be prudent to allow EMS to perform the removal from the water.

Feedback from the injured diver may help you in deciding what you can do to assist. Once you tow the victim to the side of the pool, the diver will be floating with the assistance of a rescue tube. Perform a secondary survey to determine the extent of the injury. Ask the athlete questions relating to the injury, such as, Do you know what happened? Do you have pain anywhere? How much pain do you have? Do you feel light-headed? Are you nauseous? Can you feel your arms and legs? Can you move your arms and legs? Are you having difficulty breathing? Do you feel weak? Are you cold? The answers to these questions and others will help you decide how to approach and whether remove the victim from the water.

Whatever procedure may be used for removing the victim from the water, these guidelines should be followed:

- Call EMS
- Take charge or designate who is in charge.
- Protect yourself from blood-borne pathogens (see chapter 10.3).
- Provide support to eliminate movement of the injured extremity.
- Ensure that the extrication process will not cause further injury.
- Do not allow the victim to place any pressure or weight on the injured extremity.
- Work in unison with the victim and assistants.
- Give specific directions to others who may assist in the extrication.
- Identify a location for the victim following removal from the water. The location should be out of the sun, away from a crowd and close to the first aid facilities.

## Removal Procedure for Upper Extremity Injuries

**Transport the victim to a ladder in shallow or deep water.** Once you reach the ladder, the following actions should be taken:

- Instruct the victim to step onto the ladder with both feet and grab the ladder railing with the hand of the uninjured extremity.
- **Position yourself behind the victim, reach around the victim with both arms and grab the lip of the gutter or ladder** (See Figure 9.2.24).
- Squeeze your arms against the victim to stabilize the victim on the ladder.
- Position your chest close to or against the victim's back as you **climb up the ladder with the victim.**

Others on deck may assist with this extrication procedure by holding onto the victim to ensure safety. Assistants on deck may also help in stabilizing the injured part during the climb out of the water. Remember that any movement of the extremity may cause further injury.



*Figure 9.2.24 Upper extremity injuries-removal from the water*

## Removal Procedures for Lower Extremity Injuries

Extrication of a victim with a lower extremity injury could be complicated. It would be extremely difficult for the victim to climb the ladder without causing additional movement of the injured body part. Support must be given in a manner which restricts or completely eliminates movement of the extremity. The following procedure will assist in restricting movement and thereby make this process more comfortable for the victim:

- Stabilize the victim in the water at the side of the pool.
- Allow him or her to continue to hold onto the rescue tube or the pool edge.
- Retrieve a backboard and remove all straps and the head restraint.
- Turn the victim so his or her back is to the pool wall.
- One rescuer grabs the victim's right wrist and another grabs the victim's left wrist. The victim should also grab the rescuers' wrists (See Figure 9.2.25).
- **Position the backboard between the victim and the pool wall.**  
This can be done by a third rescuer or by the two holding the victim's wrists (See Figure 9.2.26).
- Guide the backboard, foot-end first, straight down into the water until its top end is adjacent to the victim's head (See Figure 9.2.27). Angling the foot-end of the board toward the pool wall will help in controlling the board while you submerge it.
- Pull the backboard and victim simultaneously up and onto the deck.
- As you pull the backboard onto the deck, rest the underside of the board against the edge of the pool and slide it onto the deck. This will make a smooth transport during the lift onto the deck (See Figure 9.2.28).

The backboard will have some buoyancy – some have a great deal. During this procedure, be certain that it is positioned squarely behind the victim before you slide the victim and board onto the deck. Other assistants in the water may help keep the backboard in position behind the victim. Make certain that the injured extremity will not slide off the backboard during the lift from the water.

*Figure 9.2.25  
Lower  
extremity  
injuries -  
removal from  
the water*



*Figure 9.2.26  
Positioning  
the backboard*



*Figure 9.2.27 Lifting the victim onto the deck*



*Figure 9.2.28 Laying the victim and backboard on the deck*

## **SUMMARY**

If a diver is injured during water entry, it may be necessary to perform a rescue. If at all possible, try to avoid entering the water yourself by providing an extension, reaching, or throwing assist. If the diver is unable to respond to this type of assistance, enter the water with a rescue tube and provide a flotation to protect the diver from further injury. This may be an extension of the rescue tube or pushing the rescue tube under the diver's armpit. If the diver is unconscious, a different method of rescue may be appropriate. Approach the unconscious diver from the side and turn the diver over onto the rescue tube. Once the diver is towed to the side of the pool, it may be necessary to assist the diver out of the water. In any removal of the diver from the water, it is important to eliminate movement of the injured body part as much as possible.

Proper rescue methods will allow the coach to provide support to the injured diver and remove the diver from the water. It is important for the coach to assess the situation before making contact with the diver in order to perform the appropriate rescue. Good preparation and judgment will provide for the safety of the rescuer and the diver.

## **REFERENCES**

American Red Cross (1995) Lifeguarding Today. St. Louis, MO: Mosby/Lifeline.

YMCA of the USA (1994) On the Guard II (Second Edition). Champaign, IL: Human Kinetics Publishers, Inc.

## Part 3. Spinal Injury Management

Because of the tragic life long consequences associated with quadriplegia, spinal injuries should be a concern for every coach. Although there are no recorded instances of catastrophic spinal injuries occurring in U.S. Diving practices or competitions, the potential for such an injury exists. Whenever a diver strikes his/her head, it must be assumed that a neck injury may be involved. The only way to rule out head and spine injuries is physical examination by a physician. The diver should be transported by ambulance while immobilized and should not be removed from the back board until examined and x-rayed by a physician. In this chapter you will learn how to:

- recognize a spinal injury,
- enter the water and approach a victim,
- perform the head-splint rescue providing in-line stabilization,
- use a backboard and cervical collar,
- remove a victim from the water, and
- provide emergency first aid.

### RECOGNIZING SPINAL INJURIES

There are several areas at a diving facility where the potential for a spinal injury exists. Injuries may occur on deck, in the water, on a trampoline or on any other dryland equipment. You should suspect a spinal injury anytime the victim:

- **is found unconscious such as at the base of a ladder, trampoline, portable landing pit or pool bottom;**
- **hits his or her head on the diving board, tower, pool bottom, or pool side;**
- **lands head-first on a trampoline or dryland apparatus;**
- **has struck his or her head after falling from a height greater than his or her own height;**
- complains of pain in the neck or back;
- cannot feel or move extremities.

In any of these instances, a serious injury to the spinal cord may have occurred. In order to grasp the significance of such an injury, it is important to understand the spine's structure.

### UNDERSTANDING THE SPINE

The spine is a strong, flexible series of bony structures that supports the head and trunk (see Figure 9.3.1). The bones of the spine (vertebrae) are circular in shape and are separated from each other by cushions of cartilage. This cartilage, called intervertebral disks, acts as a shock absorber when a person is walking, running or jumping. The spinal cord, a bundle of nerves that carries vital messages from the brain to be distributed to different parts of the body, runs through the hollow portion of the vertebrae. Nerve branches extend to the various parts of the body through openings on the sides of the vertebrae. The bony architecture of the spine protects the nerve center of the body from injury.

The spine is further divided into five regions. **The cervical spine refers to the area around the neck.** This region is the most susceptible to injury as a result of a competitive diving injury. The thoracic spine is located in the middle back, while the lumbar region is the lower back. The sacrum and coccyx, located at the base of the spinal column, complete the structure of the spine.

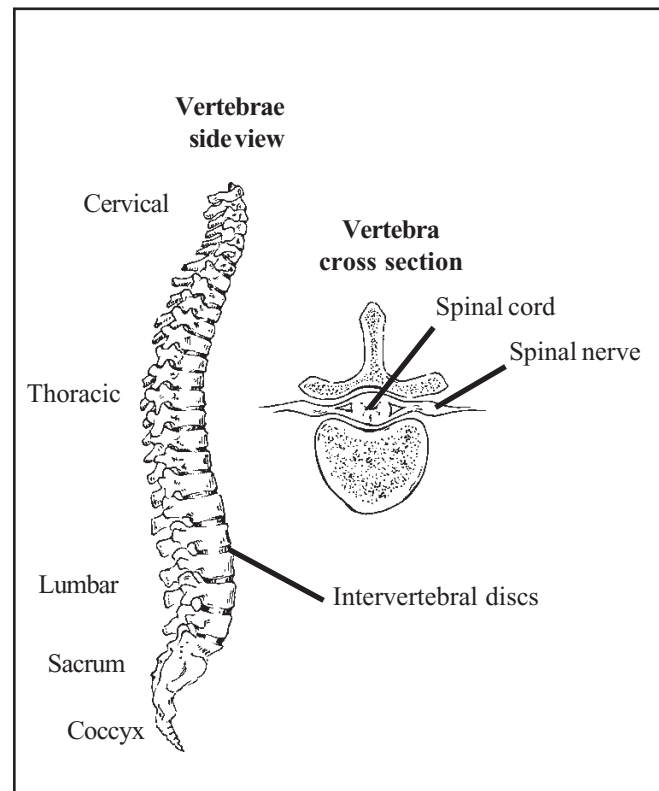

Figure 9.3.1 Spine side view and vertebra cross section

## Spinal Injury Management Flow Chart

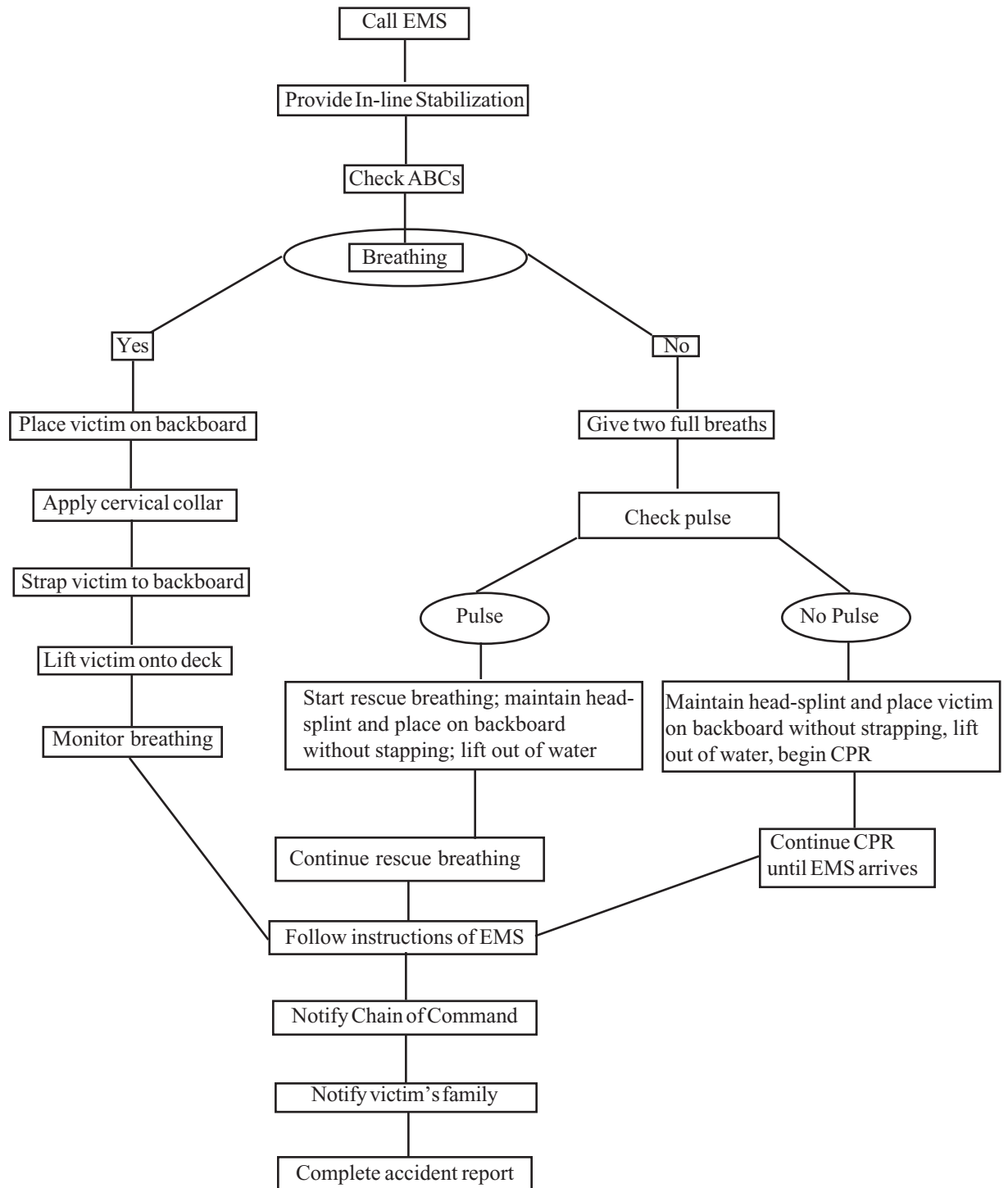

Figure 9.3.2 Spinal injury management flow chart

## SIGNS OF SPINAL INJURY

Acute injuries to the spine include fractures and dislocations of the vertebrae, sprained ligaments, and compressed or displaced intervertebral disks. Any of these injuries can cause injury to the spinal cord that may result in paralysis or death.

A victim of a spinal injury may exhibit any of the following signs:

- *Pain at the site of the injury*
- *Impaired movement in the extremities*
- *Loss of movement in the extremities*
- *Loss of movement below the site of the injury*
- *Loss of sensation or tingling in the extremities*
- *Deformity in the neck or back*
- *Visible bruising over an area of the spinal column*
- *Difficulty in breathing*

If you notice any of these signs, handle the victim as if he or she has a spinal injury.

The following are signs of a head injury and should also alert one that a spinal injury may have occurred:

- *Bleeding from the head*
- *Disorientation*
- *Fluid or blood in the ears and/or nose*

**It is commonly thought that a person with a spinal injury is completely paralyzed, yet this assumption is not necessarily true. A person with a spinal injury may be able to move his or her arms and legs. They may be able to struggle at the surface of the water or even swim to the side of the pool. In some instances they may climb out of the water and sit or stand on the deck.** Your ability to identify a situation where a spinal injury may have taken place could truly save a life.

## CONTACTING A SPINAL INJURY VICTIM

Just as in any rescue, proper rescue techniques are vital to assist a victim of a spinal cord injury. You must take special precautions to avoid causing additional harm. Spinal injuries are possible on deck or in the water. The victim may be standing, sitting or lying down following the injury. The diving coach must be prepared to handle all situations. It is difficult to determine the extent of a spinal cord injury. There have been situations in which an injured person has driven to a hospital, gone into the doctor's office and then has become paralyzed due to swelling caused by trauma to the neck. If

there is any possibility of a spinal injury, call EMS immediately. Proper steps in providing emergency care can eliminate further damage to the spinal cord. You will never be faulted for being too cautious (see Figure 9.3.2).

## BACK/HEAD/NECK INJURIES ON DECK

Follow the first aid steps for check, call and care listed in the American Red Cross Sport Safety Training Handbook on pages 68-71 for back or neck injury and 123-126 for head injury.

### Victim Standing or Sitting

If the injured diver is standing or sitting, perform the following steps:

- *Do not move the diver unless absolutely necessary.*
- *Maintain in-line stabilization to keep the diver's head and spine from moving. Keep the diver in this position until EMS Personnel arrive and take over.*
- *Maintain the victim's body temperature to minimize shock.*

### Victim in Lying Position

If the victim is in a lying position, perform the following steps:

- *Maintain the head and neck in the position in which they were found until EMS personnel arrive and take over.*
- *Maintain the victim's body temperature.*

If the victim is facedown and not breathing, the diver must be turned over. In that case,

- *Position one person at the victim's head.*
- *Position as many people as possible to one side of the diver.*
- *In unison, with as little movement to the spinal column as possible, carefully turn the diver to a supine position.*
- *Use the Modified Jaw Thrust for rescue breathing as described later in this chapter.*
- *Begin CPR if necessary.*

## INJURIES IN THE WATER

### Entering the Water

The rescuer must enter the water slowly and carefully. A waveless entry is required so that the movement of the water does not cause further injury. To effect a waveless entry, see page 151, Figure 9.2.10 A & B.

## Approaching the Victim

Regardless of whether you are in shallow or deep water, you must approach the victim slowly, carefully, and with as little disturbance of the water as possible. In deep water, use the breaststroke or a modified crawl stroke with an underwater arm recovery. Practice these approach techniques. Remember, they must help you to reach the victim quickly, without creating waves.

## Spinal Injury Rescue Techniques

Research has shown that the head-splint method, as described in this chapter, is the most effective method for stabilizing the head and neck during an in-water rescue. **In all situations where a spinal injury is suspected, EMS should be called immediately.**

## Head-Splint Rescue

The objective of the head-splint rescue (see Figure 9.3.3) is to stabilize the head and neck. It may be used if the victim is lying face down in the water before turning the victim over, or to stabilize a victim who is face up in the water. The in-line stabilization is accomplished by squeezing the victim's arms overhead to trap the head between them.



Figure 9.3.3 Head-splint rescue

## VICTIM IN PRONE POSITION (FACE DOWN) ON THE SURFACE OR UNDER WATER

Take the following steps to perform the head-splint rescue:

- Approach the victim from the side and stop while facing the victim's head.
- Grab the victim's right arm just above the elbow (upper arm) with your right hand.

- Grab the victim's left arm just above the elbow (upper arm) with your left hand.
- Move the arms sideways toward the head to a position in which the victim's upper arms cover his or her ears. This will center the victim's head between the arms.
- Simultaneously squeeze the arms against the head to trap it in position.

## Head-Splint Turn-Over

If a victim is found lying face down in the water, the head-splint should be applied in order to turn the victim to a face-up position (see Figure 9.3.4) **If the victim is under water, apply the Head-Splint and transport him or her to the surface. Tow the victim to the surface at a 45° angle, face down. At the surface, take the following steps to turn the victim:**

- Move the victim forward. The victim's legs will rise. Having the legs ride higher in the water will make it easier to turn the victim.
- As you roll the victim toward you, turn to face the victim's feet and legs.
- Avoid lifting the victim's arms out of the water during in-line stabilization.

## Keys to the Head-Splint Turn-Over

- Grab the upper arms near the elbows.
- Trap the head between the arms and maintain pressure.
- Move the victim forward.
- Roll the victim over to a supine (face up) position while submerging yourself to neck-depth water and turning to face the victim's feet.
- Victim's arms should be over your shoulder, next to your ear.

## VICTIM IN SUPINE POSITION (FACE UP)

Approach the victim from behind. Check to see if the victim is conscious. If conscious and floating on the surface, ask the following questions:

- Are you O.K.?
- What happened?
- Do you feel pain anywhere?
- Can you move your fingers?
- Can you move your toes?



Figure 9.3.4 Head-splint turn-over procedure

Responses to these questions will help the rescuer ascertain the condition of the victim. Let the victim know that you are now going to provide in-line stabilization to protect his/her spine. Explain exactly what you are going to do. Then proceed with the following:

Figure 9.3.5 Victim in supine position



•Treadwater behind the victim.

•Grab the victim's elbows in the same manner as previously learned (see Figure 9.3.5).

•Slowly and carefully move the victim's arms laterally (to the side) to a position which will allow you to trap the head between the arms.

•After the head is trapped, transport the victim to shallow water or to the side of the pool for backboarding.

## VICTIM ON THE BOTTOM IN DEEP WATER

If the victim is on the bottom in a face-up position, place your hands in position to perform the head-splint rescue. The victim's position may warrant improvising the Head-Splint technique. In any case, trap the victim's head between his/her arms and carefully lift the victim to the surface.

If the victim is in a face-down position, trap the head between the arms, lift the victim to the surface and then turn the victim over.

## Deep Water Rescues

Hitting the diving board, diving into another swimmer or striking the head on the pool bottom in the diving well are all possible ways a spinal injury may occur in deep water. In deep water, the head-splint technique should be used for in-line stabilization.

Stabilizing the neck in deep water is very difficult. In shallow water you do not need to support yourself as you work. In deep water, you need a strong kick to keep yourself in position to perform an effective rescue. A breaststroke, scissors, or rotary (egg-beater) kick should be used. The rotary kick is preferred because it provides a more stable transport of the victim.

It is also possible to use a rescue tube to support the victim while on the surface. Approach the victim with the rescue tube positioned under your armpits as in previously learned water rescues.

## Victim on the Surface

As with any spinal injury rescue in deep water, enter the water using a waveless entry. If a rescue tube is available, use it. If not, use a breaststroke or rotary kick. In either instance, use an underwater recovery of the arms to avoid disturbing the water while you approach the victim.

When you reach the victim, perform the head-splint rescue, including the turn-over if necessary, as described previously, and transport the victim to shallow water if possible. If you are at a pool or diving well with no shallow section, transport the victim to the side of the pool and perform the following sequence (see Figure 9.3.6):

- Instruct an additional person to lie down on the deck and verbally guide you toward the corner of the pool. The victim should end up perpendicular to the side of the pool.
- As you approach the side, the rescuer on the deck grasps the victim's upper arms and maintains in-line stabilization.
- **Once the rescuer on-deck has secured the victim's arms and head, the rescuer in the water should release the victim's arms and grab the pool gutter. Your role now is to support the victim's hips or lower back if necessary and then slide a rescue tube beneath the victim's knees.**
- **The victim is now ready to be placed on a backboard.** The backboarding procedure will be discussed later in this chapter.

## Victim Underwater

In most cases when the victim is submerged, he or she will not be flat on his or her back or abdomen on the bottom. Approach the victim from above or behind, depending on the victim's position on the bottom. Trap the victim's head using the head-splint technique described previously, and transport him or her to the surface with the face angled toward the bottom to avoid getting water up the victim's nose and potentially into the stomach and lungs. Once you reach the surface, turn the victim to a face-up position as previously described. Again, either transport the victim to shallow water, if possible, or to the side of the pool where you can get assistance.



Figure 9.3.6 Rescuer on deck provides head-splint in-line stabilization

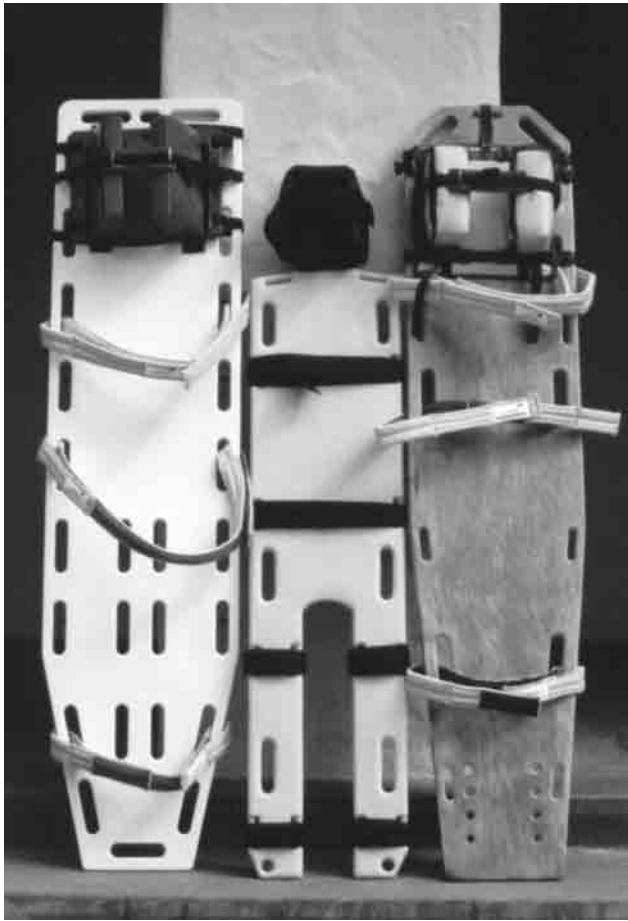

Figure 9.3.7 Backboards

## PLACING A VICTIM ON A BACKBOARD

Putting an individual with a spinal injury on a backboard is not a responsibility to be taken lightly. In many locales, paramedic units will request that you stabilize the victim in the water and allow them to backboard the victim. Check with the Emergency Medical Services System in your area to determine their protocol. Still, it is important for you to understand the equipment needed and the procedure used. You may be called upon to remove a victim from the water.

### Selecting a Backboard

There are a variety of backboards from which to choose as illustrated in Figure 9.3.7. Any of the pictured models is acceptable as long as it meets the following requirements.

#### **The backboard should:**

- be made of nonporous, lightweight resins or plastic;
- have slats or risers underneath the board or have hand grips which will help prevent rescuers from pinching their fingers when setting the board on the deck;
- have ample holes on each side of the board to adjust strap placement;
- have some form of head restraint attached to the board for immediate use (sand bags or rolled towels work well for stabilizing the victim's head if a manufactured restraint is not available).
- be long and wide enough to allow rescue of victims of varying sizes;
- have a minimum of 5 straps connected to the board (1 head strap, 1 chest straps, 1 waist strap, 1 knee strap, and 1 foot strap--a wrist strap is optional).

Padding should be available to place under the victim's head if necessary. Generally, there is a gap between the board and the victim's head once it is positioned on the board. The padding will prevent the head from dropping back onto the board or changing its alignment. Professional head-restraints include padding.

Backboards should be kept on-deck and ready for use at all times during diving practice or competition. All straps should be connected to the board or readily available for use.

# BACKBOARD

## Cervical Collar

Cervical collars, when applied correctly, will stabilize a victim's head and neck very effectively. There are several styles and sizes of collars available on the market. Two of the styles are illustrated in Figure 9.3.8.



Figure 9.3.8 Cervical collars

Not all cervical collars are appropriate for use in an aquatic environment. Consider the following in selecting cervical collars for your facility:

- Collars must be rigid. Some types of foam collars are ineffective in the water.
- You must have a variety of collar sizes available to meet the needs of individuals in your diving program. Adjustable collars work well and are available for purchase.
- One-piece collars are easier to apply than two-piece collars in aquatic backboarding procedures.

Cervical collars should always be stored with backboards. You may attach them to one of the backboard straps or place them in a bag and attach the bag to the board. In this way, the collars will always be available when and where you need them.

Most cervical collars have an opening in front of the larynx. This opening can be used to assist the rescuer in applying the collar. Place your middle finger inside the opening with all other fingers on the outside portion of the collar. Your thumb should be positioned on the opposite side from the fingers as illustrated in Figure 9.3.9. This will allow you to flex the collar for fitting it under the victim's chin.

Some collars can be slipped under the victim's neck and then bent to conform to his or her neck and chin. Other collars, which have preformed curves, need to be placed under the victim's chin and then slid under the neck. Regardless of which style of collar you may have, be careful in applying the collar to the victim. If the collar is the wrong size, remove it and try another size. Never try to force a collar into place!

This procedure takes a good deal of practice. Be sure you become skilled at it before your season starts. There may be restrictions related to applying cervical collars in your facility. Use procedures that conform to your state and local codes.



Figure 9.3.9 Hand position for applying cervical collar

### Sizing a Cervical Collar

An improperly sized cervical collar may cause further injury to the victim. It is important to note that the rigid collar is more of a reminder to the patient not to move the head than it is an actual immobilization device. Instruct the victim not to move his or her head and to answer questions with a verbal response rather than shaking or nodding the head. Be sure not to obstruct the airway with a too-small collar.

A cervical collar must be sized properly before applying it to the victim. The size will depend on the design of the collar being used. If the collar is either too loose or too tight, use the head restraints to immobilize the head. A collar that does not fit properly may do more harm than good.

Proper sizing includes the following steps:

- Place your fingers on the victim's neck under the corner of the jawbone to determine the height (distance in number of fingers) to the shoulder (See Figure 9.3.10).
- Size the collar to the same measurement as the victim's neck. Some collars have a black knob that fastens to the collar. Place your fingers beneath the knob and measure to the bottom of the plastic (not to the bottom of the foam cushion). If the distance is the same as the measurement of the victim's neck, the cervical collar is likely to be the correct size (See Figure 9.3.11).

If the collar does not have a black knob, measure the distance from the bottom of the chin cup to the bottom of the plastic. If sizing instructions come with the purchase of the collar, follow the manufacturer's directions.

### Applying a Cervical Collar

- Apply the device without interrupting manual stabilization.
- Slide the posterior portion of the collar under the victim's neck without lifting or moving the head or neck (See Figure 9.3.12).
- Wrap the anterior portion of the device around the front of the patient's neck and carefully attach the Velcro strap to make a snug fit. In some situations you may have to place the chin cup beneath the victim's chin and carefully slide the chin cup into place. Use the method for holding the collar, shown in Figure 9.3.9, for final placement of the collar.
- Do not overextend the victim's chin when applying the collar.

The victim's chin should rest comfortably in the device without moving the neck from the neutral position. The victim's head should not be able to turn from side to side or up and down. Be careful not to obstruct the victim's airway with the cervical collar.

# CERVICAL COLLAR



Figure 9.3.10 Measuring for correct cervical collar size



Figure 9.3.11 Measuring the cervical collar

## BACKBOARDING PROCEDURES

This section addresses how to:

- position the victim on the backboard
- strap the victim to the backboard; and
- lift the victim from the water.

Gutter and deck construction and the type of backboard you have may cause you to modify the procedures you use while backboarding. The rescuer on deck may have to adjust his or her position to allow the most effective in-line stabilization procedure. You may have to slightly alter the procedures that follow to make backboarding effective at your facility. It is vital that you develop procedures that fit your facility. Practicing rescue drills with members of the diving team, other supervisors or lifeguards is an effective way to establish and test those procedures.

Procedures will be introduced for both shallow and deep water. The following methods require at least two rescuers, but more assistants may be used. In all of the procedural descriptions that follow, Rescuer 1 is the rescuer in the water with control of the victim's head at the beginning of the procedure, while Rescuer 2 remains on deck and takes over in-line stabilization from the deck.

### Two Rescuer Procedure – Deep Water

This backboarding procedure requires two rescuers: Rescuer 1 in the water and Rescuer 2 on the deck. While Rescuer 1 maintains in-line stabilization and moves to a position perpendicular to the side of the pool, Rescuer 2 lays down on the deck in preparation for receiving the victim. Once Rescuer 1 is near the side of the pool, Rescuer 2 lies on the deck, grasps the victim's arms and applies pressure to trap the head (see Figure 9.3.6). Rescuer 1 releases the victim and Rescuer 2 maintains the victim in a horizontal position. It may be necessary to place a rescue tube under the victim's knees or have another person in the water to maintain him or her in the horizontal position (see Figure 9.3.13).

Rescuer 1 retrieves a backboard and prepares it for use. Rescuer 1 turns the backboard on edge as close to the victim as possible. The head-restraint pad should be in line with the victim's head. Rescuer 1 submerges the backboard and centers it under the victim (See Figure 9.3.14).



Figure 9.3.12 Positioning the collar

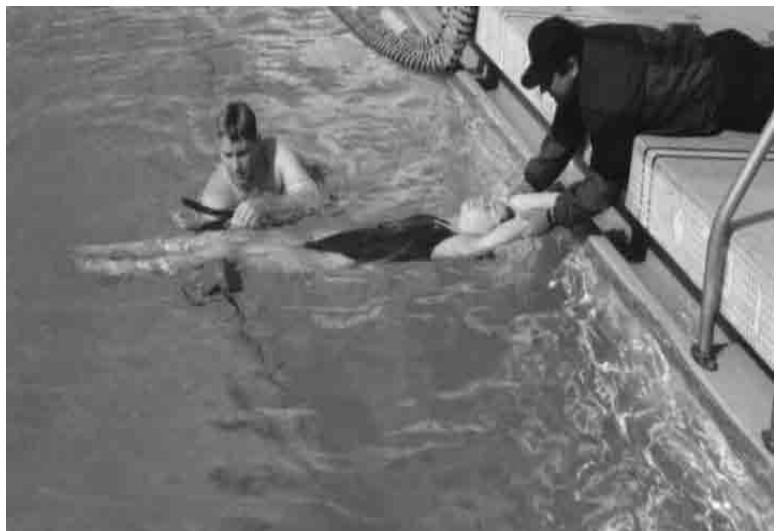

Figure 9.3.13 Rescue tube under victim's knees

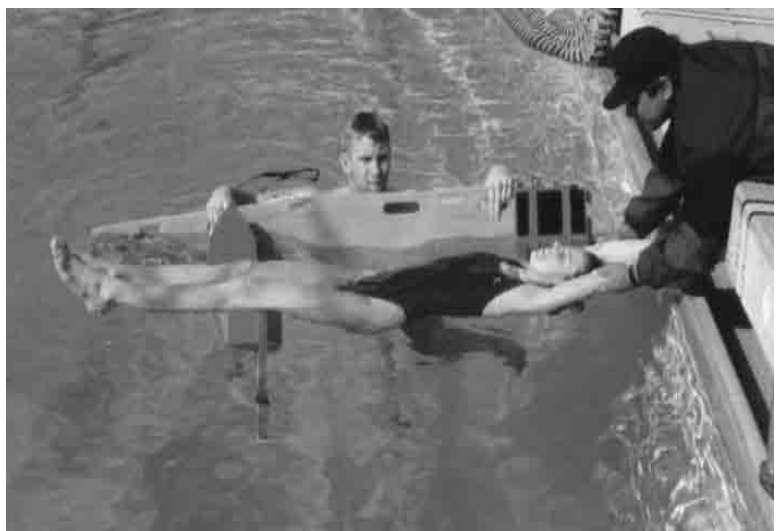

Figure 9.3.14 Positioning backboard on edge



Figure 9.3.15 Trapping the victim to the backboard



Figure 9.3.16 Rescuer on deck lifts backboard onto pool gutter



Figure 9.3.17 Rescuer on deck stabilizes victim on the backboard

Once the backboard is centered, Rescuer 1 allows the board to float up under the victim. Once the board comes up, Rescuer 1 places one arm on the victim's sternum (breastbone) and cups the victim's chin, fingers on one side and thumb on the other (See Figure 9.3.15). The other arm is placed under the backboard; the rescuer should then trap the victim on the board. Rescuer 2 lifts the top edge of the backboard onto the lip of the gutter (See Figure 9.3.16). Rescuer 1 grabs the side of the pool with the hand that was under the backboard and stabilizes the board on the pool gutter. Rescuer 2 lowers the victim's arms to his/her sides and then applies the cervical collar. Rescuers 1 and 2 may need alternately to stabilize the victim's head and neck and the backboard during application of the cervical collar. After the cervical collar is secure, Rescuer 2 grabs the victim's armpits and traps the victim's head between his or her arms (see figure 9.3.17). While trapping the victim's head, Rescuer 2 should apply pressure toward the side of the pool to assure that the backboard will not slip out of the gutter.

### Keys to Backboarding in Deep Water (2 Rescuers)

- Rescuer 1 moves the victim into position perpendicular to the side of the pool.
- Rescuer 2 lies on the deck and takes over in-line stabilization by grabbing the victim's arms and applying pressure against the head.
- Rescuer 1 releases the victim and places a rescue tube under the victim's knees or another assistant helps to maintain a horizontal position.
- Rescuer 1 retrieves the backboard.
- Rescuer 1 submerges the board and positions it under the victim.
- Rescuer 1 allows the board to float up to the victim.
- Rescuer 1 traps the victim to the board.
- Rescuer 2 lifts the edge of backboard onto the lip of the gutter, moves the victim's arms to the side and applies the cervical collar.



Figure 9.3.18a Chest Strap Secured Directly Under the Victim's Armpits



Figure 9.3.18b Securing the Foot Strap

### Securing the Victim to the Backboard (2 Rescuers)

**(Ed. Note: Regardless of whether a cervical collar is used in your facility, the victim's body should always be secured to the backboard before the head restraint (immobilizer) is secured. Whenever possible, follow the manufacturer's directions.)**

- Rescuer 2 grabs the victim's armpits and traps the victim's head between his or her arms while Rescuer 1 straps the victim to the backboard (see figure 9.3.18a).
- Rescuer 1 straps the victim's chest directly under the armpits.
- Rescuer 1 secures the waist strap around the waist and arms of the victim.
- Rescuer 1 removes the rescue tube from under the victim's knees and places it under the foot-end of the backboard.
- Rescuer 1 secures the knee strap.
- Rescuer 1 secures the foot strap. The foot strap should be placed in a "Figure 8" position (See Figure 9.3.18b).
- Rescuer 1 applies head restraints at each side of the victim's head; applies one restraint at a time. Rescuer 2 will need to move his or her arms from the side of the victim's head and reposition the arms on the outside of the restraints. Rescuer 2 should again apply gentle pressure toward the victim's head.
- Rescuer 1 applies the head strap.

## Removing the Victim from Deep Water

It is extremely important that the straps are snug around the victim. The chest strap is the most critical strap in the lift because it supports most of the victim's weight. This strap must be directly under the victim's armpits in order to hold the victim securely to the board during the lifting. Once the victim is secured properly to the backboard, the next step is to remove him or her from the water. Use additional assistance for this procedure if available. The number of assistants needed depends on the size and weight of the victim and the strength of those involved in the lift. Use common sense in deciding how many assistants are needed, but use at least two persons for the lift. After the victim is strapped to the board, Rescuer 2 removes the rescue tube and positions the board vertically against the pool wall (See Figure 9.3.19). Rescuer 1 (in the water) grabs the pool edge and assists in lifting the victim out of the water. On a count of 1, 2, 3, the rescuer on deck pulls up on the head section of the backboard while the person in the water lifts up on the foot-end of the board. Slide the backboard against the pool edge during the lift. Lay the backboard on the deck (See Figures 9.3.20). Rescuer 1 should lift with his or her legs (head up, shoulders over the knees and hips over the heels), not the back.



Figure 9.3.19 Victim in vertical position



Figure 9.3.20 Lift victim onto pool deck



## PROVIDING EMERGENCY FIRST AID



Figure 9.3.21 Modified jaw-thrust

A victim who can talk is conscious and breathing. There are situations in which the victim may require rescue breathing or CPR. In deep water while Rescuer 2 provides in-line stabilization from the deck, Rescuer 1 checks the ABCs: airway, breathing, and circulation. Begin by checking the victim's breathing. Look for the chest to rise and fall, and listen for breathing. If the victim is breathing, he or she will be circulating blood. If the victim is not breathing, give two full breaths and check for circulation. When the head-splint rescue is being performed, it may be difficult to feel a pulse in the neck (carotid pulse). In this case, the wrist (radial) pulse should be checked. If there is a pulse, begin rescue breathing. Because it is difficult to stabilize the spine and perform rescue breathing in the water, even with two rescuers, remove the victim from the water as soon as possible. If no pulse is felt, the victim must be positioned on a backboard and removed from the water. CPR should not be attempted in the water. In this case the Head-Splint should continue to be applied during removal from the water. Do not take the time to strap the victim to the backboard; CPR must begin immediately. If there is a shallow end of the diving area, rescuer 1 takes the victim to the shallow water. In shallow water, Rescuer 2 will need to check the victim's pulse because Rescuer 1 must maintain in-line stabilization.

### Rescue Breathing and CPR



Figure 9.3.22 Modified jaw-thrust with resuscitation mask

A resuscitation mask, rubber gloves and safety glasses should be used while performing rescue breathing and CPR. This equipment should be readily available for use in order to protect the rescuers. If the victim is bleeding, the rescuer should have protection against blood-borne pathogens. It is also possible that the victim will regurgitate during rescue breathing. A resuscitation mask with a one-way valve will shield the rescuer from contact with the victim's bodily fluids.

When giving rescue breathing, give one slow, full breath every 5 seconds for an adult; and one slow breath every 3 seconds for a child. Recheck the pulse and breathing about every minute. Continue rescue breathing as long as a pulse is present but the diver is not breathing. When giving CPR, give 15 compressions in about 10 seconds followed by 2 rescue breaths. Continue the 15-compressions/2 breaths cycle for about 1 minute (4 cycles). Recheck pulse and breathing. If there is no pulse, continue 15 compressions and 2 breaths until EMS personnel arrive. Check breathing and pulse every few minutes. If bones in the face may be broken or there is bleeding from the mouth which may result from dental injuries, modification to rescue breathing may need to be adopted. This may include mouth to nose rescue breathing in which the mouth is closed to keep the air from escaping.

### Modified Jaw-thrust Technique



Figure 9.3.23 Modified jaw-thrust with cervical collar in place

**In a suspected spinal injury, the victim's head should not be tilted back for performing the ABC's, rescue breathing or CPR.** This could cause further damage to the spinal column. In the modified jaw-thrust, the rescuer performing the ABC's, rescue breathing or CPR on the deck places his or her thumbs on the cheekbones of the victim as illustrated in Figure 9.3.21 when giving breaths. The right thumb is on the right cheek, the left thumb on the left cheek. The index and middle fingers of both hands should be positioned on the jawbone in a way that allows you to lift the jaw forward (you can feel the corner of the jawbone near the victim's ears). This action moves the tongue away from the back of the throat without tilting the head back. Light pressure on the cheekbones will help to maintain the victim's head in a neutral position. Once the jaw is moved forward, check for breathing. If the victim is not breathing, the rescuer must position the resuscitation mask over the victim's mouth and nose. Press down on the mask with your thumbs while pulling the jaw forward to open the airway (see Figure 9.3.22). Provide two full breaths and proceed to check the pulse. If you are not using a resuscitation mask, your cheek should be pressed against the victim's nose to keep the air from escaping. If a cervical collar has been applied and the victim then stops breathing, the rescue breather should carefully work his or her index and middle fingers down between the cervical collar and the victim's jaw in order to pull the jaw forward. If it is not possible to work the fingers into position for moving the victim's jaw forward, loosen the cervical collar and reposition your fingers (see Figure 9.3.23).

## Victim Regurgitation

If the victim vomits while the Head-Splint is being applied, rotate the victim to the side and have an assistant clear the mouth of foreign matter while you maintain in-line stabilization. If the victim vomits while strapped to the board, use the following procedure, illustrated in Figure 9.3.24, in the water or on the deck:

- One rescuer maintains in-line stabilization.
- Position at least two (preferably three) assistants on one side of the victim, with the strongest located at the victim's shoulders.
- Have each assistant reach across the victim and grab him or her. Be sure to grab the victim, not the board; grabbing the board will result in pinched fingers. The arm that crosses over the victim should be pressed against the victim to trap him or her against the board.
- Rescuer 1 coordinates the tilt by counting, "One, two, three, tilt."
- On the signal, the assistants lift up on the side of the backboard nearest to them until the victim is angled sideways on the board.
- Have an additional assistant clear the victim's mouth of vomit using a clean cloth or latex gloves to wipe it out.
- Lower the victim, on signal, to a flat position and continue to monitor breathing.

## Shallow Water Backboarding Procedures

If you have easy access to shallow water, it is easier to backboard a victim in the shallow section of the pool. If you have a strong rotary kick, swim the victim to the shallow end and then perform the same backboarding procedures as described previously for deep water backboarding.

### PRACTICE!

Spinal injury management skills must be practiced on a regular basis. Proper management makes a difference in the quality of life a suspected spinal injury victim may have in the future. It may also mean the difference between life and death.

All potential spinal injuries should be handled with the utmost care. Your training and practice of these skills are vital to the standard of care you provide the divers in your program.

## SUMMARY

Spinal injury victims in competitive diving are likely to be in deep water. They may be on the surface or underwater. They may be face-up or face-down. The coach must be proficient in procedures for stabilizing the head and neck, retrieving a victim from underwater, turning a spinal injury victim to a supine position, providing stable support at the surface, applying cervical collars, backboarding, and removing victims from the water.

Trauma to the head, neck, or back should be treated with utmost care. **Providing in-line stabilization will reduce the risk of further injury to the spinal column and may potentially**

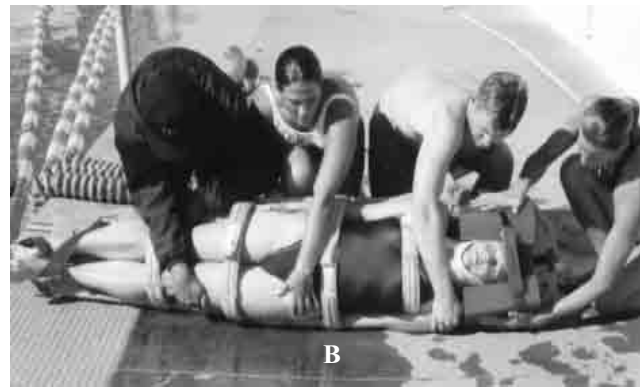

Figure 9.3.24 Clearing the Airway of a Victim Strapped to the Backboard

**prevent paralysis.** Having the appropriate equipment available for use and knowledge of how to use it will provide a safe and confident coaching and learning environment.

Proper equipment includes: a rescue tube, cervical collars in a variety of sizes, backboard, straps, and a head immobilizer. Practice of the procedures presented in this chapter (see Figure 9.3.25) is necessary in order to maximize efficiency and ensure the correct application of techniques.

## REFERENCES

- Kleiner, DM (1999) Inter-association guidelines for the appropriate care of spine injured athletes. In the National Youth Sports Safety Foundation: Sidelines 8 (4) 1-2.
- McSwain NE, White RD, Paturas JL, Metcalf WR (1997) The Basic EMT: Comprehensive Prehospital Patient Care. St. Louis, MO: Mosby/Lifeline.
- Stoy WA and the Center for Emergency Medicine (1996) Mosby's EMT-Basic Textbook. St. Louis, MO: Mosby/Lifeline.
- YMCA of the USA (1994) On the Guard II. Champaign, IL: Human Kinetics Publishers, Inc.

# **EMERGENCY**

## **SEQUENCE OF EVENTS**

- 1. Call EMS**
- 2. Provide In-line stabilization**
- 3. Check ABCs**
- 4. If breathing:**
  - *Place the victim on a backboard.*
  - *Apply a cervical collar.*
  - *Strap the victim to the board and lift onto the deck.*
- 5. If not breathing**
  - *Maintain Head-Splint*
  - *Give 2 full breaths*
  - *Check pulse*
    - if pulse, apply modified jaw thrust and start rescue breathing; maintain head splint and place victim on backboard without strapping, lift victim and backboard onto deck; continue rescue breathing*
    - if no pulse, maintain head splint and place victim on backboard without strapping, lift victim and backboard onto deck and begin CPR.*
- 6. When EMS arrives, follow their instructions.**
- 7. Notify the Chain of Command**
- 8. Notify Parents or Guardians**
- 9. Complete Accident Report Form**
- 10. Hospital Follow-up**

*Figure 9.3.25 Emergency sequence of events*



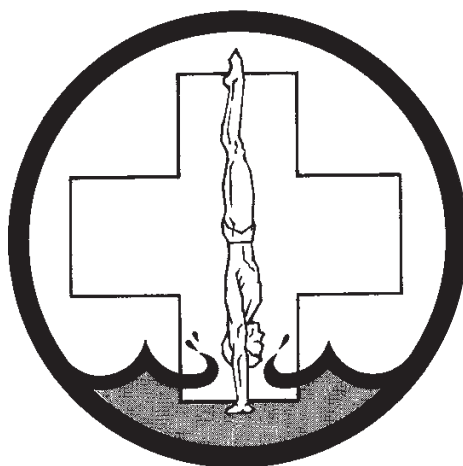

## **CHAPTER X**

# **FIRST AID CARE FOR INJURIES SPECIFIC TO COMPETITIVE DIVING**

by Gerald DeMers, Ph.D.

### **CHAPTER COMPETENCIES**

#### **Upon completion of this chapter, coaches should be able to:**

- Follow safety guidelines, procedures and risk management plans established by program administrators.
- Know their responsibilities in first aid and CPR.
- Execute the established emergency plan for the organization/activity/situation.
- Know first aid and CPR, or have immediate access to someone who is first aid/CPR qualified.
- Recognize and respond to symptoms of injuries that may occur in diving.
- Have a first aid kit available at all practices and competitions; know its contents and their appropriate use; know the location of the nearest telephone.
- Recognize the physical risks related to diving and how injuries may be controlled and the importance of reporting all symptoms immediately.
- Indicate where and when dangerous situations may arise and tell how these situations are to be managed.
- Apply standard management procedures designed to minimize exposure to blood-borne pathogens (BBPs).
- Follow specific procedures intended to limit exposure of divers, coaches and officials to blood or bodily fluids.
- Know when professional medical care is required for an injured diver.
- Provide unlimited fluid/water intake during physical activity and instruct divers about proper hydration and acclimatization.
- Recognize the differences of athlete's response to circulatory/respiratory stress.
- Know how such environmental factors as temperature, humidity and general climate can represent a risk to divers and how such risk can be reduced.
- Know how clothing worn for practice and competitions can affect the risks associated with various environmental conditions.

# Part 1. Life Threatening Emergencies

This chapter will focus on competitive diving injuries and their first aid care. For the sake of brevity the reader is directed to relevant sections in the [American Red Cross Sport Safety Training](#) (1997) texts. Since competitive diving involves the aquatic environment, in some cases, additional information will be given which will augment what is taught in the *Sport Safety Training* course.

## LIFE THREATENING EMERGENCIES

### SHOCK

#### *Definition of Shock*

Though shock is discussed in the [American Red Cross Sport Safety Handbook](#), it is worthwhile to review it here. Shock is the failure of the circulatory system to provide adequate oxygen-rich blood to all parts of the body triggering a series of responses that produce specific signals known as shock. These responses are the body's attempt to maintain adequate blood flow to the vital organs in order to prevent their failure.

#### *Cause*

With severe injuries involving great or rapid blood loss, the body may not be able to adjust adequately. Body cells do not receive enough oxygen, and shock occurs. Any significant fluid loss from the body, even from diarrhea or vomiting, may cause shock. Shock is a possibility with any injury.

Regardless of the cause, any significant decrease in body fluids affects the function of the heart. The heart will eventually fail to beat rhythmically. The pulse may become irregular or be absent altogether. With some irregular heart rhythms, blood does not circulate at all. When shock occurs, the body attempts to prioritize its needs for blood by ensuring adequate flow to the vital organs, such as the heart, brain, lungs, and kidneys. It does this by reducing the amount of blood circulating to the less important tissues of the arms, legs, and skin. This is why the skin of a person in shock appears pale and feels cool.

#### *Signs*

- *Restlessness or irritability*
- *Rapid and weak pulse*
- *Rapid breathing*
- *Pale or bluish, cool, moist skin*
- *Excessive thirst*
- *Nausea and vomiting*
- *Drowsiness or loss of consciousness*

#### *First Aid Care*

- *Monitor the ABCs, and provide care for any airway, breathing, or circulation problem you find.*
- *Help the victim rest comfortably.*
- *Help the victim maintain normal body temperature.*
- *Elevate the legs about 12 inches to keep blood circulating to the vital organs, unless you suspect head, neck, or back injuries, or possible broken bones involving the hips or legs.*
- *Do not give the victim anything to eat or drink, even though he or she is likely to be thirsty. The victim's condition maybe severe enough to require surgery, in which case it is better that the stomach be empty.*
- *Call EMS immediately. Shock cannot be managed effectively by first aid alone. A victim of shock requires advanced life support as soon as possible.*

#### *Prevention*

Shock may accompany any injury. You may prevent advanced symptoms of shock by following the first aid care noted above.

## BREATHING EMERGENCIES

#### *Definition of Breathing Emergencies*

A breathing emergency occurs when a diver is having difficulty breathing (respiratory distress) or cannot breathe (respiratory arrest). Breathing emergencies are life-threatening. Detailed information relating to breathing emergencies is located in [American Red Cross Sport Safety Training Workbook](#), pp. 14-17 and 21-24.

#### *Cause*

Divers with allergic reactions, chest injuries, or asthma have an increased likelihood of a breathing emergency. In competitive diving, the causes of respiratory distress or arrest may include:

- *obstructed airway*
- *injury to the chest or lungs*
- *electrocution*
- *allergic reaction*
- *respiratory conditions (asthma)*
- *aspirating water*

#### *Signs*

- *Difficulty breathing or gasping for air.*
- *Appearing to breathe faster or slower than normal.*
- *Breaths may be unusually deep or slow.*
- *May make unusual noises, such as wheezing or gurgling, or high-pitched sounds.*

- At first, the diver's skin may be unusually moist and appear flushed. Later, it may appear pale or bluish as the oxygen level in the blood falls.
- May feel dizzy or light-headed.
- May feel pain in the chest or tingling in the hands and feet. Any of these signals is a clue that the victim may be in respiratory distress.

#### First Aid Care

- Help the diver rest in a comfortable position. Usually sitting is more comfortable because it makes breathing easier.
- Try to reduce any anxiety which may contribute to the victim's difficulty in breathing.
- If it is available, assist the victim in taking his or her prescribed medication for the condition.
- Continue to monitor the diver. Respiratory distress may quickly change to respiratory arrest.
- Maintain body temperature.

#### Prevention

- An obstructed airway may be caused by divers eating food or chewing gum during practice or competition. Be certain they are not eating or chewing anything during the performance of a dive.

- Appropriate medication should be available at practice and competition for individuals with asthma or allergic reactions.
- Keep electrical appliances such as CD players away from the pool or spa.

#### Special Situations in Water

Recently questions have been raised about giving the Heimlich Maneuver in drownings. All lifeguard training courses agree upon using abdominal thrusts (Heimlich Maneuver) in drowning situations when the airway is blocked. Dr. Heimlich and some aquatic safety consultants also advocate using the maneuver to remove water from the lungs whether or not the airway is blocked. The concern by many doctors is that since water is generally ingested into the stomach, performing the Heimlich Maneuver when the airway is not blocked may cause the victim to vomit, in turn which could block the airway. Regardless of which procedure is followed at your facility, a blocked airway must be cleared in order to give rescue breathing or CPR.

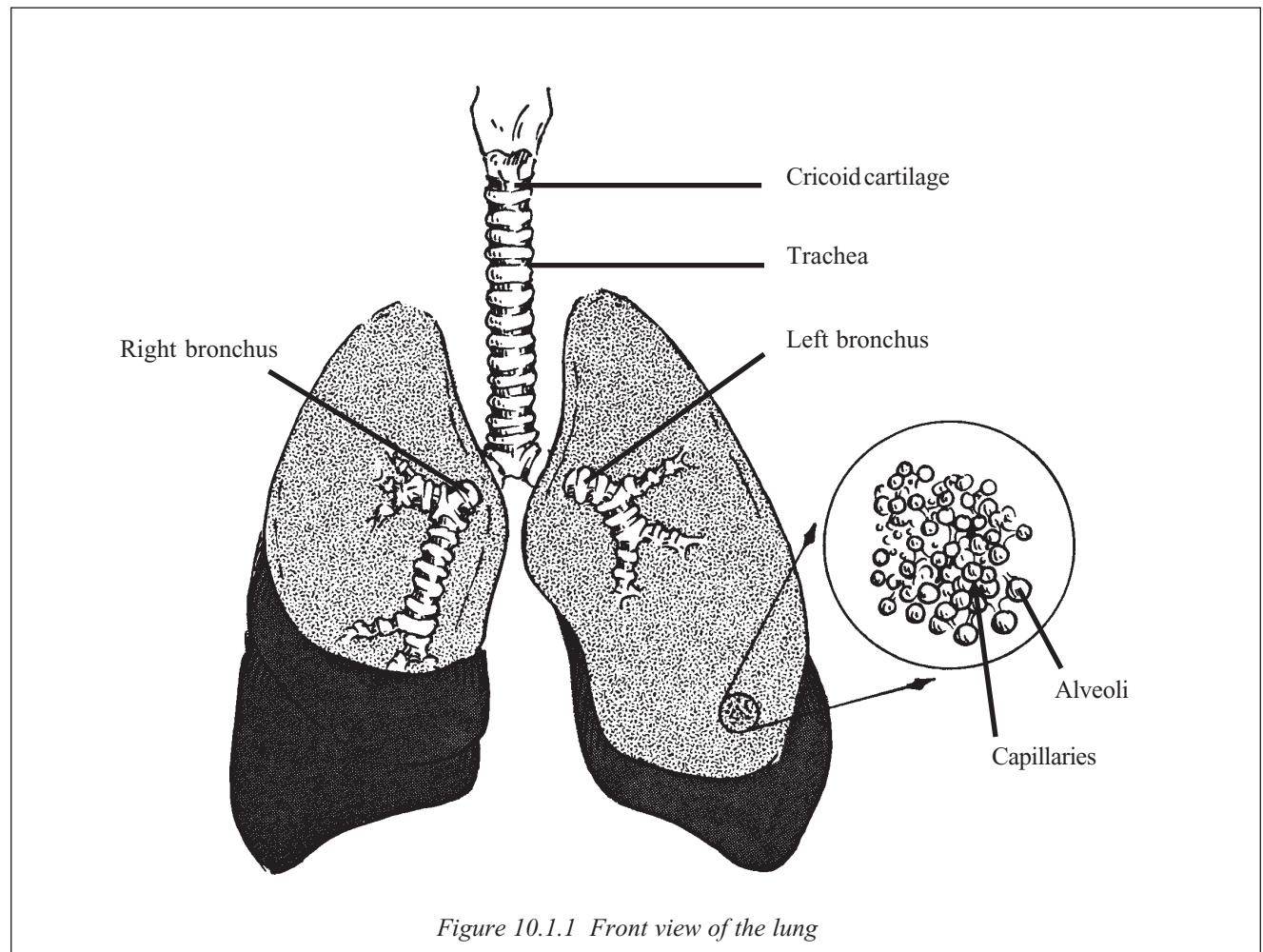

Figure 10.1.1 Front view of the lung

Fresh water aspirated into the lungs is absorbed rapidly by lung tissue. Water enters the lungs and is drawn through the membranes of the alveoli and into the blood because of an osmotic gradient. This blood dilution causes imbalances of sodium, potassium, chloride, magnesium, and other mineral salt components to occur. In eighty percent of freshwater drowning cases these imbalances contribute to spasms of the heart muscle called ventricular fibrillation, a precursor to cardiac arrest.

Fresh water in the lungs can also compromise air exchange. On the surface of every air sac (alveolus, see Figure 10.1.1) in the lungs is a chemical known as surfactant. Surfactant reduces surface tension in the alveoli and prevents these small air sacs from collapsing. In drowning, the water ingested into the lungs washes away the surfactant, causing air cell collapse, and making the exchange of gases more difficult. Because there are over 700 million alveoli in the lungs, many survive the wash-away and continue to help exchange gases as long as they are exposed to the air. Resuscitation of victims in this stage may be quite difficult because of the decreased exchange of oxygen and carbon dioxide. Also, as red blood cells absorb water in freshwater drowning, their ability to transport oxygen is significantly reduced.

## Laryngospasm

### *Definition of Laryngospasm*

**The epiglottis (flap that covers the trachea while swallowing) and the larynx have a reflex spasm, causing the victim to be unable to breathe.** This condition is not likely to occur in competitive diving; however, there is always this possibility in any water-activity.

### *Cause*

- *Aspirating vomit after a large meal.*
- *Being splashed in the face by water while trying to inhale.*

### *Signs*

- *Inability to breathe.*
- *Bluish color in the face due to lack of oxygen.*

### *First Aid Care*

- *Call EMS immediately and give rescue breathing.*

A blocked airway or the reduction of the body's ability to transport oxygen may result from the pathophysiology of the drowning process; therefore, it is important to seek medical attention for a diver who has been unconscious underwater for any period of time. A laryngospasm can occur up to 24 hours after a near drowning. Current EMS procedures recommend hospitalization for a near drowning victim.

### *Prevention*

- *Inform divers not to eat a big meal prior to practice or competition.*

## HEAD, NECK AND BACK INJURIES

Although U.S. Diving, the National Collegiate Athletic Association (NCAA) and the National Federation of State High School Associations (NFSHSA) report no record of a fatality or catastrophic injury connected to a supervised training session or diving competition in this country, such tragedies can and do occur. To date, there have been two known fatalities: Sergei Shalibashwili, a diver representing the former Soviet Union (*from what is today the Republic of Georgia*) was fatally injured while performing a 307c in the 1983 World Student Games in Edmonton, Canada; and Nathan Meade, an Australian diver, was fatally injured while practicing a 305c in Australia. Both divers struck their heads on the platform (Gabriel, 1992).

About half of the injuries in the U. S. Diving injury surveillance database reported in the 1993-1996 quadriennium involved the head, neck, and/or back. Head injuries account for about thirty percent and spinal (neck and back) injuries account for about twenty percent of U.S. Diving injuries. These injuries may occur from impact with the water, diving board or platform, and compression or twisting of the vertebrae. Occasionally facial injuries may occur. If there is any possibility the spinal column has been traumatized, follow the spinal injury management procedures, as listed in Chapter 9.3.

Trauma to the head, neck or back may include a variety of injuries. The following information will contribute to what is presented in the *American Red Cross Sport Safety Training* course and will address when to suspect head, neck, and back injuries; signs of head, neck, and back injuries; and general care for head, neck, and back injuries. See also pp. 66-67 of the [American Red Cross Sport Safety Training Workbook](#). First aid care for head, neck, and back injuries can be found on pages 123 for head injuries and page 68 for back or neck injuries in the [American Red Cross Sport Safety Training Handbook](#).

## Concussion

### *Definition of Concussion*

A concussion is an injury to the brain usually caused by an impact or rapid deceleration of the head. The brain is surrounded by a protective fluid (cerebrospinal fluid) and by membranes, and it is completely encased by bone. A sharp blow, however, can jar or shock the brain and cause injury (concussion). When the brain is so injured, it tends to swell. Because the space within the skull is limited, swelling may cause elevation of intracranial pressure. Elevated pressure may cause necrosis (cell death) to brain cells and may impair circulation. With significant intracranial bleeding, pressure elevation, and/or necrosis, death may ensue. Due to these fatal possibilities, coaches should exercise extreme caution whenever a head injury occurs. Concussions represent about five percent of all U.S. Diving injuries.

### *Cause*

Concussions in competitive diving generally result from the head hitting the platform or diving board and, in some instances, from the water. Such injuries are more likely to occur while performing dives in the inward and reverse groups.

## Signs

Knowledge of the circumstances surrounding an injury may be very helpful to a rescuer in making a judgment of concussion. Signs include:

- *Semiconscious, or unconscious.*
- *Able to speak, speech may be sluggish, slurred, or incoherent.*
- *Bump on the head or other indications of a blow to the head.*
- *Headache: mild to severe.*
- *Disorientation in regard to person, place, time, activity, or difficulty answering simple questions.*
- *Pupils of the eye dilated unequally.*
- *Behavioral/mood change; irrationality, agitation, lethargy.*
- *Loss of balance or coordination.*
- *Possible paralysis of legs or arms.*
- *Pulse varying from being full to slow, with heartbeat from weak to rapid.*
- *Eyes varying from unequal pupils to widely dilated to small in extreme cases.*
- *Convulsions, either general or local.*
- *Difficulty in speaking.*
- *Vomiting.*
- *Loss of bladder or bowel control.*

## First Aid Care

- **Call EMS immediately.**
- **The diver should be kept in a lying position.**
- **Do not give the victim water or food.**
- **Maintain body temperature.**

## Prevention

It is imperative for the diver to maintain a safe distance from the board or platform. Incorporate proper teaching progressions and safeguards to reduce the likelihood of this type of injury from occurring. Though this may help reduce the incidence of injuries, accidents of this sort are generally unforeseeable.

## Fractured Skull

### Definition of Fractured Skull

A broken or fractured skull may be open or closed. The skull is composed of eight bones, most of which are flat. Some are thick, others are very thin. Three major complications are associated with fractures of the skull:

- *Injury to the brain beneath the fracture (lacerations or compression).*
- *Hemorrhage from the open ends of the bone.*
- *Leakage of cerebrospinal fluid (CSF) to the outside of the body, if the fracture is open.*

**Blood or fluid leaking from the ears or nose after a suspected head injury may be an ominous sign.** It is important to note if the liquid is simply blood or if it has CSF mixed in with it. CSF is usually accompanied by blood. Blood leaks out of the nose or ears if the skull's bones are damaged.

## Cause

Fractured skulls rare in competitive diving. They represent less than .05% of all diving injuries. Impact with a platform (or possibly a diving board) is the usual cause of such an injury.

## Signs

- **Concussion**
- **Unusual behavior**
- **Unconsciousness**
- **Nausea or vomiting**
- **Blood from an ear**
- **Altered levels of consciousness**
- **Battle's Sign (a bruise behind one or both ears)**
- **Raccoon Eyes (black eyes)**

## First Aid Care

A fractured skull may be an open or closed wound. If it is an open wound, control the bleeding around the injury. Do not apply pressure directly over the wound.

- *Call EMS immediately.*
- *Maintain respiration and circulation.*
- *Do not attempt to stop bleeding and cerebrospinal fluid from draining from the nose or ears.*
- *Keep the victim lying down and quiet.*
- *Maintain body temperature.*
- *If the wound is on the back of the head, turn the victim on his or her side.*

## Prevention

See prevention for concussions.

## Facial Injuries

### Definition of Facial Injury

Fractured facial bones may lead to breathing difficulties. This condition may be life-threatening.

## Cause

There are relatively few occasions when a diver hits his or her face on the diving board or platform. About two percent of all U.S. Diving injuries involve facial injuries. The main danger of facial fractures is airway obstruction caused by bone fragments and blood.

## Signs

- *Common signs of a fractured or dislocated jaw may include irregularity of bite, loss of teeth, bleeding in the mouth, deformity and/or loose bone segments, increased salivation, and the inability to swallow or talk.*
- *Common signs of a fractured nose include bleeding, difficulty breathing, and/or displacement of the nose.*

## First Aid Care

- *Clear the airway of any obstructing materials such as teeth, blood or dentures.*

- If a spinal injury is not suspected, keep the victim lying on his or her side with the head tilted slightly to the side and toward the floor or deck if there is danger that blood flow will clog the breathing passages or get into the lungs.
- If the injury does not involve the eyeball, apply a sterile dressing and hold it in place with a firm bandage.
- Control bleeding by direct pressure but be gentle because there may be broken facial bones beneath the wounds.
- For cheek wounds, hold a gauze pad inside the cheek as well as outside if necessary. Do not put dressing in the mouth without holding it in place. Use gauze around your finger anytime you put your fingers in someone's mouth (they sometimes bite).
- For cut lips insert a rolled or folded dressing between the victim's lip and gum.
- Keep victim quiet and be very gentle so fracture areas will not displace or do further damage to other tissues.
- Maintain body temperature.

### **Prevention**

Same as for concussions.

## **Spinal Injuries**

### **Definition of Spinal Injury**

Trauma to the spinal column. The spine consists of small bones, vertebrae. The vertebrae are separated from each other by cushions of cartilage called disks. This cartilage acts as a shock absorber when a person walks, runs, or jumps. The spinal cord, a bundle of nerves, runs through the hollow part of the vertebrae. Nerve branches extend to various parts of the body through openings on the sides of the vertebrae. The spine is divided into five regions: the cervical (neck) region, the thoracic (mid-back) region, the lumbar (lower back) region, the sacrum (the lower part of the spine), and the coccyx (tailbone), the small triangular bone at the lower end of the spinal column. Injuries to the spinal column include fractures and dislocations of the vertebrae, sprained ligaments, and compression or displacement of the disks between the vertebrae.

### **Cause**

- A fall from a height greater than the victim's height.
- Any diving mishap in which the possibility exists that the person has struck or otherwise injured the head, neck, or back.
- Any injury involving a severe blunt force to the head or trunk.

### **Signs**

The signs associated with spinal injuries range from quadriplegia (dysfunction or paralysis of both arms and legs) and paraplegia (dysfunction or paralysis of the legs and lower parts of the body) to localized tenderness and pain. The diver's ability to walk should not determine whether the diver has a spinal injury. Fifteen to 20 percent of patients who required surgical repair of spinal injuries were found ambulatory (able to walk) on the scene by the arriving EMTs or they walked

into the emergency department at the hospital.

An unstable spine can be ruled out only by radiologic studies. The diving coach should not guess if a diver has a spinal injury. When in doubt, take appropriate precautions. In addition to the ability to walk, the ability to move extremities or feel sensation or the lack of pain to the spinal column also does not rule out the possibility of spinal column or cord damage.

The following signs most strongly suggest a spine injury, however there may be other signs which are subtle and variable:

- Tenderness in the areas of injury.
- Pain during movement of the head or neck.
- Pain independent of movement. This pain may be intermittent and is usually felt along the spinal column, arms, and/or in the lower legs.
- Any soft tissue injury noted to the head, neck, or back.
- Any loss of sensation, weakness, or paralysis.

### **First Aid Care**

General care for head, neck and back injuries can be located in the Sport Safety Training Workbook, pp. 66-67 and Handbook, pp. 68-70 & 123-126. Additional information is available in Chapter 9.3 of this text.

### **Prevention**

Since spinal injuries are most likely related to impact with a diving apparatus, follow spinal injury prevention strategies recommended on pages 114-115 and Dive Safe learn to dive progressions.

## **Internal Bleeding**

Internal injuries can occur through impact with diving apparatuses or impact with the water. Violent forces can cause severe soft tissue injuries involving large blood vessels and even organs deep within the body. These injuries can result in profuse internal bleeding. Internal bleeding can cause enough pressure on the nerves to result in blinding pain; extensive swelling can cut off blood circulation to a limb and cause tissue death. Hidden bleeding is difficult to diagnose.

### **Definition of Internal Bleeding**

Bleeding inside the body.

### **Cause**

Internal bleeding may arise from impact with the water, diving board or platform. Approximately three fourths of all U.S. Diving injuries result from impact with the water, diving board or platform.

### **Signs**

Initially, there may be no signs of internal bleeding. When the mechanism of injury indicates the possibility of internal damage and the signs of shock are present, internal bleeding should be suspected even if there is no obvious injury. In addition to the classic signs of shock, signs of internal bleeding include the following:

- Pain or tenderness where injury is suspected (may appear to be bruised).
- Bleeding from the mouth, rectum, or other orifice.
- Dizziness while at rest or when changing positions.
- Blood in the urine due to kidney contusion or laceration.
- Bright red, frothy blood coughed up.
- Vomiting of blood (can be bright red or dark red, resembling coffee grounds).
- Black, tar-like stools.
- Abdominal tenderness, rigidity, or spasms.
- Difficulty breathing due to fractured rib or air/blood in the chest cavity.

### **First Aid Care**

If you suspect internal bleeding, take the following steps:

- Summon EMS immediately.
- Lay the victim on a flat, level surface with knees bent.
- Establish and maintain an open airway, and treat for shock.
- Apply cold cloths or ice to the area where you think there is internal bleeding. If the bleeding is in an extremity, apply pressure to the injury site with a pressure dressing.
- Maintain body temperature until medical help arrives. If the person is lying on the pool deck, place a blanket or dry towel under him or her to help maintain body heat.
- Monitor pulse and respiration.
- Do not give the victim anything to eat or drink. Anticipate that the victim may vomit.

### **Seizures in the Water**

A seizure in the water can be serious. The airway opens and water will be allowed into the lungs causing major complications. Thus, anytime a diver has a seizure in the water, call EMS immediately.

#### **Definition of Seizure**

A disorder in the brain's electrical activity, marked by loss of consciousness and uncontrollable muscle spasms.

#### **Cause**

Posttraumatic seizures (convulsions) can occur from a head or spinal cord injury. Epileptic seizures can be triggered by various conditions or events, including hyperventilation,

trauma to the head or neck, physical stress, nervous tension, poor regulation of body temperature, lack of sleep, low blood sugar, illness, hormonal changes, fluid and electrolyte imbalances, alcohol, and bright or flashing light.

#### **Signs**

- Rigid muscles
- Jerky and convulsive movements
- Clenched teeth
- Drooling
- Loss of consciousness
- Loss of bowel and bladder control
- Biting of the tongue
- Periods of no breathing

#### **First Aid Care**

- Enter the water with a rescue tube. Place the rescue tube against your chest and under your armpits.
- Turn the victim to a supine (face up) position.
- Position yourself at the victim's head and place your hands on each side of his or her face. Hold the face out of the water** (See Figure 10.1.2).
- Move the victim away from the side of the pool so he or she will not hit it.
- Have others support the victim at the hips, if necessary, and maintain the victim in that position until jerky and convulsive movements stop.
- Place the victim on a backboard and lift him or her out of the water as described in Chapter 9.3 depending on the situation.
- Once on deck, monitor breathing and place padding under the victim's head. The head restraint on the backboard should already have protective padding.
- Protect the victim from further injury.
- If secretions are coming from the mouth, turn the victim onto his or her side with the head resting on the arm to allow the mouth to drain.
- Do Not** put anything in the mouth.
- Do Not** try to restrain the victim.



For more information concerning seizures on deck, see the [Sport Safety Training Handbook](#), pp. 160-161 and [Workbook](#), p.80.

Figure 10.1.2 Stabilizing a victim having a seizure

## HEAT EXHAUSTION--HEAT STROKE

### Heat Exhaustion

#### *Definition of Heat Exhaustion*

Heat exhaustion is the early stage and the most common form of heat-related illness. It typically occurs after long periods of strenuous exercise or work in a hot/humid environment. Heat exhaustion is an early indication that the body's temperature-regulating mechanism is becoming overwhelmed. It is not always preceded by heat cramps. Over time, the victim loses fluid through sweating, which decreases the blood volume. Blood flow to the skin increases, reducing blood flow to the vital organs. Because the circulatory system is affected, the person may be light-headed, nauseous or hypotensive (low blood pressure).

If heat exhaustion is allowed to progress, body temperature will begin to climb and sweating may decrease. A victim may vomit and begin to show changes in his or her level of consciousness. Without prompt care, heat exhaustion can quickly advance to a more serious and potentially fatal form of heat-related illness--heat stroke.

#### **Cause**

Substantial loss of body fluids can cause heat exhaustion. Loss of bodily fluids result from:

- *Exercising in hot/humid conditions.*
- *Prolonged submersion in a spa (with water temperature greater than 100° F).*
- *Prolonged exposure to environmental conditions in a sauna or steam room.*

#### **Signs**

- *Normal or below normal body temperature (a thermometer should be kept in the first aid kit).*
- *Cool, moist, pale skin. (Skin may be red in the early stage, immediately following exertion)*
- *Headache.*
- *Nausea.*
- *Dizziness and weakness.*
- *Exhaustion.*

#### **First Aid Care**

In its early stage, heat exhaustion can usually be reversed with prompt care.

- *Often the victim feels better when he or she rests in a cool place and drinks cool water.*

#### **Prevention**

- *Drink ample fluids before and during strenuous exercise.*
- *Limit time spent in a spa, sauna, or steam room.*
- *Loss of body fluids is directly related to temperature and amount of time spent in a warm/humid environment.*

### Heat Stroke

#### *Definition of Heat Stroke*

Heat stroke is the least common but most severe heat-related illness. Heat stroke occurs when the body systems are

overwhelmed by heat and begin to stop functioning. Sweating stops because body fluid levels are low. When sweating stops, the body cannot cool itself effectively, and body temperature rapidly rises. It soon reaches a level at which the brain and other vital organs, such as the heart and kidneys, begin to fail. If the body is not cooled, convulsions, coma, and death will result. Heat stroke is a serious medical emergency.

#### **Cause**

Same as heat exhaustion: the loss of bodily fluids.

#### **Signs**

- *High body temperature (often as high as 106 degrees F).*
- *Red, hot, dry skin.*
- *Progressive loss of consciousness.*
- *Rapid, weak pulse.*
- *Rapid, shallow breathing*

#### **First Aid Care**

- *Call EMS immediately. It is difficult if not impossible to treat heat stroke in the field. The victim needs to be transported to a hospital as soon as possible.*
- *Cool the body by any means available.*
- *Give fluids if conscious.*

## REFERENCES

American Red Cross (1997) Sport Safety Training Handbook, St. Louis, MO: Mosby/Lifeline.

American Red Cross (1997) Sport Safety Training Workbook, St. Louis, MO: Mosby/Lifeline.

American Red Cross (1996) First Aid: Responding to Emergencies, St. Louis, MO: Mosby/Lifeline.

Arnheim D (1989) Modern Principles of Athletic Training, St. Louis, MO: Times/Mirror/Mosby College Publishing.

Booher J, Thibodeau G (1985) Athletic Injury Assessment. St. Louis. MO: Times/Mirror/Mosby College Publishing.

Clarke KS (1997) U.S. Diving Injury Surveillance Database 1993-1996 Quadrennium Report. In U.S. Diving Coach Development Reference Text (in progress).

Golden D, Miller DI (1990) Biomechanics of safe diving. In Gabriel JL, George GS (eds.) U.S. Diving Safety Manual. Indianapolis, IN: U.S. Diving Publications, p.132.

Gallaspy J, May J (1996) Signs and Symptoms of Athletic Injuries, St. Louis, MO: Mosby.

YMCA of the USA (1994) On the Guard II ( Second Edition). Champaign, IL: Human Kinetics Publishers, Inc., p.63.

## Part 2. Non-Life Threatening Emergencies

### SOFT TISSUE INJURIES

Soft tissue injuries are addressed in the American Red Cross Sport Safety Training program. Information can be found on pp. 85-88 in the American Red Cross Sport Safety Training Handbook and pp. 48-53 of the Workbook.

Any injury to the soft tissues is called a wound. Soft tissue injuries are typically classified as either closed or open wounds. A wound is termed “closed” when the soft tissue damage occurs beneath the surface of the skin, leaving the outer layer intact. A wound is “open” if there is a break in the skin’s outer layer. Open wounds usually result in external bleeding. Approximately one-third of all U.S. Diving injuries result in some type of wound.

### CLOSED WOUND

The simplest **closed wound** is a bruise, also called a contusion. Bruises result when the body is subjected to a blunt force, such as a flat impact with the water. This usually results in damage to soft tissue layers and blood vessels beneath the skin. When blood and other fluids seep into the surrounding tissues, the area discolors and swells. The amount of discoloration and swelling varies depending on the severity of the injury. At first, the area may only appear red. Over time, more blood may leak into the area, making the area appear dark red or purple.

### OPEN WOUND

**Open wounds** are injuries that break the skin. These breaks can be as minor as a scrape of the surface layers or as severe as a deep penetration. Any break in the skin provides an entry point for disease-producing microorganisms. There are three main types of open wounds which may occur in diving injuries:

- *Abrasions*
- *Lacerations*
- *Avulsions*

Because of the potential of microorganisms being harbored in untreated water, it is extremely important that the swimming pool purification and filtration systems work properly. If either is not operating, microorganisms will have direct access to the bloodstream of the diver with an open wound. Maintain a chlorine residual of at least 1.0 parts per million and a pH of 7.5. The filtration system should have the capacity to filter all of the water in the pool four times over a 24 hour period.

### Definitions of Types of Wounds

#### *Abrasions*

An abrasion is the most common type of open wound for divers. Contact with the non-slip surfaces of diving boards and platforms may result in abrasions such as when a diver stubs his/her toe. Because an abrasion exposes sensitive nerve endings, it is usually painful. Bleeding is easily controlled and not severe, since only the capillaries are affected.

#### *Lacerations*

A laceration is a cut. Deep lacerations can affect the layers of fat and muscle, damaging both nerves and blood vessels. Lacerations usually bleed freely and, depending on the structures involved, may bleed profusely. Because the nerves may also be injured, lacerations are not always immediately painful.

#### *Avulsion*

An avulsion is an injury in which a portion of the skin and sometimes other soft tissue is partially or completely torn away. A partially avulsed piece of skin may remain attached but hangs like a flap. Bleeding is usually significant because avulsions often involve deeper soft tissue layers.

#### *Causes*

Wounds in competitive diving are a result of impact with diving apparatuses, water, or pool structure.

#### *Signs*

- *Bleeding*
- *Reddish color to the skin*
- *Bruising*
- *Swelling*
- *Pain*

### First Aid Care for Closed Wounds

- *Direct pressure on the area decreases bleeding beneath the skin.*
- *Elevating the injured part helps to control bleeding and reduce swelling.*
- *Cold packs can be effective in helping to control both pain and swelling.*
- *When applying ice or a chemical cold pack, protect the skin by placing a gauze pad, towel, or other cloth between it and the ice.*

## First Aid Care for Open Wounds

- Put on latex gloves.
- Use some form of eye shield.
- Apply direct pressure with a sterile dressing over the wound.
- If a sterile dressing is not available, use a towel.
- Summon more advanced medical care as indicated.
- Use a pressure point to control bleeding if necessary.
- Wash your hands immediately after completing care, even if you wore gloves.
- Additional information relating to caring for soft tissue injuries is located in the American Red Cross Sport Safety Training texts as mentioned previously.

## Stitches

It can be difficult to judge when a wound should be seen by a doctor for stitches. A quick rule of thumb is that stitches are needed when the edges of skin do not fall together or when the wound is more than an inch long. Stitches speed the healing process and improve the look of scars. The wound should be stitched within the first few hours following the injury. In the event of a head laceration resulting from hitting the board, be advised to alert the physician to check for paint chips that might be embedded. The following major injuries may require stitches:

- Bleeding from an artery, or uncontrollable bleeding,
- Deep cuts or avulsions that show the muscle or bone, or involve joints near the hands or feet,
- Large or deep punctures,
- Large or deeply imbedded object, and
- Wounds that, if left unattended, could leave a conspicuous scar, such as those that involve the lip or eyebrow.

Consult with a minor diver's parent/guardians and/or physician if you are at all in doubt as to the need for stitches.

## Scalping

### Definition of Scalping

A part of the scalp is partially or completely detached from the skull.

### Cause

A diver hitting the end of the diving board or platform with his or her head in a way that peels part of the scalp back or separates it from the skull may cause scalping. This type of injury is possible with any head injury resulting from contact with the diving board or platform. Approximately ten percent of all U.S. Diving injuries result in head wounds. Scalping is an extremely rare occurrence.

### Signs

It may be difficult to determine the extent of the injury to a diver's scalp because of the profuse bleeding that generally accompanies a scalp wound. The diver's hair may also mask the extent of the injury.

- Bleeding from the scalp.
- Flap of scalp partially or completely detached.

## First Aid Care

- Remove the victim from the water.
- Flaps of skin or scalp may be gently folded back to their normal position before bandaging.
- Control the bleeding with bulky pressure bandages.
- If a piece of scalp is completely detached, wrap it in a sterile dressing and place it in a plastic bag. Place the plastic bag on ice and transport the piece of scalp with the diver to the hospital.

## MUSCULOSKELETAL INJURIES

Information relating to musculoskeletal injuries is located in American Red Cross Sport Safety Training Handbook, pp. 88-89, 93-94, 137-140, and 152-155; and American Red Cross Sport Safety Training Workbook, pp. 62-77.

The types of musculoskeletal injuries occurring in the sport of diving include: ligament sprains; muscle strains; dislocations; and broken bones.

## Strains and Sprains

### Definition of Strain

A strain is a pull or tear to a muscle or tendon. Strains are characterized by pain upon stretching or contraction of the injured muscle/tendon.

### Definition of Sprain

A sprain is the stretching or tearing of ligaments. Since ligaments provide support and stability for joints, sprains occur when a joint is forced beyond its normal range of motion. The more ligaments that are torn, the more severe the injury. The severity of injury depends on the degree of ligament disruption (partial versus complete tear), and the degree of instability of the joint. Severe sprains may also involve a fracture of the bones that form the joint.

Mild sprains, which only stretch ligament fibers but do not result in significant joint laxity, generally heal quickly. However, the speed of healing also depends on which joint is injured, and the demands placed on the joint. The victim may have only a brief period of pain or discomfort and quickly return to activity with little or no soreness. For this reason, people often neglect sprains, and the joint is often re-injured. Pain following an injury does not always correlate with functional impairment. A diver with an ankle sprain may have minimal pain but still have significant laxity of ligaments, proprioceptive deficits, general deconditioning and a high risk of re-injury. The absence of pain does not equal absence of dysfunction. Severe sprains or sprains that involve a fracture usually cause pain when the joint is moved or used.

Often, a sprain is more disabling than a fracture. When fractures heal, they usually leave the bone as strong as it was before. It is unlikely that another break will occur at the same spot. On the other hand, once ligaments become stretched or torn, the joint may become less stable if the injury does not receive proper care. A less stable joint makes the injured area more susceptible to re-injury.

## Causes of Strains and Sprains

Sprains and strains account for approximately forty percent of all U.S. Diving injuries. They are caused by a variety of circumstances where the muscle, joint, tendon, or ligament is overstretched. Acute muscle strains in the shoulder most commonly involve the triceps. The triceps are stretched and contracted during water entries and “swims.” A partial strain or complete tear can be disabling to a diver. Such injuries require special care. Shoulder strains occur mainly as the result of a violent pull to the arm, an abnormal rotation, or a fall on the outstretched arm which results in tearing or even rupturing tendinous tissue.

### *Signs of Strains and Sprains*

Pain, swelling, inability to use the part, and/or deformity between the joints.

### *Care for Strains and Sprains*

When a person twists an ankle or strains his or her back, the tissues underneath the skin are injured. Blood and fluids seep out from the torn blood vessels and cause swelling at the site of the injury. Muscles spasm to protect the injured area. This often causes more pain. By keeping the injured area cool, one controls internal bleeding and reduce pain. Cold causes the broken blood vessels to constrict, reducing the blood and fluid that seep out. Cold reduces pain by numbing the nerve endings, thereby reducing painful muscle spasms.

It is difficult to determine if an injury is a sprain or a broken bone. The only way to find out is by x-ray. A physician will most likely advise applying ice to the injury as long as there is inflammation and pain. Heat plays a role only with chronic injuries. The heat may be useful to improve soft tissue or joint mobility prior to exercise. If you are unsure of whether to use cold or heat on an injured area, always apply cold until you can consult with a physician.

## Rotator Cuff Injuries

Muscles in the shoulder receive significant impact from water entries. Continual and repetitive training may result in a rotator cuff impingement. See page 124 for a discussion of this injury.

### *Definition of Rotator Cuff Injury*

Such injuries involve one or more of the following shoulder muscles: Supraspinatus, infraspinatus, teres minor, and subscapularis.

### *Cause*

A rotator cuff impingement occurs from chronic microtrauma involving compression and tension on the rotator cuff. Repetitive overhead activity in combination with strength deficiencies in the rotator cuff and instability of the shoulder joint combine to cause tendonitis or even degenerative tears of the rotator cuff.

### *Signs*

- shoulder pain with overhead activity
- *aching after activity; often felt over anterior shoulder or deltoid*

Coaches should advise divers displaying early symptoms of shoulder impingement to see an orthopedic specialist for proper care and treatment.

### *Conservative Treatment*

Conservative treatment recommended by the physician might include:

- Cold Application: Athletes experiencing shoulder pain and inflammation may benefit from cold application after workouts. This may take the form of ice massage or an ice chip pack.
- Heat: Heat of any form should be avoided after workouts. However, heat may be beneficial before workouts or at other times.
- The physician may prescribe an oral antiinflammatory drug for a short period of time. Coaches should not recommend use of drugs, even nonprescription, without checking with a physician first.
- Rest: A change of activity, or complete rest may be warranted.

### *Prevention*

- Appropriate strength in the rotator cuff and scapular stabilizing musculature.
- Proper stretching and warm-up prior to practice or competition.
- Proper body alignment for entries.

## Muscle Spasms

### *Definition of Muscle Spasm*

A reflex reaction caused by impact or tension on a muscle is commonly called a “spasm.”

### *Cause*

Muscle spasms may result from impact with the diving apparatus or surface of the water.

### *Signs*

Mild to severe contraction of the muscle.

## Dislocations

### *Definition of Dislocation*

A dislocation is a displacement or separation of a bone from its normal position at a joint.

### *Cause*

Dislocations are usually caused by severe forces on a joint. They result from forces causing the joint to go beyond its normal anatomical limits. Subluxations are partial dislocations in which the joint goes beyond its normal limits but stops short of a complete dislocation. Common areas of dislocation in divers include the shoulder, the patella, and the fingers or thumb.

### **Signs**

Several factors are important in recognizing and evaluating dislocations:

- *Deformity is almost always apparent. Comparison of the injured side with its counterpart often reveals distortions.*
- *There is loss of limb function.*
- *Swelling and point tenderness are immediately present.*
- *There may be loss of pulse or sensation in the affected part.*

Dislocations or subluxations may result in a rupture of the stabilizing ligamentous and tendinous tissues surrounding the joint, and avulsion or pulling away from the bone. Because dislocations injure the stabilizing structures of a joint, recurrent dislocations become more likely.

A first-time dislocation or dislocation in a skeletally immature diver (open growth plates) should always cause one to suspect an associated fracture. Before transporting the diver to a physician, the injury should be properly splinted and supported to prevent any further damage. **Do not try to put the joint back together.** This can cause additional injury if done improperly.

### **Fracture**

#### **Definition of Fracture**

A fracture is a break or disruption in bone tissue. A compound fracture is a broken bone in conjunction with disruption of the surrounding skin and soft tissues. Such injuries allow direct communication between the fractured and the unsterile outside world. Try to control the bleeding by exerting pressure proximal (around the periphery) to the injury. Do not apply pressure directly over the injury. Because of the magnitude of bony and soft tissue injury and because of the high risk of infection, most compound fractures require in-hospital surgical treatment by an orthopedic specialist.

#### **Cause**

The causes of a fracture in competitive diving are impact with the diving board, platform, or other diving apparatuses. Approximately one-fifth of all U.S. Diving injuries result in a fracture. Location of the fractures include the head, face, neck, upper extremities, torso and lower extremities.

### **Signs**

There are telltale signs such as an open wound with a protruding bone and or a severely deformed body part. However, fractures can be subtle and hard to detect.

### **General Care for Musculoskeletal Injuries**

When you find a musculoskeletal injury, immediately summon more advanced medical personnel if:

- *The injury involves severe bleeding.*
- *The injury involves the head, neck or back.*
- *The injury impairs walking or breathing.*
- *You see or suspect multiple musculoskeletal injuries.*

Of major importance in musculoskeletal injuries is the initial control of hemorrhage, early inflammation, muscle spasm, and pain. The acronym for this process of care is **PRICE**:

#### **PROTECT**

#### **REST**

#### **ICE**

#### **COMPRESSION**

#### **ELEVATION**

#### **Protect**

Providing support to the injured body part will reduce or eliminate unwanted movement. This will assist in preventing further injury and promote the healing process.

If you suspect a serious musculoskeletal injury, you must immobilize the injured part before giving additional care such as applying ice or elevating the injured part. In most situations, EMS is only minutes away, so rather than splint the injured part, wait for EMS to arrive. They have the necessary equipment for proper splinting. Stabilize the part in the position you find it while waiting for EMS to arrive. Keep the diver warm with towels or a blanket. Treat for shock. Keep the diver as comfortable as possible. Check for severe bleeding.

Do not try to straighten a deformed limb. This could lead to further injury of soft tissue, bone or nerves.

#### **Rest**

Rest is many times an overlooked necessity for rehabilitation of musculoskeletal injuries. It serves a very important function in the recovery process. Rest is essential for musculoskeletal injuries, and can be achieved by not moving the part or can be guaranteed by the application of tape, wraps, splints, casts, and the assistance of a cane or crutches. Immobilization of an injury for the first 2 or 3 days after injury helps to ensure healing of the wound without complication. In some cases early movement increases hemorrhage, disrupts healing and ultimately prolongs recovering.

#### **Ice (cold application)**

Ice is an effective first aid agent and cold applications are known to reduce pain, spasm and swelling that follows injury. For best results, ice packs (crushed ice and towel) should be applied directly to the skin. Frozen gel packs should not be used directly against the skin, because they reach much lower temperatures than does ice packs. A good rule of thumb is to apply a cold pack to a recent injury for a 20-minute period and repeat every 1 to 1 1/2 hours throughout the waking day. Depending on the severity and site of the injury, cold may be applied intermittently for 1 to 72 hours.

#### **Compression**

Placing external pressure on an injury assists in decreasing hemorrhaging and hematoma (collecting of blood) formation. Many types of compression are available. An elastic wrap that has been soaked in water and frozen in a refrigerator can

provide both compression and cold when applied to a recent injury. Although cold is applied intermittently, compression should be maintained throughout the day. At night when circulation slows, it is best to remove the wrap completely and elevate the body part above the heart to avoid pooling of fluids.

### ***Elevation***

Along with cold and compression, elevation reduces bleeding and helps drain fluid that has leaked into the tissue from ruptured capillaries.

## **IMPACT INJURIES**

Diving is a collision sport, and water can feel as hard as cement when impacted from 10 meters. Water impact injuries may result in: open wounds (skin splits); internal bleeding; severe pain; eye injury; bloody nose; bruising; vomiting; muscle spasms; broken ear drum; tissue swelling at the site of impact; and/or rotator cuff tear. First aid treatment for some of these injuries has been discussed previously. The following will address injuries which have not been discussed as yet.

### **Eye Injuries**

While there are a variety of eye injuries the following includes general treatment which should take place for any of them.

#### ***First Aid Care***

Proper care of eye injuries is essential, and the coach must use extreme caution in handling them. If there appears to be retinal detachment, perforation of the globe, a foreign object embedded in the cornea, blood in the anterior chamber, decreased vision, loss of the visual field, poor pupillary adaptation, double vision, laceration, or impaired lid function, the diver should immediately be referred to a hospital or an ophthalmologist. Ideally, the athlete with a serious eye injury should be transported to the hospital lying down in an ambulance. Both eyes must be covered during transport. Covering both eyes during transport will limit eye movement. If one eye is still functional, it will move if uncovered and, in turn, the injured eye will move. At no time should pressure be applied to the eye. In case of surrounding soft-tissue injury, a cold compress may be applied for 30 to 60 minutes to control bleeding.

### **Nose Bleed**

(See pp. 141-142 of the [Sport Safety Training Handbook](#).) The critical factor relating to nose bleeds in diving is the amount of time the diver should stay out of the water. The intent of first aid care is to cause the blood to clot, thereby stopping the blood flow. Divers exhale during entries and this could dislodge the clot. Not only does the nose begin bleeding again, you also end up with a blood clot in the water. Allow ample time for the bleeding to stop before entering the water. Appropriate time varies according to the blood's ability to clot.

Because of this, a set amount of time is difficult to recommend. Apply a small amount of petroleum jelly to the inside of the nose.

### **Ruptured Eardrum**

Eardrum perforations or traumatic rupture of the tympanic membrane can be caused by a sudden blow across the ear or by rapid pressure changes from descending in the water. **Coaches should suspect eardrum injury if bleeding from the ear canal is noted.** Such injuries are characterized by sharp pain, slight hearing impairment, and slight bleeding. Ruptured eardrums normally heal spontaneously, but should be under a physician's care. Follow the physician's directions relating to time needed for healing before reentering the water since infection from water seepage into the inner chambers is a possibility.

It is also possible to rupture an eardrum by descending too deeply into the water. There is an air space between the inner ear and eardrum. During descent, water pressure compresses this air space and causes the eardrum to flex inward. This is what causes discomfort or pain at depth. If the pressure is not equalized, the eardrum will rupture. In competitive diving, generally the diver exhales during descent, which assists in equalizing the air pressure in the middle ear. If the diver has allergies, a cold or congestion, the eustachian tube (structure connecting the middle ear to the nasal passage) may swell. This makes it difficult for the air pressure to be equalized in the middle ear causing the eardrum to rupture. Diving should be discontinued if such an injury occurs.

### **Genital Injuries**

Injury to the female genitalia is very uncommon in diving. A much more common injury is to the external genitalia of the male athlete. The testes are vulnerable to injury in feet-first entries or severe impact with the water. These injuries usually occur as the result of a direct blow to the scrotum. The resulting forces can cause a testicular contusion or torsion. The pain may be associated with local spasm, bleeding, or bloody discharge. An athlete may also complain of a drawing sensation as the muscles attached to the testes go into spasm. Two methods of reducing testicular spasm are commonly used. One is to instruct or assist the athlete in bringing both knees up toward his chest (See Figure 10.2.1). This assists in relaxing the muscle spasms and reducing discomfort. Another maneuver often used by athletic trainers is illustrated in Figure 10.2.2. With the diver sitting on the deck, lift him about 2 to 3 inches and drop him to the floor. This results in a mild jolt to the genitalia and may assist in relaxing the testicular muscle spasm. Some caution should be employed in using this drop technique, especially if pain persists. The signs and symptoms associated with most genital injuries normally subside in a few minutes and require no further evaluation. However, if symptoms do persist or develop over time, or if there is visible bruising, swelling or bleeding, the athlete should be referred to medical assistance for further evaluation and treatment.



*Figure 10.2.1  
Genital injury -  
stretching*



*Figure 10.2.2  
Genital injury -  
lift and drop*

## OTHER DIVING-RELATED INJURIES

### DENTAL INJURIES

Occasionally a diver will chip or break a tooth or even dislodge a tooth. First Aid care may be found in the [American Red Cross Sport Safety Training Handbook](#), pp. 164-165.

About four percent of U.S. Diving injuries reported involve the teeth. Any blow to the upper or lower jaw can potentially injure the teeth. Injuries to the tooth below the gum line may repair themselves because of the abundant blood supply. However, fractures of the tooth below the gum line may not heal if there is an injury to the tooth pulp. Even though not obvious, a tooth could sustain a mild blow that disrupts its blood and nerve supply.

### Partially or Completely Dislocated Tooth

A tooth that has been knocked crooked should be manually realigned to a normal position as soon as possible. One that has been totally knocked out should be cleaned with water and replaced in the tooth socket, if possible. Rinse the tooth, do not scrub it. If repositioning the dislocated tooth is difficult, the diver should keep it under the tongue until the dentist can replace it. If this is inconvenient, a dislodged tooth can also be kept in a glass of water or milk. If a completely dislodged tooth is out of the mouth for more than 30 minutes, the chances of saving it are very slim; thus, the diver should be sent to the dentist immediately.

## SINUS SQUEEZE (BAROTRAUMA)

As discussed previously, descent into the water creates pressure on any air spaces in the body. Sinuses have air spaces and when they are open, the air automatically adjusts to the surrounding pressure. If the sinus is closed due to a cold, allergies, or other congestion, changes in air pressure may damage the sinus cavity. Increased pressure at depth will cause sharp pain in the sinus area. This pain may be located in the forehead, cheeks or upper teeth. If the diver has sharp pain during descent, discontinue water activities until the sinus opens. Sinuses can be opened by using a nasal decongestant in tablet or spray form. Coaches and physicians should be aware that many of these are on the International Olympic Committee (IOC) Medical Commission's banned substance list even the over-the-counter brands.

## BITES AND STINGS

Information relating to bites and stings is located in [American Red Cross Sport Safety Training Handbook](#), pp. 74-85.

One of the most important things to know about bites and stings is that some people have a life-threatening **anaphylactic reaction** to them. Each year in the United States 400 to 800 deaths are caused by severe allergic reactions. These deaths frequently occur within minutes of the onset of the reaction. People who die from anaphylaxis do so either from anaphylactic shock (25%) or from respiratory failure (75%).

The most dangerous complication of a severe allergic reaction is respiratory distress. Therefore, specific attention must be directed at airway and breathing assessment.

Swelling of the tissues of the oropharynx and larynx may lead to airway obstruction, which will be evident by the presence of stridor. Stridor is characterized by a high-pitched "crowing" sound often associated with hoarseness. Swelling in the mouth and tongue is not critical, but vocal cord swelling may be.

Swelling and spasm of the smaller airway passages may be manifested by a high-pitched whistling sound (wheezing) from the lungs. Abdominal cramps and vomiting may occur. Also, significant itching may be present.

### First Aid Care

It is important for the coach to have prior knowledge of any possible allergic reactions a diver may have. Divers with known allergies should have allergy medicine on hand at all times and the coach should be familiar with administration of the medication. For known bee-sting allergies, the athlete should have an EPI-PFN (injectible epinephrine) in his/her duffel bag. This should also be part of the first aid kit at all pools and part of the travel first aid kit when practice or competition takes place at an outdoor facility. The diver should have a supply of epinephrine on hand at all diving activities. If the diver has the signs and symptoms of shock, respiratory difficulty, or rapidly progressing symptoms, and does not have epinephrine, immediate transport to a medical facility is necessary. Call EMS – the coach should not try to transport the victim.

## SUDDEN ILLNESS

See pp. 157-162 in American Red Cross Sport Safety Training Handbook for information relating to fainting, diabetic emergency, and seizure on deck.

## HEAT AND COLD EMERGENCIES

Information relating to heat emergencies is located in American Red Cross Sport Safety Training Handbook, pp. 127-128.

Athletes who often keep working even after they develop the first signs or symptoms of heat-related illness are at risk. Heat cramps, heat exhaustion, and heat stroke are conditions caused by overexposure to heat and are often accompanied by dehydration. Heat cramps are the least severe condition but are often the first indicator of a problem. Heat exhaustion and heat stroke are more serious, and have already been addressed in this chapter.

### Heat Cramps

Heat cramps were discussed in Part 1, page 184. They can be avoided by drinking ample fluids prior to and during diving practice or competition. A diver is more susceptible to heat cramps if time is spent in a spa before, during and/or after practice.

### Sun Burn

Information relating to sun burn is located in the American Red Cross Sport Safety Training Handbook, pp. 162-163. The diving coach needs to remember that the diver is more susceptible to sun burn at the beginning of the outdoor season. Protect the diver as much as possible during this part of the season. Provide shade for the divers and instruct them to stay in the shade as much as possible. Use water proof sunscreens. Recognize that use of some medications (including many anti-inflammatories) may cause photosensitivity. This will result in a blotchy red rash following exposure to UV light, and it may be confused with sunburn.

### Hypothermia

Serious stages of hypothermia are extremely rare in diving. The most likely condition will be mild to moderate hypothermia. Regardless, this condition needs to be addressed by the coach because it could result in injury to the diver. Signs and care for hypothermia are located in the American Red Cross Sport Safety Training Handbook, pp. 108-109.

## SUMMARY

There are diving-related injuries which can be either life-threatening or non-life-threatening. There can be breathing emergencies, musculoskeletal injuries, and/or soft-tissue injuries to which the coach must attend. Proper first aid care for injuries is a responsibility of the coach and is the first step in the road to recovery. Coaches should review first aid and CPR skills on a regular basis in order to provide effective care in the case of an emergency. Make sure a first aid kit is available

for one's use at the diving facility. Periodically inspect the kit for proper materials and replace materials which have been used. Know the protocol for your Emergency Action Plan and practice it. Preparation and practice for emergency situations will assist in providing appropriate care for a diver when the need arises.

## REFERENCES

- American Red Cross (1997) Sport Safety Training Handbook, St. Louis, MO: Mosby/Lifeline.
- American Red Cross (1997) Sport Safety Training Workbook, St. Louis, MO: Mosby/Lifeline.
- American Red Cross (1996) First Aid: Responding to Emergencies, St. Louis, MO: Mosby/Lifeline.
- Arnheim D (1989) Modern Principles of Athletic Training, St. Louis, MO: Times/Mirror/Mosby College Publishing.
- Booher J, Thibodeau G (1985) Athletic Injury Assessment. St. Louis, MO: Times/Mirror/Mosby College Publishing.
- Clarke KS (1997) U.S. Diving injury surveillance database 1993-1996 Quadrennium Report. In U.S. Diving Coach Development Reference Manual (in progress).
- Gallaspy J, May J (1996) Signs and Symptoms of Athletic Injuries, St. Louis, MO: Mosby
- Rubin BD (1990) Orthopedic care. In Gabriel JL, George GS (eds.): U.S. Diving Safety Manual. Indianapolis, IN: U.S. Diving Publications, p. 27.

## Part 3. Health and Disease Transmission

There are other safety issues with which the diving coach must be concerned. The issues which will be addressed in this chapter include exposure to the sun, blood-borne pathogens and fecal contamination. The diving coach needs to be familiar with these issues in order to maintain a healthy and safe environment for all personnel involved in the diving program.

### PROCEDURES FOR DEALING WITH BLOOD-BORNE PATHOGENS

Blood-borne pathogens are disease causing microorganisms found in human blood and other bodily fluids. The two diseases that most concern aquatic personnel are Human Immuno Virus (HIV) and Hepatitis B Virus (HBV) because they are known to cause very serious illness and death. **Hepatitis B Virus can be transmitted through salt water, fresh water (lakes, rivers, and ponds) and improperly treated swimming pool water contaminated by human blood or bodily fluids during an accident.** Bodily fluids and excretions known to carry pathogens include blood, saliva, nasal discharges, vomitus, tears, and other excretions. Other dangerous excretions include the bloody froth that can be found in the mouth, urine and feces, all of which can be present during an active drowning.

### PERSONAL PROTECTION FOR AQUATIC PERSONNEL

Diving coaches must treat all bodily fluids as hazardous materials, and, in an emergency, consider all fluids as contaminated. Because of the risk of contamination, every aquatic facility should provide HIV/HBV Precautionary Kits, pocket masks, suction kits, and training in the use of these fundamental and inexpensive barrier protection items. If no one on staff has the minimum training necessary to teach staff members the use of this equipment, the coach should contact a local EMS service, which can also provide advice on the type of equipment best suited for one's operation.

Protocols for use, clean up and disposal of medical waste and used equipment must be clearly defined and their use mandated. These steps should be printed in one's facility operation manual. The following recommendations meet or exceed guidelines established by the Centers for Disease Control of the United States Public Health Services, are consistent with the Occupational Safety and Health Administration Act (OSHA) requirements, and should be adopted by each diving coach as the standard of care for accidents occurring at swimming pools and spas. Basic Protocols include:

- ***Wear at least one pair of latex gloves and learn how to take them off by using the following procedures:***

- *Grasp the top or wrist part of one glove, being careful to touch only the glove.*

- *Pull the glove down toward the fingers, turning it inside out. Continue to hold onto the glove.*

- *Insert one or two clean fingers into the top of the other glove. Be careful not to touch the outside surface.*

- *Pull the glove off, turning it inside out while pulling it over the first glove. Now the first glove taken off is inside the second glove, and both are turned inside out.*

- *Discard the gloves into a red plastic medical waste bag with the biohazard symbol on it.*

- *Dispose of the medical waste bag in accordance with protocols established by the Department of Health, local hospital, EMS Service or local municipal code.*

- ***Use some type of eye shield (goggles, sun glasses).***

- ***Begin assessment and resuscitation on deck with a resuscitation mask.***

### Protocol for Water Rescue by the Diving Coach

- ***Attempt to determine during the approach if blood is visible in the water.***

- ***If the victim is bleeding and active, avoid swimming in water contaminated by blood if possible. Extend the rescue tube to the victim and keep one's distance.***

- ***Avoid contact with bleeding victims as much as possible during the approach and while towing.***

- ***During both active and passive rescues, keep the routes of entry into the body (eyes, ears, nose, and mouth) above water at all times. Avoid ingesting water if there is obvious blood.***

- ***When assisting a conscious victim or removing a passive victim from the pool, it will not be possible to avoid direct contact. When two or more personnel are available for extrication, structure your accident management procedure so that the second rescuer is also equipped with barrier protection.***

- ***When first aid and/or CPR has been completed and EMS personnel have taken the victim to the hospital, rescuers should wash their hair and entire body with soap and water. Rinse the mouth with an antiseptic mouth wash, even if resuscitation was performed with a pocket mask.***

## Protocols for Facility and Equipment Sanitation

- For swimming pools and spas, appropriate free chlorine and bromine levels are the best defense against contamination from exposure to blood-borne pathogens. **The best range for a pool is 1.0-3.0 parts per million (ppm) free residual chlorine or 2.0-6.0 ppm free residual bromine.** For Spas a free chlorine residual of 3.0-5.0 ppm or 6.0-10.0 ppm of residual bromine is optimal.
- If blood contaminates the pool deck, coping, or walkways made of cement, granite, rock, or other porous surface material, mix 4 oz. of calcium hypochlorite (granular chlorine) or 16 oz. (one pint) of sodium hypochlorite (liquid chlorine) with 1 gallon of water. Be sure that either type of chlorine is fresh. Apply the solution on all contaminated surfaces with a garden sprayer and let stand for 5 minutes. Rinse the surface with water from a hose toward a swimming pool deck drain. Be sure that other aquatic staff members and divers have been cleared from the area before spray and rinse application. Sanitize the surface a second time, let sit and rinse thoroughly again. Allow the surface to dry completely before permitting anyone to walk on it or use it in any way.
- If blood contaminates hard surfaces such as the diving boards, platforms, rubber-type platform surface material, small deck area, bleachers or soft surfaces such as gymnastic mats, diving coaches and meet directors should see procedures for Disinfection of Surfaces and Equipment for Hard and Soft surfaces in this Appendix (see pg. 200).
- For grass, dirt, and sand surfaces contaminated by blood, mix a solution of chlorine and water using 4 oz. of fresh calcium hypochlorite or 16 oz. of sodium hypochlorite with 1 gallon of water. Apply the chlorine solution until the area where the blood spill occurred is thoroughly saturated with the chlorine solution. Rope off the area and prohibit sun bathing or other uses of the area until it is completely dry. If the contaminated area consists of dirt or sand, turn it over with a shovel and rake it. Saturate the sand or dirt again and continue to prohibit use until it dries and is raked a second time. Since grass will be killed by the chlorine solution, waterfront and outdoor pool operators may want to remove small quantities of sod and dispose of it in medical waste bags to be incinerated. Be sure to decontaminate any shovels, rakes, brooms or other tools used in the cleanup with the same strength chlorine solution and rinse thoroughly.
- Any personal equipment used in rescue, first aid, CPR, or oral suction that is reusable must be properly sanitized before it is used again. This includes, but is not limited to, rescue tubes, plastic back boards, straps, head immobilizers, and hard cervical collars. These items should be cleaned with a quaternary ammonia disinfectant. Be sure to follow the instructions on the label. Disposable equipment such as

pocket masks and first aid materials must be disposed of in medical waste bags.

## Exposure Plan

It is the responsibility of the Aquatics Director at your facility to develop and implement a comprehensive Blood-Borne Pathogen Exposure Plan. If one is not available at the training facility, the diving coach should develop a plan. The plan must include elements of prevention and protocols for handling an actual exposure. To prevent an exposure or an illness from an exposure:

- Develop and write communicable disease protocols for rescue, first aid, and resuscitation.
- Communicate these protocols in writing in your policies and procedures manual. Review them with other individuals involved with the diving program (assistant coaches, divers).
- Practice using personal protective equipment and clothing.
- Recommend Hepatitis B vaccinations for anyone exposed to blood-borne pathogens. The vaccine is recommended for athletes in contact/collision sports (diving is a collision sport).
- Establish protocols for post-exposure follow-up. For example, individuals who have been in contact with blood or bodily fluids should not eat, drink, or smoke, apply cosmetics, or sun block, or handle contact lenses prior to cleaning up after an exposure. Items of personal clothing such as bathing suits, T-shirts, hats, sweat shirts, pants and equipment should be treated as medical waste or laundered separately from other clothing. Detergent and hot water or dry cleaning are acceptable cleaning methods.
- Keep written records of one's protocols, exposure and incident reports.
- Provide the equipment necessary to ensure that one can handle contaminated material safely. Have such equipment available at all practices and competitions.

## Protocols for Handling and Exposure

- Make a thorough assessment of an accident involving blood and maintain confidentiality regarding the victim and personnel involved.
- Be sure to report incidents involving blood to your supervisor or aquatics director.

Proper precautions regarding injuries will help maintain an atmosphere of safety and will keep individuals involved in the rescue process from harm. The diving coach must develop policies for dealing with blood-borne pathogens and review those policies with others involved with the diving program.

## **FECAL CONTAMINATION IN THE SWIMMING POOL**

Fecal contamination in swimming pools is an old problem but there are new concerns. Aquatic administrators, swimming teachers, coaches and lifeguards have had to deal with this problem in the past, and unfortunately proper protocol for handling fecal matter is not common knowledge at aquatic facilities.

In the past, it has been very difficult to locate information on fecal contamination. Recently, policies for the YMCA of the USA (Johnson, 1997) were established which answer many questions relating to safe and effective treatment of contaminated water. It is advisable to include these procedures in your emergency action plan and your policies and procedures manual. Fecal contamination does not necessarily have to be introduced to the pool by members of the diving team. Other swimmers may present the problem but the diving coach may be the one who ends up confronting it. The following information will clarify the hazards and how to deal with them.

Three organisms identified in recent swimming pool outbreaks include Nematodes, Giardia Lamblia, and Cryptosporidium parvum. All three are resistant to chlorine in varying degrees, and all three can be easily transferred from animals to humans, or from human to human.

**Nematodes** can cause asthmatic attacks, pneumonia, blood loss, iron deficiency, nausea, fever, muscle pain, generalized edema, diarrhea, intestinal blockage and abdominal pain.

**Giardia** locates itself in the small intestines and will generally manifest diarrhea, stomach cramps, fatigue, nausea, bloating (gas) and weight loss. Some infected people will show no symptoms, some will recover without medical treatment, while others will become constipated. Giardiasis rarely requires hospitalization.

**Cryptosporidium parvum** is an intestinal parasite which has an extremely high resistance to chlorine. A single fecal accident, even in a large pool, can cause illness to a great number of people. Symptoms include vomiting, abdominal cramps, bloated stomach (gas), copious yellow diarrhea, loss of fluids and electrolytes.

### **Strategies for Preventing the Introduction of Intestinal Parasites into the Pool**

The best defense against an outbreak of intestinal disease in a pool is to establish a series of preventive measures. These measures include the following:

- *Maintain filtration and disinfection systems in good working order.*
- *Use some form of chlorine as a disinfectant.*
- *Maintain an effective free chlorine residual:*  
**Pool: 1.0-2.0 parts per million (ppm), Spa: 3.0-5.0 ppm, Wading pool 2.0-3.0 ppm. Keep the pH between 7.2-7.6.**

• *Use a chemical feeder to dispense chlorine into the pool 24 hours per day.*

• *Operate the circulation system 24 hours a day.*

• *Test, adjust, and record chlorine and pH levels every 2 hours for pools and wading pools, or once an hour in spas.*

• *Drain and scrub the walls and pool bottom once a year.*

• *Superchlorinate the pool once a month to a free residual of 5.0 ppm*

• *Establish hygiene rules for the pool and spa.*

• *Provide diaper changing stations in both the men's and women's dressing room for parents with infants.*

• *Install "child acceptable" toilet facilities and strongly recommend to parents that they encourage their use before bringing toddlers and preschool age children into the pool.*

• *Make sure that infants and toddlers using the pool have swimsuits or diapers that are properly sealed at the legs and waist.*

• *Be sure that spray pools for toddlers and preschoolers do not have any standing water or untreated recirculating water.*

### **Strategies for Dealing with a Visible Episode of Fecal Contamination**

When dealing with a visible incident of fecal contamination, the type of bacteria, virus or parasite that might be in the water will not be known. Thus, one must assume the worst case scenario and treat the incident as though the most chlorine resistant organism is present in the water. In order to eliminate these organisms, two factors must be considered: 1) the concentration of the disinfectant in parts per million (ppm); and, 2) the time in minutes necessary to eliminate 99.9% of the organism. The formula CT (Concentration X Time) is used to express this relationship. The disinfectant used in the process is chlorine. For example, the formula for Giardia Lamblia is  $CT = 15$ . So to eliminate 99.9% of the Giardia oocysts from a pool known to have this parasite, the manager must raise the free chlorine residual to 1.0 ppm (C) for 15 minutes ( $1.0 \text{ ppm} \times 15 \text{ minutes} = 15$ ). Since this application will eliminate 99.9% of the organisms it would be wise to maintain the 1.0 ppm for 20 minutes which would yield a  $CT = 20$ . If your pool uses Bromine then the C (concentration) must be doubled to achieve the equivalency of Chlorine.

Since organisms that are present in the feces will not have been identified by a laboratory, the pool should be immediately treated for the organism with the highest CT. The organism is Cryptosporidium parvum,  $CT = 9600$ . To completely eliminate this parasite increase to  $CT = 10,000$ .

The following protocol should be followed immediately after recognition of fecal contamination:

- All pool users should be required to leave the pool, and the pool should be closed.
- Remove as much fecal material as possible from the pool. If the pool bottom is vacuumed, waste water should be channeled directly to a sewer or approved waste disposal system, not through the filtration system. Vacuum equipment must be cleaned and disinfected with sodium hypochlorite (liquid chlorine) before resuming use.
- The free chlorine residual should be raised to 20.0 ppm, and a pH level of 7.2 should be maintained for at least nine hours. This is the equivalent of an approximate CT value of 10,000. A higher or lower chlorine residual may be used, provided a CT value of 10,000 is achieved.
- The filtration system should be operated for a minimum of three to six complete turnovers. A turnover is pumping all of the water in the pool through the filter. Three turnovers can be achieved within a 24 hour period in all public pools.
- After three to six turnovers, thoroughly clean or backwash the filter.
- If the pool is a low volume pool, such as a spa or wading pool, drain the pool at this point.
- Disinfect the filter tank and filter media by applying a 20:1 solution of liquid chlorine directly to the filter.
- Restart the filtration system.
- Neutralize any excessively high chlorine residual with sodium thiosulfate penta hydrate. Balance the water (proper pH, chlorine, calcium hardness, total alkalinity and temperature) and reopen the pool.

This process will ensure safe use of the facility after an incident of fecal contamination. It may seem like a lot of extra work, but it's the only way to keep your facility disease-free.

## **EFFECTS OF OVEREXPOSURE TO THE SUN**

Americans love the sun and spend increasing amounts of time outside – working, playing, exercising – often in clothing that leaves a lot of skin exposed. Most people are now aware that too much sun has been linked to skin cancer, but few know the degree of risk posed by overexposure, and fewer are aware that the risks go beyond skin cancer. Recent medical research has shown that overexposure to the sun's ultraviolet (UV) radiation can contribute to serious health problems. In order to protect divers and oneself from the effects of ultraviolet radiation, it is critical that the coach use precautions to avoid risks from exposure to the sun now and in the future.

The following information provides a quick overview of the major problems linked to UV exposure: skin cancer (melanoma and non-melanoma); other skin problems; cataracts; and immune system suppression. Understanding these risks and taking a few sensible precautions will help you and your divers enjoy the sun while lowering your chances of sun-related problems later in life.

## **MELANOMA**

Melanoma, the most serious form of skin cancer, is also one of the fastest growing cancers in the U.S. Many dermatologists believe that there may be a link between childhood sunburns and malignant melanoma later in life. Cases of melanoma in this country have almost doubled in the past two decades, with at least 32,000 cases of melanoma and 6,900 deaths estimated for 1994 alone. The rise in melanoma in America is expected to continue.

### ***Cure Rate***

Melanoma can spread to other parts of the body quickly, but when detected in its earliest stages it is almost always curable. If not caught early, melanoma is often fatal.

### ***What to Watch For***

Melanoma begins as an uncontrolled growth of pigment-producing cells in the skin. This growth leads to the formation of dark-pigmented malignant moles or tumors, called melanomas. Melanomas may suddenly appear without warning, but may also develop from or near a mole. For this reason, it is important to know the location and appearance of moles on the body so any change will be noticed. Melanomas are found most frequently on the upper backs of men and women, and on the legs of women, but they can occur anywhere on the body.

Divers and coaches should be aware of any unusual skin condition, especially a change in the size or color of a mole or other darkly or irregularly pigmented growth or spot; scaliness, oozing, bleeding or change in the appearance of a bump or nodule; spread of pigment from the border into surrounding skin; and changes in sensation, including itchiness, tenderness, or pain.

## **NON-MELANOMA SKIN CANCERS**

Unlike melanoma, non-melanoma skin cancers are rarely fatal. Nevertheless, they should not be taken lightly. Untreated, they can spread, causing more serious health problems. An estimated 900,000 Americans developed non-melanoma skin cancers in 1994, while 1,200 died from the disease.

There are two primary types of non-melanoma skin cancers:

### **Basal Cell Carcinomas**

These are tumors of the skin which usually appear as small, fleshy bumps or nodules on the head and neck, but can occur on other skin areas as well. It is the most common skin cancer found among fair-skinned people. Basal cell carcinoma

does not grow quickly and rarely spreads to other parts of the body. However, it can penetrate below the skin to the bone and cause considerable local damage.

### **Squamous Cell Carcinomas**

These are tumors which may appear as nodules or as red, scaly patches. The second most common skin cancer found in fair-skinned people, squamous cell carcinoma is rarely found in darker-skinned people. This cancer can develop into large masses, and unlike basal cell carcinoma, it can spread to other parts of the body.

#### ***Cure Rate***

These two non-melanoma skin cancers have high cure rates – as high as 95 percent if detected and treated early. The key is to watch for signs and to detect the cancer in its early stages.

#### ***What to Watch For***

Basal cells carcinoma tumors usually appear as slowly growing, raised, translucent, pearly nodules which, if untreated, may crust, discharge pus, and sometimes bleed. Squamous cell carcinomas usually are raised, red or pink scaly nodules or wart-like growths that form pus in the center. They typically develop on the edge of the ears, the face, lips, mouth, hands and other exposed areas of the body.

### **Actinic Keratoses**

These sun-induced skin growths occur on body areas exposed to the sun. The face, hands, forearms and the “V” neck are especially susceptible to this type of blemish. They are premalignant, but left untreated, actinic keratoses can become malignant. Look for raised, reddish, rough-textured growths. See a dermatologist promptly if you notice these growths.

### **Photoaging**

Chronic exposure to the sun causes changes in the skin called actinic, or solar, degeneration. The skin over time becomes thick, wrinkled, and leathery. This condition has often been referred to as “premature aging” of the skin. Since it occurs gradually, often manifesting itself many years after the majority of a person’s exposure to the sun, photoaging is often regarded as an unavoidable condition, a normal part of growing older. With proper protection from UV radiation, however, photoaging can be substantially avoided.

### **Cataracts and Other Eye Damage**

Cataracts are a form of eye damage, a loss of transparency in the lens which clouds vision. Left untreated, cataracts can rob people of vision. Research has shown that UV radiation increases the likelihood of certain cataracts. Although curable with modern eye surgery, cataracts diminish the eyesight of millions of Americans, and necessitate millions of dollars of eye surgery each year. Other kinds of eye damage include: pterygium (tissue growth on the white of the eye that can block vision), skin cancer around the eyes, and degeneration of the

macula (the part of the retina near the center, where visual perception is most acute). All of these problems could be lessened with proper eye protection from UV radiation.

### **Immune Suppression**

Scientists have found that sunburn can alter the distribution and function of disease-fighting white blood cells in humans for up to 24 hours after exposure to the sun. Repeated exposure to UV radiation may cause more long-lasting damage to the body’s immune system. Mild sunburns can directly suppress the immune functions of human skin where the sunburn has occurred, even in people with dark skin.

### **About the UV Index**

The UV Index, developed by the National Weather Service and the Environmental Protection Agency, provides a forecast of the expected risk of overexposure to the sun and indicates the degree of caution you should take when working, playing, or exercising outdoors. The UV Index predicts exposure levels on a 0 to 10+ scale, where 0 indicates a minimal risk of overexposure and 10+ means a very high risk of overexposure. Calculated on a next-day basis for dozens of cities across the U.S. by the National Weather Service, the UV Index takes into account clouds and other local conditions that affect the amount of UV radiation reaching the ground in different parts of the country.

#### ***UV Index Values Exposure Category***

0 - 2	Minimal
3 - 4	Low
5 - 6	Moderate
7 - 9	High
10+	Very High

#### ***Special Considerations for Children***

Although many of the sun’s worst effects do not appear until later in life, recent medical research has shown that it is very important to protect children and teenagers from overexposure to UV radiation. The majority of most people’s sun exposure occurs before age 20, and studies increasingly suggest a link between early exposure and skin cancer as an adult. Many drugs cause photosensitivity, especially anti-inflammatories and some antibiotics. Be aware of this possibility and advise divers who are on these medications to be especially careful regarding sun protection.

### **Action Steps for Sun Protection**

Be Sun Wise: Protecting yourself from overexposure to UV radiation is simple:

- Wear sunglasses that block 99-100% of UV radiation. Sunglasses that provide 99-100% UVA protection will greatly reduce sun exposure that can lead to cataracts and other eye damage. Check the label when buying sunglasses.

- Wear a Hat. A hat with a wide brim offers good sun protection to your eyes, ears, face and the back of your neck – areas particularly prone to overexposure to the sun.*
- Protect other areas of your body with clothing during prolonged periods in the sun. Tightly-woven, loose-fitting clothes are best, but more clothing is always better than less.*
- Always use a sunscreen when outside on a sunny day. A sunscreen with a Sun Protection Factor (SPF) of at least 15 blocks most harmful UV radiation. Apply sunscreen liberally and reapply every two hours when working, playing, or exercising outdoors. Even waterproof sunscreen may come off when you towel off sweat or water.*
- Avoid the midday sun as much as possible. The sun's UV rays are strongest between 10 a.m. and 4 p.m. If possible, limit exposure to the sun during these hours.*
- Avoid sunlamps and tanning parlors. Sunbeds damage the skin and unprotected eyes, and are best avoided entirely.*
- Watch for the UV Index.*

For more information, call EPA's Stratospheric Ozone Hotline at (800) 296-1996.

## SUMMARY

There are certain health issues with which the diving coach must be concerned. Injuries do occur in competitive diving, and the coach must know how to deal with blood-borne pathogens. Proper handling of the victim and appropriate clean-up methods will minimize the risk of transmission of HIV or Hepatitis B Virus.

Occasionally, the coach must deal with the serious risks posed by fecal contamination. The pool should be closed until proper chlorination can be administered in order to kill intestinal parasites. Proper treatment of the water after an episode of contamination will provide for the safety of the divers in your program, and anyone else who may use the facility.

Exposure to the sun is another concern of the coach and diver. You can help protect your divers and yourself from sunburn and other potential skin and eye maladies by minimizing exposure to the UV rays of the sun. Educate your athletes to the risks of overexposure to the sun.

Knowledge of these issues of health will assist in maintaining a healthy environment for the divers and coach. All of the maladies addressed in this chapter are preventable. Protect your divers and others who may utilize the facility through conscientious efforts to provide a healthy environment.

## REFERENCES

- Johnson, R. L. (1997). "Fecal Contamination: An Old Swimming Pool Problem With New Concerns". Manuscript received at Indiana University of Pennsylvania Aquatic School, June, 1997.
- Johnson, R. L. (1994). YMCA Pool Operations Manual. Human Kinetics Publishers, Champaign, IL.
- United States Environmental Protection Agency (1995). "Health Effects of Overexposure to the Sun". American Red Cross. April.
- United States Environmental Protection Agency (1995). "Action Steps for Sun Protection", American Red Cross. April.

## **APPENDIX: HIV VIRUS & SPORT: PRECAUTIONS AGAINST RISK OF CONTAMINATION**

Publicity about human immunodeficiency virus (HIV) infection of Greg Louganis and other high profile athletes has focused attention on the potential for transmission of blood-borne pathogens during athletic and aquatic sports competitions. Existing information suggest that the potential risk for such transmission is extremely low and the principal risks athletes have for acquiring HIV and hepatitis B virus are related to non sport settings. Athletes may be at more of a risk for HIV and HBV infection through sexual contact. Athletes who inject or allow themselves to be injected with steroids or other drugs are at risk if syringes, needles, or other injection-related paraphernalia are shared. A study of on-the-field bleeding injuries during American football concludes that the risk for HIV transmission to each player is less than 1 per 85 million game contacts). Hepatitis B virus is more likely than HIV to be transmitted because it is present in higher concentrations in the blood. Although no cases of HIV transmission during sports has been documented and no cases of hepatitis B attributed to sports activities have been reported to the Centers for Disease Control and Prevention in the United States, non-sports related incidences of transmission of HIV during bloody fistfights and the isolated case of documented HBV transmission in Japanese sport attributed to a sumo wrestler who had many scars and bled often from injuries, supports the logic of preventing blood contact as prudent.

The following conditions must exist for a blood-borne pathogen to be transmitted during a sporting activity: 1) the presence of an infected athlete; 2) the occurrence of a bleeding wound or exudative skin lesion in an infected athlete; 3) the presence in a susceptible athlete of a skin lesion or exposed mucous membrane that could serve as a portal for systemic entry of a blood-borne pathogen; and 4) sustained contact between the portal of entry of the susceptible athlete and the infective material. HIV is not transmitted through saliva, sweat, tears, urine, respiratory droplets, handshaking, swimming pool water, communal bath water, toilets, food or drinking water.

### **UNIVERSAL PRECAUTIONS FOR HEALTH-CARE WORKERS**

(including Lifeguards and First Aid Responders)

1. All health-care workers should routinely use appropriate barrier precautions to prevent skin and mucous-membrane exposure when contact with blood or other body fluids of any patient is anticipated. Gloves should be worn for touching blood and body fluids, mucous membranes or non-intact skin of all patients, for handling items or surfaces soiled with blood or body fluids and for performing venipuncture and other vascular procedures. Gloves should be changed after contact with each patient. Masks and protective eyewear or face shields should be worn during procedures that are likely to generate droplets of blood or other body fluids to prevent exposure of mucous membranes of the mouth, nose and eyes. Gowns or aprons should be worn during procedures that are likely to generate splashes of blood or other body fluids.
2. Hands and other skin surfaces should be washed immediately and thoroughly if contaminated with blood or other body fluids. Hands should be washed immediately after gloves are removed.
3. All health-care workers should take precautions to prevent injuries caused by needles, scalpels and other sharp instruments or devices during procedures; when cleaning used instruments; during disposal of used needles; and when handling sharp instruments after procedures. To prevent needlestick injuries, needles should not be recapped, purposely bent or broken by hand. After they are used, disposable syringes and needles, scalpel blades and other sharp items should be placed in puncture-resistant containers for disposal; the puncture-resistant containers should be placed in a puncture-resistant container for transport to the processing area.
4. Although saliva has not been implicated in HIV transmission, to minimize the risk related to emergency mouth-to-mouth resuscitation, mouth-pieces, resuscitation bags or other ventilation devices should be available for use in areas in which the need for resuscitation is predictable.
5. Health-care workers who have exudative lesions or weeping dermatitis should refrain from all direct patient care and from handling patient-care equipment until the condition is resolved.
6. Pregnant health-care workers are not known to be at greater risk of contracting HIV infection than health-care workers who are not pregnant; however, if a health-care worker develops HIV infection during pregnancy, the infant is at risk of infection resulting from perinatal transmission. Because of this risk, pregnant health-care workers should be especially familiar with and strictly adhere to precautions to minimize the risk of HIV transmission.

## SPECIFIC PRECAUTIONS FOR SPORT

Precautions can be undertaken during/prior to sports participation to reduce the risk of HIV and HBV transmission and should include:

1. Educational information including information about activities that place individuals at high risk because of lifestyle, geographic location, or a specific sport should be made available to participants and those deemed at risk (i.e. manager, coaches).

1.1 Athletes should be educated about abstinence, monogamy, the use of condoms, and other approaches to the prevention of sexually transmitted disease.

1.2 Athletes should be educated about the risks associated with nonmedical uses of injectable steroids and other drugs, and about the importance of not sharing needles, syringes, or other drug-related paraphernalia.

1.3 When resources permit, all adolescents and young adults should receive hepatitis B vaccine. In other circumstances, all athletes at increased risk for infection (for example, those who are injecting drug users, have other sexually transmitted diseases, or have a history of sexual activity with more than one partner in the previous 6 months) should receive hepatitis B vaccine.

1.4 Voluntary testing for HIV and HBV is made available to all athletes in the greatest and moderate risk sports. Other athletes perceived to be at risk should also have testing available to them.

1.5 Review athletes medical history to make sure that all routine vaccinations including tetanus and MMR (Measles, Mumps, Rubella) are up to date.

2. The following measures may be considered to ensure that the risk for transmission of blood-borne pathogens during sports remains extremely low:

2.1 For athletes or coaches participating in training or competition that involves person-to-person contact, skin wounds (such as scratches, abrasions, and lacerations) and potentially infectious skin lesions (such as vesicular or weeping skin lesions) should be securely covered with bandages to prevent leakage of blood or serous fluid during the sports activity. This measure provides protection from contamination from other sources.

2.2 Whenever a sports participant sustains a laceration or wound with substantial bleeding (more than superficial scratches or small lacerations), the injury should be treated promptly. Matches should be interrupted to allow the blood flow to be stopped, the area cleaned and the athletes cleaned. Blood on the skin of the injured athlete and on that of other participants should be washed off thoroughly with soap and

water or with a premoistened towelette. The injured athlete should be permitted to return to the sports activity only after the wound has been securely covered or wrapped.

2.3 Interruption of a sports activity for a change of equipment or uniform in situations in which an athlete is not actively bleeding is unwarranted. If an athlete's equipment (such as tape or padding) appears wet with blood or if blood has penetrated both sides of a uniform fabric, the equipment or uniform should be changed and blood on the skin should be washed off at the earliest convenient time (e.g. when play is stopped for other reasons). Small amounts of dried blood on uniforms or equipment do not constitute a risk for transmission of blood-borne pathogens.

2.4 Coaches or athletic trainers should use disposable examination gloves when treating athletes who are bleeding profusely. In addition, on the basis of Occupational Health and Safety Administration (OHSA) regulations, trainers whose routine responsibilities frequently expose them to blood should be offered preexposure prophylaxis hepatitis B vaccine. For trainers whose exposure to blood is infrequent, timely prophylaxis after exposure may be preferable to routine vaccination before exposure, unless vaccination is otherwise indicated.

3. There is no medical or public health basis for routine screening of athletes for HIV or HBV infection. Moreover, athletes need not be excluded from participation in a sports activity solely because they are infected with HIV or HBV. Information about a diagnosis of HIV or HBV infection should be maintained in a confidential manner.

4. Prudent hygienic and infection-control strategies to prevent transmission of all infectious diseases should be used in making decisions about the limitation of an athlete's participation in sports activities. For example, disciplinary rules forbidding unsportsmanlike activities (such as biting, scratching, or fighting) that may lead to blood contact during sports activities should be strictly enforced.

5. Coaches, trainers, athletes, and officials should be educated about basic principles of infection control, first aid, and hygiene.

5.1 To minimize contact, emergency mouth-to-mouth resuscitation bags or other ventilation devices should be available for use in emergencies.

5.2 Spittoons where bloody sputum or saliva may be spit should contain a solution known to inactivate the virus.

## DISINFECTION OF SURFACES AND EQUIPMENT

Media coverage about Greg Louganis' HIV infection at the time his head struck the springboard in the 1988 Olympic Games has focused attention on the extremely low potential for transmission of blood-borne pathogens during aquatic sports competition since HIV is not transmitted in pool water. To ensure that the risk for transmission of blood-borne pathogens remains extremely low, the following procedures are recommended to disinfect surfaces and equipment related to training and competition in the sport of diving:

Soiled towels, sammies and uniforms should be handled as little as possible to prevent microbial contamination of the air and of persons handling the linen and uniforms. All soiled materials should be bagged where it was used, double bagged if there is a chance of leakage, and transported to the laundry. Standard laundry cycles should be used according to the washer and detergent manufacturer's recommendations. If hot water is used, the soiled articles should be washed with detergent in water at least 160 degrees Fahrenheit (71 degrees Celsius) for 25 minutes. If low temperature (< 160 degrees Fahrenheit) laundry cycles are used, solutions known to inactivate the virus should be used. Laundry personnel should use appropriate physical barriers, such as reusable utility gloves, to prevent contact with soiled laundry. Although liquid chemical disinfectants with activity against specific blood-borne pathogens and other micro-organisms are widely available, such disinfectants are not intended for direct contact with the skin, and direct physical contact with such agents may result in skin irritation or other toxic reactions. These disinfectants are not intended for and may not be effective for disinfecting athletic uniforms or equipment while they are being worn by athletes.

Surfaces contaminated with blood or bodily fluid should be cleaned with a solution known to inactivate the virus after each injury or more often as needed. The mechanics of scrubbing are much more important in eliminating organisms than the cleansing agent selected. The end result of scrubbing and rinsing should be the thorough removal of all contaminated materials.

**Hard surfaces.** To clean the diving boards, platforms, rubber type platform surface material, deck, bleachers etc. contaminated with blood, diving coaches and meet directors should keep the following equipment available on site:

1. one 2 gallon bucket
2. impermeable (latex) gloves
3. household bleach (5.25 percent sodium hypochlorite)
4. one measuring cup
5. one plastic or fiber-bristle brush
6. paper towels
7. one (plastic) moisture resistant bag

### Procedure.

1. Use the measuring cup and bucket to mix household bleach (ie. solution of 5.25 percent sodium hypochlorite) and tap water in the bucket using no weaker a solution than 1 part bleach to 100 parts water, and no stronger than 1 part bleach to 10 parts of water (i.e. 1/2 cup bleach to 2 gallons (32 cups, 8 quarts) of tap water. This must be prepared fresh, and not allowed to stand more than 24 hours.

2. Wear impermeable gloves.

3. Contain the blood spill in the smallest area possible by absorbing the spill with paper towels.

**4. Decontaminate the hard surface with the mixed 5.25 percent hypochlorite and tap water or a comparable solution.**

5. Reclean hard surfaces using fresh disposable toweling. **Scrub the diving board using a plastic or fiber bristle brush.** Afterwards rinse the remainder into the pool water with the diluted bleach solution (HIV is not transmitted through swimming pool water). The end result of scrubbing and rinsing should be the thorough removal of all contaminated materials.

6. Place all soiled waste in the plastic moisture resistant bag.

7. Wash hands.

8. Trash and any waste contaminated with blood or bloody bodily fluids should

be regarded as potentially infectious and treated as biohazardous material.

**Soft Surfaces.** It is not recommended to use sodium hypochlorite solutions on soft surfaces such as carpets or rugs. Instead use a sanitary absorbent cleanser. Agents labeled "hospital disinfectants" are also acceptable cleaning agents and will eliminate HIV & HBV. Common agents that eradicate HIV and HBV include, but are not limited to: Lysol, hydrogen peroxide, betadine, glutaraldehyde, isopropyl alcohol, and Np-40 detergent. Chemical germicides registered with the Environmental Protection Agency (EPA) as sterilants are recommended for high-level disinfection.

For gymnastics mats, the cleaning agent must be a tuberculocidal, which indicates the cleanser will not only kill tuberculosis spores, but also the HIV and Hepatitis B virus. The cleaner should not destroy the vinyl in the mats, which eliminates the use of bleach cleaners. American Athletics Inc. (AAI) recommends the following cleaner to disinfect AAI apparatus and mats should blood be evident on them: Precise Hospital Foam Cleaner Disinfectant (spray), Item #40513, Caltech Industries, 2420 Schuette Drive, Midland, MI 48642  
Call 1-800-234-7700 for the name of your local distributor.

To clean soft athletic surfaces such as gymnastic mats, pit mats, and trampoline beds, diving coaches should keep the following equipment available on site:

1. impermeable (latex) gloves
2. appropriate absorbent cleaning agent that eradicates HIV/HBV
3. paper towels
4. moisture (plastic) resistant bag

### Procedure.

1. Wear impermeable gloves

2. Contain the blood spill in the smallest area possible by absorbing the spill with paper towels.

3. Decontaminate the soft surface with the appropriate absorbent cleaning agent according to directions.

4. Place all soiled waste in the moisture resistant bag.

5. Wash hands.

6. Trash and any waste contaminated with blood or bloody body fluids should be regarded as potentially infectious and treated as biohazardous material.

## REFERENCES

Based on excerpts from:

Global Programme on AIDS (1989) Consensus statement from consultation on AIDS and Sports. World Health Organization in collaboration with International Federation of Sports Medicine. Geneva, January 16.

Garl T, Hrisomalos T, Rink L (1992) Internal Medicine Associates of Bloomington, Inc. Reprinted by permission from: Olympic Coach, 2 (1): 1-2.

Mast EE, Goodman RA, Bond WW, Favero MS, Drotman DP (1995) Transmission of blood-borne pathogens during sports: risk and prevention. Annals of Internal Medicine, Atlanta, GA: Centers for Disease Control and Prevention, 122 (4): 283-285.



# Index

## A

Above ground sparging system 70  
  Design 70  
  Design specifications 71  
  Effectiveness 70  
  Insurance 70  
  Limitations 70  
  Maintenance 70  
  Operating procedures 70  
    Equipment operation 70  
    Start up safety check 70  
    Safety precautions 70  
  Variations 71  
    Compressor 71  
    Storage tank 71  
    Delivery system 71  
    Sparger head 71  
    Length 71  
    Configuration platform heights 71  
    Pool depth-water envelope 71  
    Safety Inspection & Maintenance 70  
Abrasions 125, 185  
Accident report 24, 41  
Actinic keratoses 196  
Alcohol 97, 114  
Assessments 130  
  Skill 32, 33, 34, 35, 130  
  Injury severity 145  
  Strength/power and flexibility 130  
Assumption of risk 6  
Areas of concern 11, 78  
  Alcohol 97  
  Collision in glide paths 97  
  Fear management 97  
  Gymnastic mats 78  
  NO-diving in shallow water 97  
  Overhead belt spotting 109  
  Spotting belts 90  
  Restricting unauthorized access 96  
  Spineboard 97  
  Springboard ladders 97  
  Teaching head-first dives  
    in nonconforming pools 97  
Armstand 115  
  Landing variations 112, 113  
Attendance 16  
Authorization to consent to medical  
  treatment of a minor 23  
Avulsion 185

## B

Backboarding 166  
  Deep water 169, 170  
  Placing victim 166  
  Procedures 169  
  Removing victim 172  
  Selecting a backboard 166  
  Shallow water 174  
Back up plans 51  
Basal cell carcinomas 195  
Basic drops 112, 113  
Basic resistance training 131  
Bidding for major events 59  
Bites and stings 190  
Blood borne pathogens 192  
  Facility/Equipment Sanitation 193  
  Personnel Protection 192  
  Exposure plan 193  
  Protocols-handling/exposure 193  
Body awareness 118  
Body composition 130  
Body leverage 108  
Bubbles 67  
Breach of Duty 4, 11

## C

Cardiorespiratory endurance 130  
Care 144  
Cataracts/eye damage 196  
Cause 5  
Centerlines 57  
Cervical Collar 167  
  Sizing a cervical collar 167  
  Applying a cervical collar 168  
Cervical spine 124  
Clearing the pool 44  
Coach's role in EMS system 38, 144  
Communication 106  
Comparative negligence 6  
Competition rules 127  
Competitive diving EAP 39  
Competitive diving equipment 61  
  Springboards-Duraflex 62  
Competitive diving facilities 53  
  Facility dimensions 54  
Complex skills 100  
Compliance 57  
  State regulating agencies 57  
  Compliance inspection 57

Consent for treatment of minor 19, 127  
Contents of first aid kits 41  
Contributory negligence 5  
Cooling outdoor platform surfaces 57  
Core skills 100  
Covering the platform facing 60  
Current competencies 10

## D

Damages 5  
Deciding to transport injured diver 145  
Define roles-lifeguards 38  
Define roles-assistants 38  
Delivery 50  
Dental injuries 190  
Design 57, 67, 70  
  Above ground sparging system 70  
  In ground sparging system 67  
  Facility design matrix 57  
Development stages 118  
Dimension C-platform location 57  
Disabilities 128  
Disease 73  
  Spa and hot tubs 73  
Dislocations 188  
Dive/skill assessment chart 34  
Diver information file 39  
Diving coach/staff job description 32  
Diving envelope 54  
Documentation 15  
  Accident report 24  
  Addenda 18  
  Authorization to consent to medical  
    treatment of a minor 23  
Diving coach/staff job description 32  
  Emergency information 23  
  Equipment inspection  
    checklist 29, 30  
  Facility inspection checklist 28  
  Incident report 25  
  Injury report/physicians report 22  
  Preparticipation evaluation 19  
  Preparticipation medical  
    history 19, 20  
  Preparticipation examination 21  
  Repair/maintenance request 31  
  Pool Safety Guidelines  
    for Competitive divers 33  
  U.S. Diving Injury Surveillance 18

- Warn of inherent risk 16
- Keep Records 16
- Drowning victims 147
  - Distressed swimmer 147
  - Active drowning 147
  - Passive drowning 148
- Dry board/platform 81
- Dryland training 75
  - Gymnastic mats 75
- Duraflex 62
- Durafirm stands 63
  - Bolts, fasteners 63
- Duraflex fulcrum contacts 63
- Duty 4, 11
- Duties 11
  - of the meet director 11
  - of the event referee 11
  - of the judges 11

**E**

- Elbow 125
- Elements of Plaintiff's Tort Case4
  - Duty 4
  - Breach of Duty 4
  - Cause 5
  - Damages 5
- Emergency action plan 38
  - Accident/injury 39
  - Facility EAP 44
  - Competitive diving program 45
  - Post injury follow up 41
- Emergency first aid 173
  - Rescue breathing and CPR 173
  - Modified jaw thrust technique 173
  - Victim regurgitation 174
- Emergency information 23
- Emergency response 141, 14
  - Assessing injury severity 145
  - Care 144
  - Coach role in EMS system 44,144
  - Deciding transport injured diver 145
  - Guidelines-transport 145
  - Plan for first aid care 145
  - Treatment 144
- Endurance 129, 130
  - cardiorespiratory 130
  - muscular 129
- Energy production 128
- Equipment 12
  - Above ground sparging systems 70
  - Backboard 166
  - Cervical Collar 167
  - Competitive springboards 62
  - Dry board/platform 81
  - In ground sparging systems 67
  - Gymnastic mats 75
  - Overhead mounted pulley rig 82

- Portable landing pits 79
- Rescue equipment 148
- Restricting unauthorized access 96
- Spa and hot tubs 72
- Spotting belts 89
- Trampoline 81
- Wet board 81
- Equipment inspection checklist 29, 30
- Equipment regulations 56
  - Springboards 56
  - Platforms 56, 96
  - Overhang 56
  - Safety rails 56
  - Platform stairs 57
- Evaluation 50
- Eyes/vision 128
- Eye injuries 189

**F**

- Facilities 12
  - Shared use 96
- Facility emergency action plan 38
- Facility dimensions 54
  - Compliance 57
  - Design matrix 57
  - Diving envelope 54
  - FINA dimensions 55
  - How to use dimensions 54
  - Lighting 56
  - Platforms 56
  - Stacked platforms 56
  - Installing platform covering 59
  - Installing platform surface 59
  - Plummet 54
- Facility design 59
  - Design matrix 57
  - Bidding for major events 59
  - Staging 59
- Facility inspection checklist 28
- Fall recovery 112
- Fecal contamination 194
- FINA dimensions 55
- First aid 177
  - Life threatening emergencies 178
    - Breathing emergencies 178
    - Concussion 180
    - Facial injuries 181
    - Fractured skull 181
    - Head, neck, back injuries 180
    - Heat exhaustion 184
    - Heat stroke 184
    - Internal bleeding 182
    - Laryngospasm 180
    - Seizures in water 183
    - Shock 178
    - Special situations-water 179
    - Spinal injuries 182

- Non life threatening 185
  - Bites and stings 190
  - Soft tissue 185
  - Closed wound 185
  - Dental injuries 190
  - Heat and Cold Emergencies 191
    - Heat cramps 191
    - Hypothermia 191
    - Sun burn 191
  - Impact injuries 189
    - Eye injuries 189
    - Eye injuries 189
    - Nosebleed 189
    - Ruptured eardrum 189
    - Genital injuries 190
- Musculoskeletal 186
  - Causes 187
  - Conservative treatment 187
  - Dislocations 188
  - Fractures 188
  - General care 188
  - Muscle spasms 187
  - Strains 186
  - Sprains 186
  - Open wound 185
    - Diving specific concerns 186
    - Stitches 186
    - Scalping 186
    - Sinus squeeze 190
    - Sudden illness 191
- First aid kits 47
- Fitness components 128
- Flexibility 133
  - Ballistic stretching 134
  - Guidelines 134
  - PNF stretching 134
  - Static stretching 133
- Fracture healing 139, 188

**G**

- Genital injuries 190
- Group scoring chart 33
- Gymnastic mats 75
  - Caution 77
  - Characteristics 76
  - Dryland training 75
  - Features 77
  - Intended use 78
  - Selection 75
  - Type 77
- Guidelines 31
  - Flexibility 134
  - Overhead belt spotting 110
  - Platform competitive entry 116
  - Plyometric training 132
  - Portable landing pit 80
  - Skill progression usage 101

Transporting injured athletes 146  
Warm up 131

## H

Handbelt 104  
Hand-over-hand pattern 108  
Hand spotting 103  
    Hands-on 103  
    Hands-off 103  
    Landmarks 104  
Head orientation  
    Take-off 119  
    Flight 120  
    Comeout 120  
Health 73  
    Blood borne pathogens 192  
    Fecal contamination 194  
    Overexposure to sun 195  
        Actinic keratoses 196  
        Cataracts/eye damage 196  
        Immune suppression 196  
        Melanoma 195  
        Non-melanoma skin cancers 195  
            Basal cell carcinomas 195  
            Squamous cell carcinomas 196  
        Photoaging 196  
        Sun protection 196  
        UV Index 196  
    Spas and hot tubs 73  
    HIV Virus 198  
Heat and Cold Emergencies 191  
    Heat cramps 191  
    Hypothermia 191  
    Sun burn 191  
Heavy rain/hail 44  
Historical perspective  
    diving board 62  
HIV Virus 198  
    Disinfection-surface/equipment 200  
    Precautions against risk 198  
    Special precautions-sport 199  
Hospital follow up 42

## I

Immune suppression 196  
Impaired function 128  
Implementation documentation 17  
Incident report 25, 41  
Inclement weather conditions 43  
    Weather signs 43  
    Clearing the pool 50  
    Heavy rain/hail 50  
    Procedures for clearing pool 50  
    Tornadoes/high winds 51  
Increased body temperature 130  
Inform the chain of command 42  
Inform relatives 42

In ground sparging system 67  
    Design factors 67  
    Effectiveness 67  
    Limitations 67  
    Maintenance 67  
    Mechanism 67  
    Purpose 67  
Injury management 137  
    Criteria for full recovery 139  
    Fracture healing 139  
    Initial management 125  
    Pain-spasm cycle 137  
    Psychological responses-trauma 139  
    Wound healing 137  
Injury control 126  
    Body alignment 126  
    Conditioning 126  
    Preventative taping/bracing 126  
    Rehabilitation 126  
    Skill progression 126  
Injury mechanisms 124  
Injury report/attending  
    physicians 22, 125  
Injury Surveillance 18  
Insurance 16, 70, 86  
Installation 59, 63, 66, 76  
    Diving boards 63, 66  
    Gymnastic mats 76  
    Platform covering 59, 60  
    Platform surface 59, 60

## J, K

Know diver's skills and limitations 10  
Keep records 10, 16  
    Attendance 16  
    Insurance 16  
    Transportation 16  
    Performer readiness 17  
    Proper planning 10, 17  
    Proper equipment 10, 17  
    Supervision 10, 17  
    Proper Instruction 10  
    Proper First aid 10  
    Maintain current competencies 17

## L

Ladders 57  
Landing 111  
Landing technique drills 111  
Lead up skills 100  
Lesson plan 27, 49  
    Modifications 51  
Lighting 56  
Lower extremities 125  
Lumbar spine 124  
    Rounded back 131

## M

Maintain current competencies 17  
Maintenance of 63  
    Above ground sparging systems 70  
    Duraflex diving boards 63  
    Duraflex fulcrum contacts 63  
    Durafirm stands 63  
    Gymnastic mats 76  
    In ground sparging system 67  
    Spotting belts 90  
Manufacturer's install instructions 66  
Manufacturer's specifications 65  
Maximum slope 56  
Melanoma 195  
Modification lesson plans 51  
Muscle spasms 187  
Muscular endurance 129  
Musculoskeletal injuries 186  
    Causes 187  
    Conservative treatment 187  
    Dislocations 188  
    Dislocations 188  
    General care 188  
    Dislocations 188  
    Muscle spasms 187  
    Sprains 186  
    Sprains 186

## N

Non-melanoma skin cancers 195  
Non-swimming assists 149  
    Reaching and extension assist 149  
    Throwing assist 150  
Nose bleed 189

## O

Operating procedures  
    Above ground sparging system 70  
    In ground sparging system 68  
    Predetermined start procedure 68  
    Safety precautions 68  
Operational safety guidelines  
    sparging systems 69  
Orthopedic care 124  
    Abrasions 125  
    Cervical spine 124  
    Elbow 125  
    Initial injury management 125  
    Injury mechanisms 124  
    Lower extremities 125  
    Lumbar spine 124  
    Shoulder 124  
    Wrist and hand 125  
Overhang 56  
Overhead mounted pulley rig 82  
    Care and maintenance 85  
    Ceiling clamps and pulleys 82

- Overhead clearance 83
- Placement 83
- Positioning 82
- Rope 82
- Overhead mounted belt spotting 108
- Body leverage 108
- Hand-over-hand pattern 108
- Learning to control slack 108
- Precautions 110
- Rope wrap techniques 108
- Spotting progressions 101
- Tipping 109

## P

- Pain-spasm cycle 137
- Participant readiness 11
- Performer readiness 17, 123
- Photoaging 196
- Physical environment 10, 17
- Physical Readiness 127
  - Assessments 130
  - Body composition 129
  - Cardiorespiratory endurance 129
  - Competition rules 127
  - Consent for treatment of minor 23
  - Energy production 128
  - Eyes/vision 127
  - Flexibility 129
  - Fitness components 128
  - Disabilities/impaired function 127
  - Muscular endurance 129
  - Power 128
  - Preparticipation screening 127
  - Shared responsibility 127
  - Skill 32, 33, 34, 35, 129
  - Skill Progression 127
  - Strength 128
  - Swimming competency assess 128
  - Training principles 131
  - Waiver/release of liability 7, 9, 128
  - Warm up 130
- Planning documentation 17
- Platform 129
- Platforms 56, 57
  - Body alignment 10-m entries 115
  - Centerlines 57
  - Covering the platform
    - facing 59, 60
  - Installing platform surface 59,60
  - Installing the covering 59, 60
  - Stacked 96
  - Ten meter platform entry 115
- Plummet 54
- Plyometric training 133
  - Guidelines 133
- Policies and procedures manual 40
- Pool Safety Guidelines

- for Competitive Divers 33
- Portable landing pits 79
  - Air flow 79
  - Dimensions 79
  - Location 79
  - Materials 79
  - Requirements 79
  - Shock absorption 79
  - Test for fatigue 80
- Post injury follow up 47
  - Inform the chain of command 42
  - Inform relatives 42
  - Hospital follow up 42
  - Posttraumatic stress 42
- Post skill training 48
- Posttraumatic stress 42
- Power 129
  - Springboard 129
  - Platform 129
- Practice plans 50
- Proper planning 43
  - Define roles-assistants 44
  - Diver information file 45
  - Heavy rain/hail 50
  - Inclement weather conditions 50
  - Modification lesson plans 51
  - Policies and procedures manual 46
  - Plan for first aid care 145
  - Practice plans 50
    - Tornadoes/high winds 51
    - Weather signs 50
  - Procedures for clearing pool 50
  - Back up plans 51
  - Modification lesson plans 51
- Preparticipation evaluation 19, 39, 127
- Preparticipation medical
  - history 19, 20, 127
- Preparticipation examination 21
- Procedures for clearing pool 44
- Progressive development stages 118
- Proper equipment 10, 17
- Proper First aid 10
- Proper instruction 10, 99
  - Body awareness 118
  - Using skill progressions 100
  - Landing and entry 111
  - Safety spotting 103
  - Spatial orientation 118
  - Overhead mounted belt spotting 108
- Proper planning 10, 17
  - Back up plans 51
  - Coach's role 44
  - Diver information file 45
  - Define roles-lifeguards 44
  - Proximate cause 5
- Psychological responses-trauma 139

## Q, R

- Reaching and extension assist 149
- Readiness 127
- Recovery criteria 28
- Recovery from off-balance 111
- Recurrent distressing
  - emotions/memories 43
- Recurrent dreams 43
- Removal from water 153,
  - Conscious victim-surface 153
  - Lower extremity 156, 158
  - Upper extremity 155, 157
- Repair/maintenance request 31
- Rescue equipment 148
  - Reach pole 148
  - Rescue tube 148
  - Shepherd's crook 148
- Rescue techniques-injured divers 147
  - Approaching victim 141
  - Identifying drowning victims 147
  - Non-swimming assists 149
  - Removal from water 153
  - Rescue equipment 148
  - Swimming assists 150
  - Unconscious victim 152
    - surface 152
    - bottom/underwater 152
- Return to activity authorization 22,125
- Return to diving 125
- Resistance training 131
  - Basic resistance training 11
  - Guidelines 132
  - Youth resistance training 132
- Risk of collision 96
  - Shared use 96
  - Stacked platforms 96
- Ruptured eardrum 189

## S

- Safety competencies documentation 18
- Safe landing positions 112, 113
- Safety precautions-sparging system 68
- Safety consideration
  - sparging system 68
- Safety rails 56
- Safety spotting 103
  - Communication 106
  - Knowledge of limitations 105
  - Matching with task difficulty 105
  - Methods 103
  - Purposes 103
  - Prerequisites 105
- Safety spotting belts 89
- Safe Physical Environment 10
- Scalping 186
- Sensory systems 118
- Session plan 45, 46, 47

- Session Planner 26
  - Shared responsibility 127
  - Shoulder 124
  - Sinus Squeeze 190
  - Skill 130
  - Skill mastery monitoring 51
  - Skill progression 67, 100, 127
    - Competition rules 127
    - Complex skills 100
    - Core skills 100
    - Developing a progression 101
    - Goals and progress 100
    - Lead up skills 100
    - Use of 100, 101
    - Use of bubbles 67
    - Reinforcement 104
    - Simple to complex 100
  - Spa and hot tubs 73
  - Sparging system 67
    - Above ground 70
    - In ground 67
    - Insurance 70
    - Operating procedures 68
    - Operational safety guidelines 69
    - Predetermined start procedure 68
    - Safety precautions 68, 70
  - Spatial orientation 104, 118
  - Sensory systems 118
  - Progressive development stages 118
  - Visual spotting 119
    - Head orientation at take-off 119
    - Head orientation in flight 120
    - Head orientation at comeout 120
  - Spinal cord injury 114
    - Cervical spine 124
    - Injury control strategies 114
    - Lumbar spine 124
    - Mechanism 114
    - Shallow water profile 114
  - Spinal injury management 160
    - Approaching victim 163
    - Backboarding 166
      - Deep water 169, 170
      - Procedures 169
      - Securing victim 171
      - Shallow water 174
    - Cervical Collar
    - Contacting a spinal injury victim 162
    - Emergency first aid 173
      - Rescue breathing and CPR 173
      - Modified jaw thrust 173
      - Victim regurgitation 174
    - Head splint rescue 163
    - Head splint turn over 163
    - Injuries on deck/water 162
    - Recognizing spinal injuries 160
    - Shallow water backboarding 174
    - Signs of spinal injury 162
    - Understanding the spine 160
    - Victim in deep water 165
    - Victim-supine (face up) 163
  - Spotting belts 89
    - Uniaxial 89
    - Biaxial 89
    - Swivel clips 89
  - Spotting methods 103
    - Hand spotting 103
      - Hands-on 103
      - Hands-off 103
    - Landmarks 104
    - Overhead mounted belt 104
    - Landings 104
    - Entries 104
  - Sprains 186, 187
  - Springboard 129
  - Springboards 56, 62
    - Springboard ladders 57
    - Glide Paths 57
    - Board, fulcrum and stand 63
    - Competitive governing body guidelines 63
    - Duraflex 62
    - Durafirm stands 63
    - Duraflex fulcrum contacts 63
    - Historical perspective 62
    - Installation 63, 66
    - Maintenance of nonskid surface 63
    - Safety features 62
  - Squamous cell carcinomas 196
  - Stacked platforms 56
  - Staging 59
  - State regulating agencies 57
  - Statutory protection 12
    - for volunteer officials 12
  - Stitches 186
  - Strains 186, 187
  - Strength 129
  - Stride jump 150
  - Sudden illness 191
  - Sun protection 196
  - Supervision 10, 17, 91
    - Blend 96
    - General 92
    - Matching task difficulty 94
    - Practice-non-conforming pools 96
    - Risk related 92
    - Risk of collision 96
    - Shared responsibilities 92
    - Specific 92
    - Strategies 94
    - Traffic control 95
  - Supervisor 94
  - Swimming assists 150
    - Stride jump 150
  - Waveless entry 151
  - Swimming competency assess 128
- T**
- Tornadoes or high winds 44
  - Torts 4
    - Negligence 4
  - Tort Defenses 5
    - Contributory negligence 5
    - Comparative negligence 6
    - Assumption of risk 6
  - Traffic control protocol 95
    - Check and balances 95
    - Clearance awareness 95
    - Distance awareness 95
    - Take-off initiation criteria 95
    - Temporal awareness 95
  - Training principles 132
  - Training stations 85
  - Trampoline 81
    - Safety record 81
    - Overhead clearance 81
    - Simulation of dives 81
  - Transportation 17
  - Treatment 144
- U**
- Unconscious victim 152
    - surface 152
    - bottom/underwater 152
  - U.S. Diving Amateur Athletic Waiver/Release of Liability 9
  - U.S. Diving Injury Surveillance 23
  - UV Index 196
- V**
- Vision 128
  - Visual perception 56
    - Lighting 56
  - Visual spotting 119
- W**
- Waiver/release of liability 7, 9, 128
  - Warm up 48, 130
    - Guidelines 131
    - Increased body temperatures 130
    - Sample Warmup 130
  - Warn of inherent risk 16
  - Water entry 114
    - Body alignment 10-m entries 116
    - Shallow water 114
    - SCI control strategies 114
    - Spinal cord injury mechanism 114
    - 10-meter platform entry 115
    - Water depth 114
  - Waveless entry 151

Weather signs 43  
Clearing the pool 44  
Wet board 81

#### Wounds

Abrasions 185  
Avulsion 185  
Closed wound 185  
    First aid care 185  
Open wound 185  
    Diving specific concerns 186  
    First aid 186  
    Stitches 186  
    Scalping 186  
Lacerations 185  
Wound healing 137  
Wrist and hand 125

#### **X, Y, Z**

Youth resistance training 132





The NCAA Committee on Competitive Safeguards and Medical Aspects of Sports commends United States Diving, Inc. on its efforts toward enhancing safety in diving through developing the *U.S. Diving Safety Training Manual* (Second Edition) to use as an educational tool in coaches' safety training programs.

**Randall W. Dick**  
**Senior Director of Sports Sciences**  
**National Collegiate Athletic Association**

The *U.S. Diving Safety Training Manual* is a comprehensive guide which will have value to coaches who instruct young people in the sport of diving.

**Tim Flannery**  
**Assistant Director**  
**National Federation of State High School Associations**

Sports safety is a primary concern for the certified athletic trainer. The National Athletic Trainers' Association is in favor of any effort to improve the care and safety of our athletes, and commends U. S. Diving for its initiative in this area.

**National Athletic Trainers' Association, Inc.**  
**NATA Board of Directors**

The new *U.S. Diving Safety Training Manual* -2nd Edition is a comprehensive manual that should prove to be a valuable resource and beneficial to all interested in learning springboard diving and enhancing safe diving practices.

**Laura J. Slane**  
**Associate Director-Aquatics**  
**Membership Program Development**  
**YMCA of USA**

The *U. S. Diving Safety Manual* was simply superlative, and the latest *Safety Training* edition is even better. It is the best treatise of safety ever written for teaching or coaching the sport of diving. Congratulations to United States Diving on an unprecedented collaborative success. This manual has been placed in the International Swimming Hall of Fame, Henning Library and FINA libraries as the consummate reference text for diving.

**Samuel James Freas, Ed.D.**  
**President/CEO**  
**International Swimming Hall of Fame**

The Professional Diving Coaches Association recommends the *U.S. Diving Safety Training Manual* for every coach's library as a resource tool for professional development. The PDCA greatly appreciates the efforts of U.S. Diving in developing and publishing this much needed manual.

**Keith Russell**  
**President**  
**Professional Diving Coaches Association**